

INTRODUCTION

THEORY OF ERROR ANALYSIS

AND THE NATURE OF EXPERIMENTATION

Students often complain that physics experiments simply don't work, at least as far as they are concerned. They consider textbook results as sacred because they have supposedly been determined by scientists. Such misconception can be avoided by careful understanding of the nature of experimental physics with sufficient insight into the theory of errors.

But first, few rules:

- The result of an experiment must be written as the example shows for a recent determination of the velocity of light:

$$C = (2.997923 \pm 0.000008) \times 10^{10} \text{ cm s}^{-1}$$

The first number, 2.997923×10^{10} gives the best estimate of the true value of the velocity of light. 0.000008×10^{10} reflects the reliability with which that value has been determined. This is an example of a computed experimental value, a type that we shall come to later.

- When the problem is as simple as doing a single measurement with a certain device, like measuring a length with a regular rule, one must be careful with the last significant figure that he writes. This may be a fraction of the smallest division on the ruler, or scale depending on the physical situation.
- When doing many experiments, one often discards unreliable data (there exists rules for doing that) and takes the average of the rest. And since results of experiments of different types have different uncertainties, they must be given different weights. Above all there are the errors of human judgment. The results of experiments are, in the final analysis, matters of opinion although rules exist. The word error used here does not mean mistake. Some people prefer uncertainty or discrepancy, but we shall stick to the general trend in the literature of using error, keeping in mind that it does not mean that the result is wrong.
- Care should be taken here not to consider textbook values as true or exact. There does not exist such a thing as a true or exact value in experimental science.
- One way of classifying errors is to sort them into systematic and random errors. When repeated measurements of a given value don't agree exactly, deviations from the "best estimate of the true value" are as a result different. This is the case of random errors. When, on the other hand, individual values differ by the same constant, they are systematic.
- Examples of systematic errors are :

1. Errors of instrument calibration.
 2. Errors like the ones caused by the habit of always looking from a slanted perspective onto a galvanometer needle.
 3. Experimental conditions might be set up to introduce a systematic error.
 4. Imperfect techniques, like allowing fluid to leak out of a vessel in a fluid flow experiment at a constant rate.
- Examples of random errors are :
 1. Errors of judgment like the case when one has to estimate a smallest division in a given instrument.
 2. Small disturbances like mechanical fluctuations in an electrical instrument.
 3. Definition of the measured quantity is often difficult. A simple example is a measurement of the length of a table.
 - Another type of error is totally *illegitimate* and is called by that name. Examples of this are the *blunders*. These are outright mistakes in reading, adjusting or calculating. Errors of *computation* like using an instrument with less significance than sufficient is of this type. However, when the effect of disturbances becomes far beyond random discrepancies, it is called *chaotic*. If it gives a totally illogical result it is called a *wild error*. Errors of this type which are surely illegitimate can't be incorporated in the results and are to be corrected for right from the start.
 - Errors can also be classified according to whether they are *determinate* or *indeterminate*. Determinate errors are those which can be evaluated by some logical procedure. They include random errors that can be calculated using the techniques mentioned below, and specific types of systematic errors that can be evaluated.

Precision, Accuracy and Significant Figures:

An experiment having small random errors is said to have high *precision*. Two devices may also differ in their precision. A micrometer, for example, is more precise than a millimeter ruler.

An experiment that has, on the other hand, a small systematic error is said to have high *accuracy*. Devices also differ in accuracy. Two micrometers have the same *precision* but if one of them is broken, it will introduce a certain systematic error, and is less accurate than the other.

The number of significant digits that one displays measurement in a certain or result must reflect its precision. It is, therefore, in order here to present the rules for treating significant figures:

- The leftmost non-zero digit is the most significant digit.
- If there is no decimal point, then the right most non-zero digit is the least significant digit.

- If there is a decimal point, then the rightmost digit is the least significant digit, even if it is zero.
- All digits between the least and most significant digits are counted as significant digits.

Example:

1,234; 123,400, 1,001; 1,000; 10.10; 0.0001010; 100.0 are numbers that have four significant figures. But 1010 has three significant figures. If it is to have four significant figures it must be written as 1,010. or 1.010×10^3 .

When performing a calculation, the result has the significance of that number involved which has the least significance.

Single Measurement Experiments

Suppose that one can repeat a certain experiment and he gets different values for a certain physical measurement. Which one of those values must be taken as the true value?

As mentioned before, one can never arrive at the true or exact value. To do so he must repeat the experiment an infinite number of times. For a finite number of measurements N , one can say that he obtains a best estimate of the true value. This is taken to be the arithmetic average of the set of measurements:

$$\bar{x} = \frac{\sum_{i=1}^N x_i}{N}$$

This is taken as the best value because the sum of the squares of the deviation of individual measurements about this average is a minimum:

$$\begin{aligned} \bar{x} &= \sum_{i=1}^N (x_i - \bar{x})^2 = \sum_{i=1}^N (x_i^2 + \bar{x}^2 - 2\bar{x}x_i) \\ \bar{x} &= \sum_{i=1}^N x_i^2 + N\bar{x}^2 - 2\bar{x} \sum_{i=1}^N x_i \end{aligned}$$

To find the value of \bar{x} that makes \bar{x} a minimum we take the deviation and equate to zero:

$$\frac{d\bar{x}}{d\bar{x}} = 2N\bar{x} - 2 \sum_{i=1}^N x_i = 0$$

This gives $\bar{x} = \frac{\sum x_i}{N}$ as claimed.

The average value of these square deviations is also of importance:

$$s' = \sqrt{\frac{\sum_{i=1}^N (x_i - \bar{x})^2}{N}}$$

It is called the standard deviation or the root mean square (rms) deviation.

When $N = 1$, $s' = 0$ and, thus, is of no help. We, therefore, define:

$$s = \sigma_{N-1} = \sqrt{\frac{\sum_{i=1}^N (x_i - \bar{x})^2}{N-1}}$$

For large values of N , s is only slightly different from s' . Using s , nevertheless, does not allow one to do statistics with one measurement. s is called the sample standard deviation and its physical significance is that it gives the uncertainty in the individual measurements about their average. The uncertainty in the average itself shrinks with increasing number of measurements. It is called the standard deviation of the mean σ_M and is defined as:

$$(1) \quad \sigma_M = \frac{\sigma_{N-1}}{\sqrt{N}} = \frac{s}{\sqrt{N}}$$

A single measurement experiment is best analyzed by drawing a frequency histogram. (see 111 manual).

Propagation of errors

Not all physical quantities are directly measured. Some of them, like the above example of the speed of light, are computed. Errors are propagated in the sense that any discrepancy in the measured values will appear as a discrepancy in the computed one.

The general relation is as follows:

let f be computed from the measured values x_1, x_2, \dots, x_N or, $f = f(x_1, x_2, \dots, x_N)$. From calculus one has:

$$\Delta f = \frac{\partial f}{\partial x_1} \Delta x_1 + \frac{\partial f}{\partial x_2} \Delta x_2 + \dots + \frac{\partial f}{\partial x_N} \Delta x_N$$

Since errors are vectorial in nature, i.e. a discrepancy in one quantity might cause an effect which is opposite to the one caused by another, one takes an average direction and Δf is defined as:

$$\Delta f = \sqrt{\sum_{i=1}^N \left(\frac{\partial f}{\partial x_i}\right)^2 (\Delta x_i)^2}$$

Example:

The volume of a parallel piped is measured by measuring x , y , and z its three dimensions x , y , and z :

$$V=xyz$$

$$\frac{\partial V}{\partial x} = yz, \quad \frac{\partial V}{\partial y} = xz, \quad \frac{\partial V}{\partial z} = xy,$$

$$\Rightarrow \Delta V = \sqrt{(yz)^2(\Delta x)^2 + (xz)^2(\Delta y)^2 + (xy)^2(\Delta z)^2}$$

or,

$$\frac{\Delta V}{V} = \sqrt{\left(\frac{\Delta x}{x}\right)^2 + \left(\frac{\Delta y}{y}\right)^2 + \left(\frac{\Delta z}{z}\right)^2}$$

Equation (2) is a general relationship that holds for all functions, some of the more important special cases are summarized below:

- If $f = axyz$, or $f = ax^a y^a z^a$, “a” being a constant, then:

$$\frac{\Delta f}{f} = \sqrt{\left(\frac{\Delta x}{x}\right)^2 + \left(\frac{\Delta y}{y}\right)^2 + \left(\frac{\Delta z}{z}\right)^2}$$

- If $f = ax^e y^m z^n$, then:

$$\frac{\Delta f}{f} = \sqrt{e^2 \left(\frac{\Delta x}{x}\right)^2 + m^2 \left(\frac{\Delta y}{y}\right)^2 + n^2 \left(\frac{\Delta z}{z}\right)^2}$$

- If $f = ax \pm by \pm cz$, then:

$$\frac{\Delta f}{f} = \sqrt{a^2(\Delta x)^2 + b^2(\Delta y)^2 + c^2(\Delta z)^2}$$

References:

Physics 111 Laboratory Manual.

Beers, Y. Introduction to the Theory of Error. Addison Wesley, 1957.

Bevington, P. Data Reduction and Error Analysis for the Physical Sciences. McGrawHill, 1969.

Roberts, D. "Errors Discrepancies and the Nature of Physics", Physics Teacher, March 1983.

GENERAL REVIEW I

DIRECT CURRENT CIRCUITS

Introductory Concepts

Current (I):

The motion of electric charges constitutes an electric current. Specifically, the current is the time rate at which a charge (Q) passes through a given cross-sectional area of a conductor, so that:

$$(1) \quad I = \frac{dQ}{dt}$$

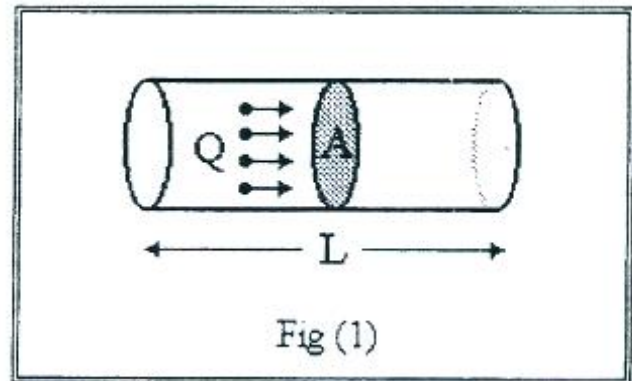

Electric current is measured in Coulombs (C) per second; this unit is termed the Ampere (A).

Voltage (V):

The work required to move a unit charge from one point to another is called the electric potential difference (technically referred to as the voltage difference "V") between the two points. Symbolically,

$$(2) \quad V = \frac{W}{Q} ,$$

where W stands for work and Q for charge. The unit of voltage is the volt defined by:

$$1\text{volt}(1V) = \frac{1J}{1C}$$

Resistance(R)

The resistance that each free electron encounters as a result of multiple collisions when moving through a conductor depends upon a material property called resistivity (ρ) in addition to the shape of the conductor, so that the resistance(R) of a wire L meters long and A squared meters in cross-sectional area (see fig (1)) is given by:

$$R = \rho \frac{L}{A}$$

The unit of resistance is the Ohm (Ω).

Question: Find the units of ρ .

Ohm's Law:

In order to maintain a large current in a conductor, more energy, hence a greater potential difference is required than in the case of a small current in the same conductor, hence, the potential difference is directly proportional to the current. The constant of proportionality is just the resistance (R) of the conductor, or

$$(3) \quad V = RI$$

This equation is known as *Ohm's law*.

Joules Law:

The kinetic energy of the electrons in a conductor, which results from acceleration by the electric field, is dissipated in inelastic collisions within the conductor. As a result, the conductor heats up. In other words, the temperature of a conductor carrying a current must increase, at least slightly, and it is apparent that electric power is expended in sustaining a current through the conductor. The power (P) that must be supplied to the conductor to sustain the current is given by:

$$P = \frac{dW}{dt}$$

Using equation (2) we get,

$$P = V \frac{dQ}{dt} = VI$$

Now, substituting for V using Ohm's law, we get,

$$(4) \quad P = I^2R$$

This equation is known as *Joule's Law*. The unit of power is the Watt (J/s).

Circuit Elements:

I) Sources

According to Joule's law, electric energy is dissipated in any conductor when it carries a current. Therefore, in order to maintain the current in any circuit, a source of electrical energy is required. Common sources of electrical power are ordinary batteries, voltage power supplies, and current sources.

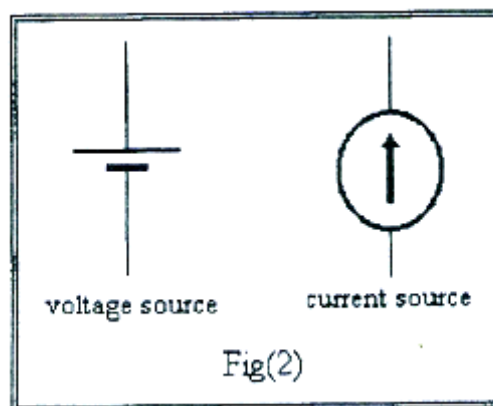

An ideal voltage source (a battery or a power supply) can maintain a constant voltage difference between its terminals regardless of the value of the load resistance in the circuit. Therefore, it offers no

resistance to the current passing through it and is characterized by a zero internal resistance. On the other hand, an ideal current source can supply a constant current regardless of the value of the load resistance in its circuit. An ideal current source is characterized by an infinite internal resistance. However, ideal sources do not exist in reality; therefore, there are limits on the voltage and the current that both voltage and current sources can provide to circuits.

2) Circuit components

Electrical circuit's components are the consumers of the power generated by the power supplies. Resistors are circuit elements that respond linearly to applied voltage differences across them. Therefore, resistors are called linear circuit elements. Linear circuit elements obey Ohm's law ($V = RI$) and are said to have linear I-V characteristics. Diodes and light bulbs are examples of non-linear circuit elements. Non-linear circuit elements do not obey Ohm's law and are said to have non-linear I-V characteristics.

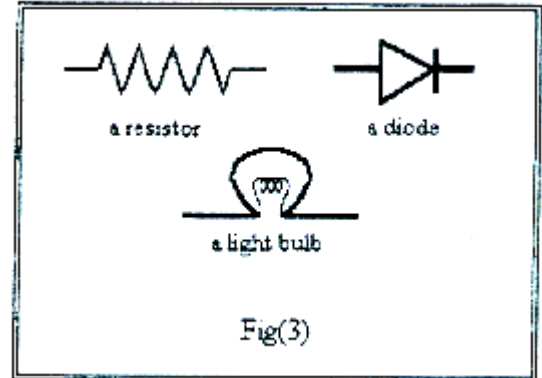

3) Connecting wire

In order to connect power supplies and circuit components in a closed electrical circuit, wire made of copper is used. Ideal connectors offer zero resistance to the current passing through them. In reality, however, wires possess a small resistance to the current passing through them.

EXPERIMENT 1

LINEAR AND NON-LINEAR CIRCUIT COMPONENTS

Theory

The relation between the current passing through a circuit component and the voltage difference between its terminals is called the *I-V characteristic* of that component. Components that have straight line I-V characteristics are called *linear components*. The slope of the line that represents the I-V characteristics of a component is the value (1/resistance) of that component (see Fig(1)). Most resistors used in the laboratory are carbon resistors, which are essentially linear.

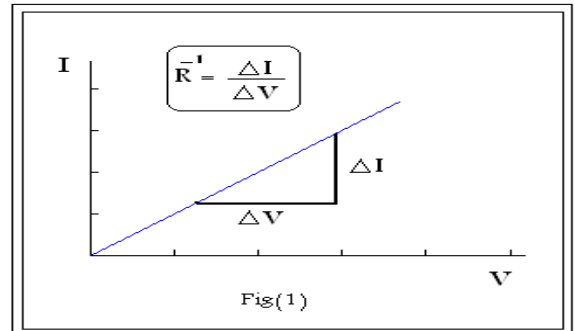

Components that do not possess straight line I-V characteristics are called non-linear components. An example is a diode. A semiconducting diode, for instance, consists of two pieces, a p-type piece of a semiconducting* material and an n-type piece of the same material joined together. Diodes are two terminal components that allow current to pass through in one direction only; almost no current passes through in the other direction (parts of micro-amperes). Therefore, the way the diode is connected to a battery is crucial. When the p-type terminal of the diode is connected to the positive terminal of the battery, it allows current to pass through and the diode is said to be forward-biased. On the other hand, if the n-type terminal of the diode is connected to the positive terminal of the battery, it blocks the current so that a very small current flow through the circuit and the diode is said to be reverse-biased.

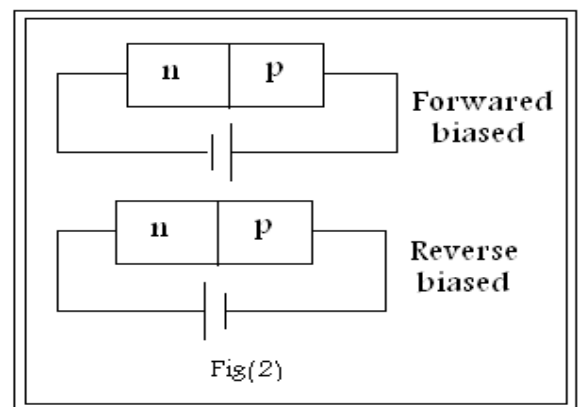

The relation between the current (I) passing through a semiconducting diode and the potential difference (V) between its terminals usually has the following form (see Fig(3))

$$(1) \quad I = I_0 (e^{eV/kT} - 1),$$

where I_0 is called the saturation current, e is the electron charge, V is the applied voltage, k is the Boltzmann constant, and t is the temperature in Kelvin.. Therefore, a semiconducting diode has a variable resistance that depends on the value of the current passing through it.

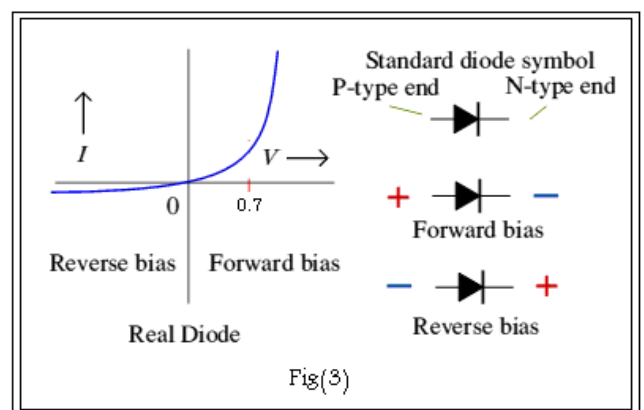

*Consult Serway's " Physics: with modern physics" for an elaborate discussion of semiconductors.

A *light bulb* is another example of a conducting material that possesses non-linear characteristics. The tungsten wire in a bulb converts electrical power to heat energy. Consequently, the wire glows and emits light. The resistivity, and thus the resistance of conducting material, depends on the temperature of that material according to

$$(2) \quad R = R_0 [1 + \alpha(T-T_0)],$$

where R_0 is the resistance at temperature T_0 and α is the temperature coefficient of resistivity. Therefore, since the temperature of the tungsten increases by increasing the current passing through it, one expects the light bulb to have a non-linear I-V characteristic and a resistance that depends on the value of the current.

Apparatus

A DC. voltage source (6 volts), one carbon resistor (200 Ω), two digital multimeters, connecting wire, a decade resistor box, a silicon diode and a light bulb.

Procedure

- Connect the circuit shown in Fig(4).
- Use the resistor as your circuit element. Change the value of R (decade box resistance) and record about eight different values for the current and the corresponding voltage values.
- Repeat part (b) using a forward-biased diode as your circuit component.

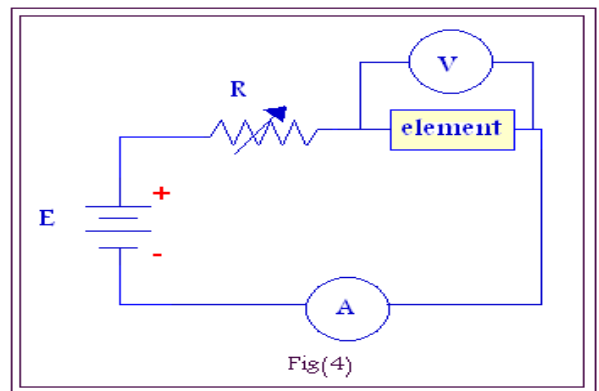

Warning: current passing through the diode should not exceed 30 mA in all measurements,

- Reverse bias your diode and check if it conducts or not. Register the current flowing in this case; this is I_0 in equation (1).
- Repeat part (b) using the light bulb as your circuit component.

Note: a high current (~100 mA) is needed to light the bulb. Watch the brightness. of the bulb to decide on the upper current limit (~300mA). Do not exceed this value during the experiment.

Analysis of results

- Use your data to draw the I-V characteristic curves for the carbon resistor, the diode and the light bulb on a linear graph paper. Decide which component is linear.

- b) Using the I-V characteristic of the carbon resistor, find the value of the resistance and compare it with the value obtained from the color code (see appendix A).
- c) Draw tangent lines at two different points on the curve representing the IV characteristics of the forward-biased diode, and find the value of the resistance at those points.
- d) Repeat part (c) for the tight bulb.

EXPERIMENT 2

SOURCE INTERNAL RESISTANCE, LOADING PROBLEMS AND CIRCUIT IMPEDANCE MATCHING

Theory

A voltage source is characterized by its electromotive force (emf), which is the open circuit voltage difference between its terminals, see Fig(1a), and the maximum value of the current it can deliver to a short circuit. An ideal voltage source connected to a short circuit ($R \sim 0$) should, according to Ohm's law ($I=V/R$), be able to provide an almost infinite current. In real circuits a voltage source connected to a short circuit can neither maintain its (emf) as a voltage difference across its terminals nor can it provide the circuit with unlimited current. Therefore, each real voltage source is assigned an internal resistance (r_{in}). Fig(1b) gives a more realistic representation of a voltage source. It should be obvious that voltage sources with small internal resistances can maintain most of their emf as voltage differences between their terminals and provide circuits with higher current values than would the ones with high internal resistances.

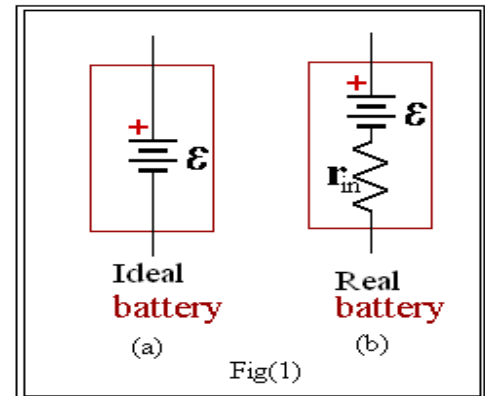

Voltage sources are used to provide useful electrical power to certain circuit components, such as electric motors and light bulbs. Any component which consumes electrical power to produce useful work is called a load and the resistance of such a component is called the load resistance (R_L).

Loading Problem

The current passing through the simple series circuit of Fig(2) is

$$(1) \quad I = \frac{\epsilon}{R_L + r_{in}}$$

So, the voltage difference between the source terminals is

$$(2) \quad V_{R_L} = \frac{\epsilon}{(R_L + r_{in})} R_L$$

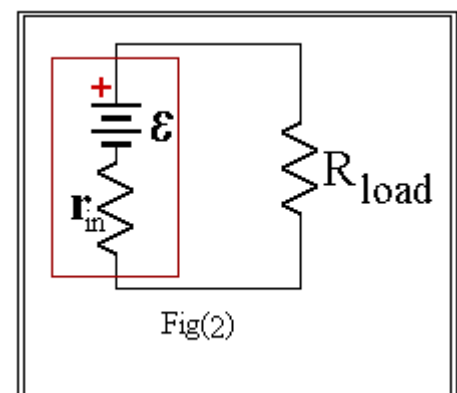

If $R_L \gg r_{in}$ then $V_{R_L} \approx \epsilon$ and the source delivers most of its emf as a voltage difference across its terminals. On the other hand, if R_L is comparable to r_{in} then V_{R_L} is smaller than ϵ , and hence, a considerable amount of power is consumed inside the source and converted to unuseful heat energy. In this case the source is said to be loaded. In practical circuits we want to avoid loading the source, therefore, choosing $R_L \geq 10R_{in}$ is recommended

Impedance Matching (Maximum Power Transfer)

In real circuits, power consumed in the load produces useful work. Therefore, we seek to consume the maximum available power there. In Fig(2) the power consumed in the load resistor is:

$$(3) \quad P = I^2 R_L$$

Therefore,

$$(4) \quad P = \frac{\varepsilon^2 R_L}{(R_L + r_{in})^2}$$

Equation (4) represents the power consumed in the load as a function of the load resistance itself. The function $P(R_L)$ has a maximum value which can be obtained by setting $\frac{dP}{dR_L} = 0$ (see Fig(3)).

This gives

$$R_L = r_{in}$$

as the condition for transferring maximum power to the load resistance. This choice of load resistance is called impedance matching.

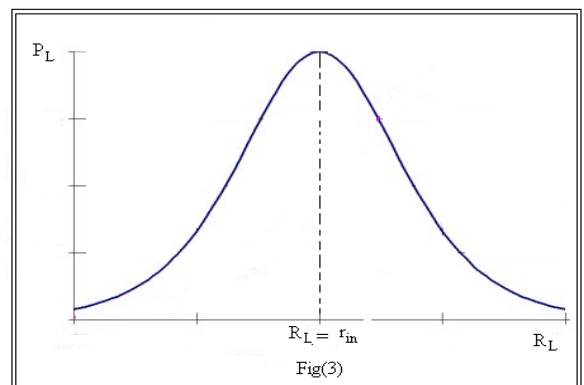

As the internal resistance of voltage sources is usually small (a few Ohms), in practical circuits an additional resistor is connected in series with the source as shown in Fig(4) in order to produce the maximum power transfer condition for large values of R_L . While this additional resistance appears to R_L as an additional internal resistance, it is seen by the source as an additional load resistance. Consequently, this resistance helps in avoiding loading problems and fulfilling the condition of impedance matching for large load values. The only disadvantage is that this additional resistance consumes part of the power delivered to the circuit by the source.

If we apply conservation of energy to the circuit in Fig(4), we get

$$(5) \quad \varepsilon = I r_{in} + I R + I R_L$$

Rearranging, we get

$$(6) \quad \frac{1}{I} = R_L \frac{1}{\varepsilon} + \frac{r_{in} + R}{\varepsilon}$$

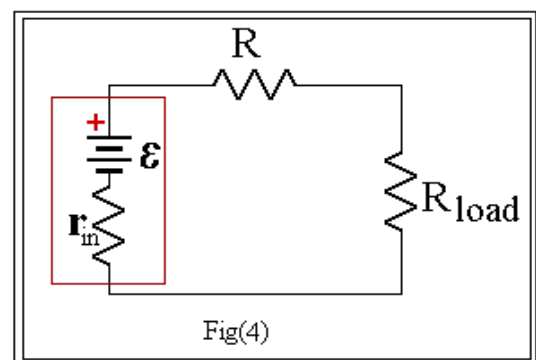

A plot of $\frac{1}{I}$ versus R_L gives a straight line with $\frac{1}{\varepsilon}$ as its slope and $\frac{r_{in} + R}{\varepsilon}$ as its y-intercept.

If we apply the condition of maximum power transfer to the load resistance of the same circuit we get:

$$R_L = R + r_{in}$$

Efficiency

A useful concept to use with power is that of efficiency (η). The efficiency of a component with impedance (resistance) R_L operated from a source with internal resistance r_{in} is the power dissipated in R_L divided by the power dissipated in the circuit. Therefore,

$$(7) \quad \eta(R_L) = \frac{I^2 R_L}{I^2 (R_L + r_{in})}$$

$$\Rightarrow \quad \eta(R_L) = \frac{R_L}{R_L + r_{in}}$$

Apparatus

Voltage source (10volts), 1 K Ω resistor, digital multimeter, resistor decade box.

Procedure

- Connect the circuit shown in Fig(5).
- Change the value of the Load resistance (0-1 M Ω) and record the value of the current each time.

Note: take more data points around the value of R_L which satisfies the maximum power transfer condition.

Analysis of results

- Plot selected values of $\frac{1}{I}$ and R_L on a linear graph paper. Find the value of ε and r_{in} .

Hint: select a range that can be plotted on a single linear graph paper.

- Compute $P(R_L)$ and $\eta(R_L)$ for all values of I . (Use Lotus 123 or equivalent computer aid)
- On a Semi-log graph paper, plot both $P(R_L)$ and $\eta(R_L)$. From the graph; find the value of R_L that satisfies the condition of maximum power transfer.

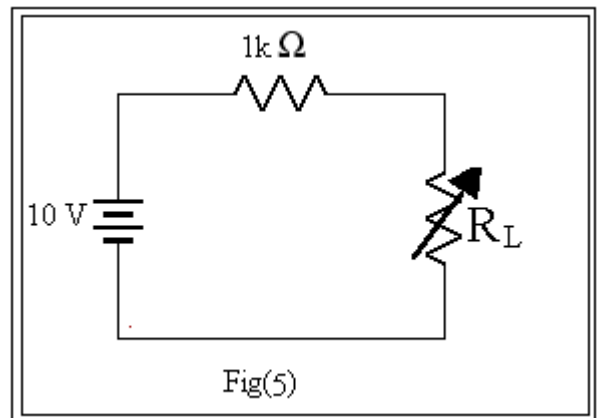

EXPERIMENT 3

NETWORK ANALYSIS I

THE SUPERPOSITION PRINCIPLE AND KIRCHHOFF'S LAW'S

Theory

Electric networks are circuits that include many elements such as resistors, voltage sources and current sources that are connected together in a rather complicated way. In such cases, applying Ohm's law and the simple parallel and series connection rules is of no practical help. Many circuit analysis techniques were developed in order to facilitate analyzing complicated networks. Kirchhoff's laws and the superposition principle are such powerful techniques deduced from nature's most fundamental laws.

Kirchhoff's Laws

- I. *Loop theorem*: This theorem of energy is just the principle of conservation as applied to electric circuits. It states that. ***The algebraic sum of the voltage drops and electromotive forces (emf's) in a closed electric circuit is always zero.*** In other words, the power generated by sources in a closed circuit is totally consumed by the circuit components. Symbolically,

$$\sum_i V_i = 0 \quad ,$$

or,

$$(1) \quad \sum_k \varepsilon_k = \sum_j I_j R_j \quad ,$$

where we have accounted for the opposite signs of voltage drops and emf's.

- II. *Junction theorem*: This theorem is just the principle of conservation of charge applied to electric circuits. It states that. ***The algebraic sum of the currents passing through any circuit junction is always zero.*** Symbolically,

$$(2) \quad \sum_j I_j = 0$$

where the currents entering a junction have opposite signs to those leaving it.

One way of finding the values of the currents passing through the different resistors in a circuit similar to the one shown in Fig(1) proceeds as follows:

- Assign a current of arbitrary direction to each of the resistors in the circuit.
- Apply Kirchhoff's junction theorem to all independent junctions in the circuit.
- Apply Kirchhoff's loop theorem to all independent circuit loops.
- You should be able to produce as many independent equations as there are unknown currents.

Example:

Applying the rules above to the circuit of Fig (1) gives the following:

1- Two junctions exist, but both give the same equation.

$$I_1 - I_2 - I_3 = 0$$

2- Three circuit loops exist, but only two independent could be equations formed (Note that the third large loop will result in an equation that is the sum of the two small loop equations).

$$\varepsilon_1 = I_1 R_1 + I_3 R_3$$

$$\varepsilon_2 = -I_2 R_2 + I_3 R_3$$

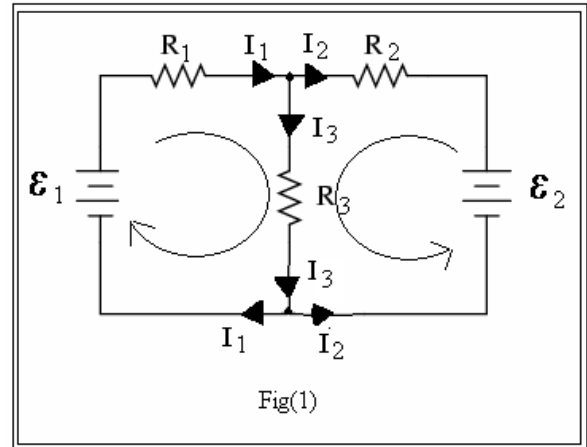

Solving these three linear equations with three unknowns is straight forward and yields the values of the currents passing through the three resistors.

Note: If any current is found to be negative, its assigned direction must be reversed.

The Superposition Principle (SPP)

If circuit equations are linear, then the mathematical superposition principle which states that: **The response " a desired current or voltage " at any point in a linear circuit having more than one source can be obtained as the sum of the responses caused by each of the independent sources acting alone,** is applicable.

Therefore, a circuit that contains independent and/or linear sources and linear circuit components such as resistors, capacitors and inductors can be analyzed as in the following example.

Example:

In the circuit of Fig(I) find the current passing through R_3 .

1- Keep ε_1 , and replace, with a short circuit (see Fig(2)) (a voltage sources is replaced by a short circuit but a current source is replaced by an open circuit).

2- Find the current passing through R_3 as a result of the presence of ε_1 , alone, as follows:

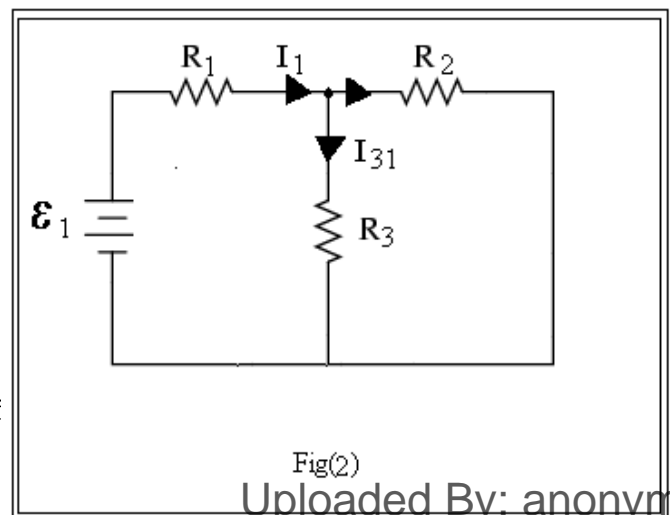

$$I_1 = \frac{\varepsilon_1}{R_1 + (R_2 // R_3)}$$

and

$$I_{31} R_3 = (I_1 - I_{31}) R_2$$

Thus,

$$I_{31} = \frac{\varepsilon_1 R_2}{R_1 R_2 + R_1 R_3 + R_2 R_3}$$

3- Keep ε_2 and replace ε_1 by a short as shown in Fig(3).

4- Find the current passing through R_3 as a result of the presence of ε_2 alone, as follows.

$$I_2 = \frac{\varepsilon_2}{R_2 + (R_1 // R_3)}$$

and

$$I_{32} R_3 = (I_2 - I_{32}) R_1$$

Those give:

$$I_{32} = \frac{\varepsilon_2 R_1}{R_1 R_2 + R_2 R_3 + R_1 R_3}$$

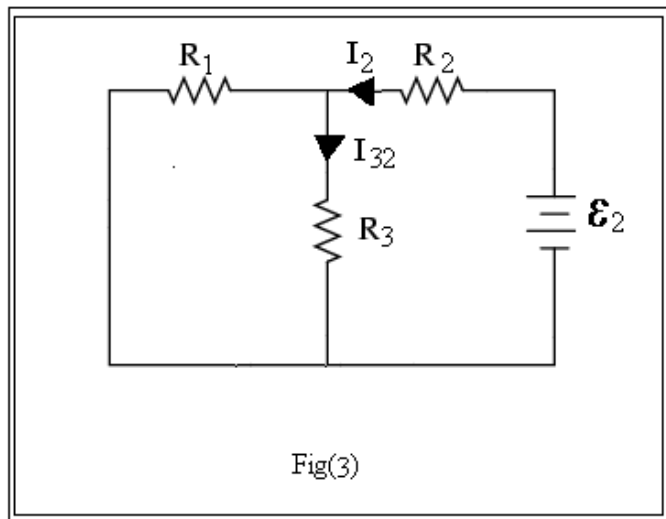

Fig(3)

5- Add both currents to find the total current passing through R_3 .

$$(3) \quad I_3 = I_{31} + I_{32}$$

Apparatus

Two power supplies, three carbon resistors, a circuit board and a digital multimeter.

Procedure

- Connect the circuit shown in Fig(4).
- Measure the voltage differences across the three carbon resistors and the current passing through each of them.
- Replace ε_2 by a short and repeat part (b).

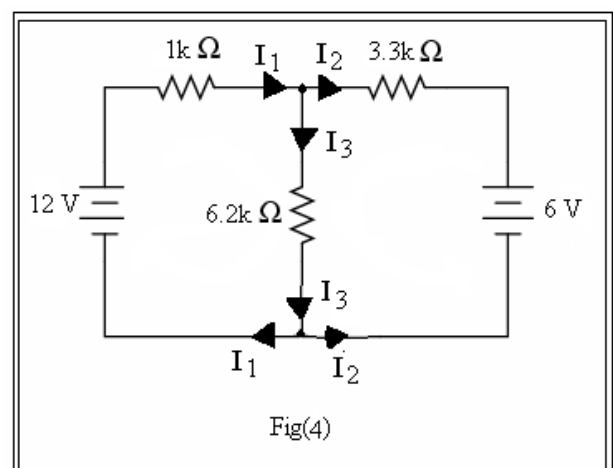

Fig(4)

d) Connect ε_2 back, replace ε_1 by a short and repeat part (b).

Analysis of results

I. Superposition principle (SPP):

Using SPP, analyze the circuit to find the value of the current passing through R_3 when each source is acting alone. Compare the values obtained with the practical measurements. Use your data to prove equation (3).

II. Kirchhoff's Laws:

Analyze the circuit using Kirchhoff's rules. Find the values of the currents passing through the three carbon resistors. Compare with the values obtained from the experiment.

Question: To what extent do the two methods give the same value for the current passing through R_3 ?

EXPERIMENT 4

NETWORK ANALYSIS II

THE THEVENIN AND NORTON TECHNIQUES

Theory

Kirchoff's laws and the Superposition principle are useful techniques for analyzing networks that contain a few circuit elements. Dealing with fairly complicated networks, however, requires more adequate methods such as the equivalent circuit techniques of *Thevenin and Norton*.

Thevenin's theorem states that: **any network of resistors and supplies having two output terminals (see Fig(1)) can be replaced by a series combination of a voltage source (ϵ_{eq}) and a resistor (R_{eq}),** see Fig(2). Thevenin's technique is especially important in obtaining the current passing through and/or the voltage across any one resistor (R_L) in a complicated network. Thevenin suggested the following method to find ϵ_{eq} and R_{eq} :

- 1- Remove R_L and calculate the voltage difference at the network output terminal. Call this value ϵ_{eq} .
- 2- Remove R_L , kill all the sources in the network through replacing voltage sources by short circuits and current sources by open circuits (see Fig(3)). Calculate the network equivalent resistance at the output terminals (between a and b). Call this value R_{eq} .
- 3- Construct Thevenin's equivalent circuit as in Fig(2). Calculate the current passing through, and the voltage drop across, R_L . Those should be the same values obtained in the original network.

Norton suggests a similar technique that goes along the following lines:

- 1- Use exactly the same procedure used by Thevenin to find R_{eq} .
- 2- Replace R_L by a short circuit (a wire), see Fig(4), and calculate the current passing through the wire, call it I_{eq} .

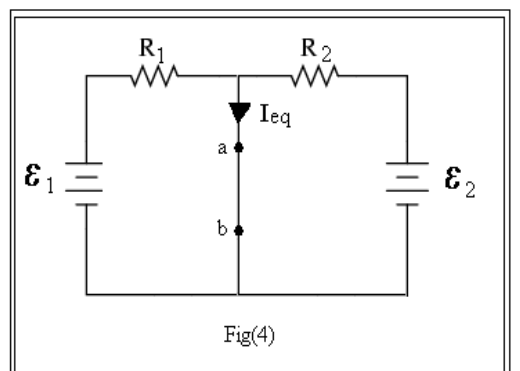
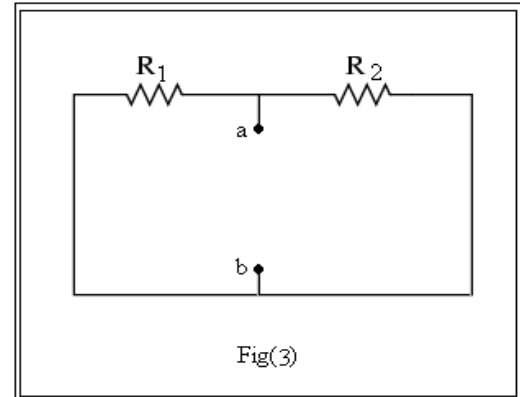
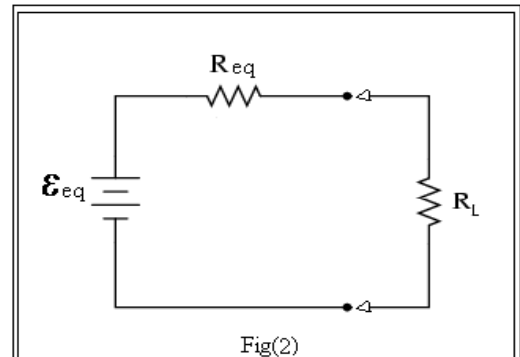
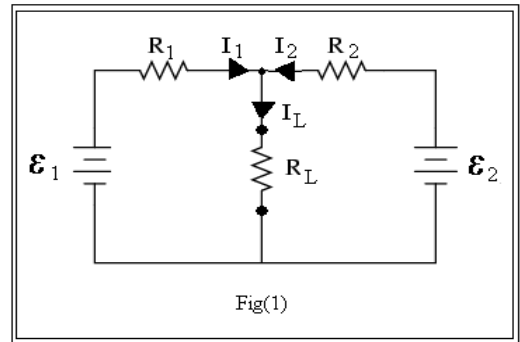

3- Construct Norton's equivalent circuit using a current source and a parallel resistance, as in Fig(5). Calculate the current passing through and the voltage difference across, R_L . Those should be the same values obtained in the original network.

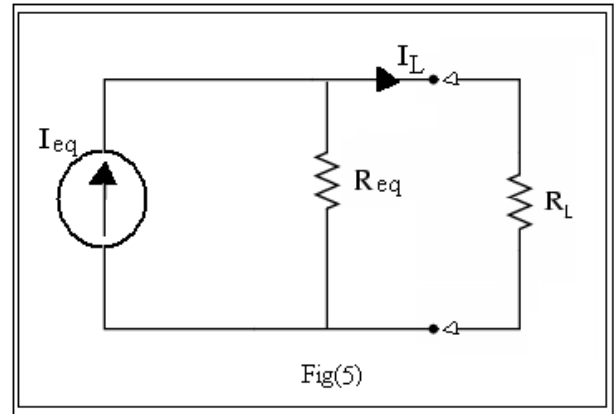

Example:

For the circuit in Fig(1), use Thevenin's and Norton's equivalent circuit techniques to find the value of the current passing through R_L .

I) Thevenin's:

1- Remove R_L , kill both sources as in Fig(4), and you will get :

$$(1) \quad R_{eq} = R_1 // R_2 = \frac{R_1 R_2}{R_1 + R_2}$$

2- Remove R_L , return both sources back to the circuit as in Fig(6), and calculate ϵ_{eq} as follows:

Using Kirchoff's loop theorem we get :

$$\begin{aligned} \epsilon_1 - \epsilon_2 &= I(R_1 + R_2), \\ \epsilon_{eq} &= \epsilon_1 - IR_1, \end{aligned}$$

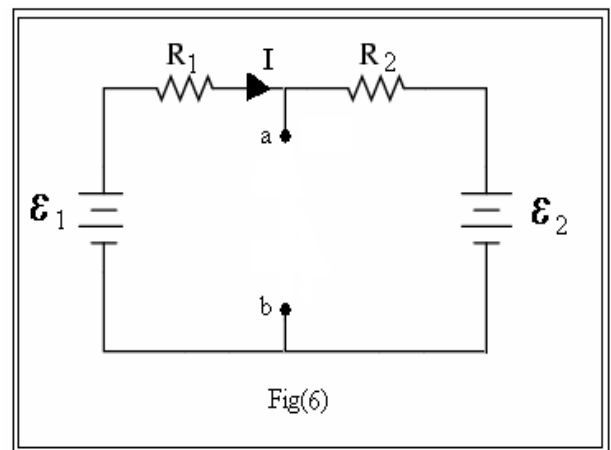

Eliminating I between the two equations, yields:

$$(2) \quad \epsilon_{eq} = \epsilon_1 - \frac{(\epsilon_1 - \epsilon_2)R_1}{R_1 + R_2}$$

3- Construct Thevenin's equivalent circuit as in Fig(2) using the calculated values of ϵ_{eq} and R_{eq} . Now, you can find the current passing through R_L as follows:

$$(3) \quad I_{R_L} = \frac{\epsilon_{eq}}{R_{eq} + R_L}$$

II) Norton's:

1- Replace R_L with a short circuit (a wire) as in Fig(4), and calculate I_{eq} as follows:

$$(4) \quad I_{eq} = I_1 + I_2$$

$$(5) \quad I_{eq} = \frac{\epsilon_1}{R_1} + \frac{\epsilon_2}{R_2}$$

2- Construct Norton's equivalent circuit, Fig(5), and calculate the current passing through R_L as follows:

$$(6) \quad (I_{eq} - I_{R_L})R_{eq} = I_{R_L}R_L,$$

$$(7) \quad I_{R_L} = \frac{I_{eq}R_{eq}}{R_{eq} + R_L}$$

Problem: Prove the equivalence of equations (3) and (7).

Apparatus

Two voltage supplies, circuit board, digital multimeter, three carbon resistors.

Procedure

- Connect the circuit shown in Fig(7).
- Remove R_L , kill both sources and measure the value of R_{eq} .
- Connect the sources back and measure ϵ_{eq} .
- Replace R_L by a short circuit (a wire) and measure I_{eq} .
- Construct Thevenin's equivalent circuit, and measure I_{eq} .
- Construct Norton's equivalent circuit.

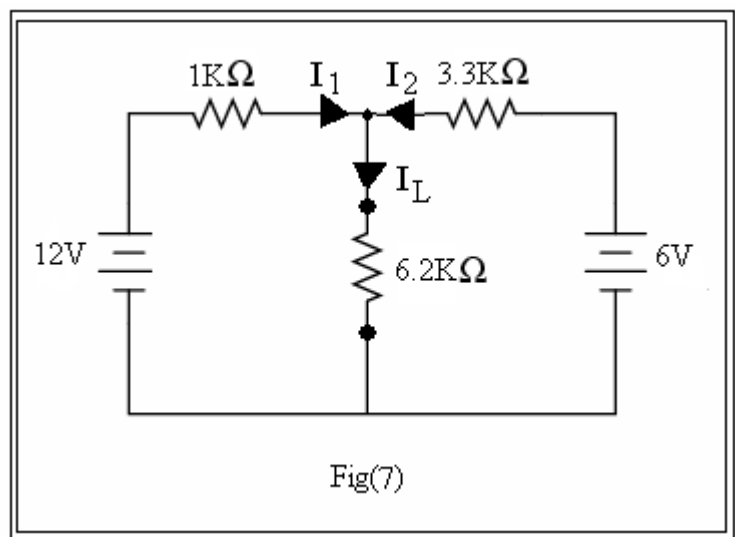

Analysis of results

Calculate the values of I_{eq} , ϵ_{eq} , R_{eq} , I_{RL} , and compare them with your experimental results.

EXPERIMENT 5

Digital Storage Oscilloscope

(You will get a hand out before the lab)

GENERAL REVIEW 2

ALTERNATING CURRENT CIRCUITS

Capacitor and inductor behavior in DC circuit

Capacitors

The simplest form of a capacitor is two metal plates separated by an insulating material (see Fig(1)). When connected to a DC power supply, positive charge will accumulate on one of the capacitor plates and an equal negative charge will accumulate on the other. This charge configuration results in the build up of an electric field between the capacitor plates (see Fig(1)). This process is described as charging the capacitor. If the two plates of a charged capacitor are connected together, the capacitor will discharge so that each of its plates becomes neutral. Each capacitor is characterized by its capacitance(C) which is the amount of charge accumulated on one of its plates divided by the voltage difference across it. Symbolically,

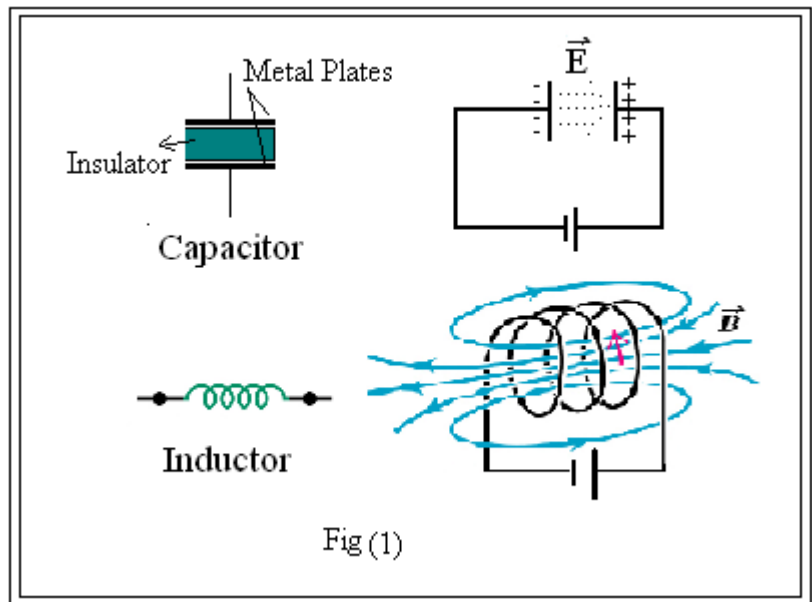

(1)

$$C = \frac{Q}{V}$$

The unit of capacitance is the Farad (F).

Inductors:

The simplest form of an inductor is a wound wire (see Fig(t)). When connected to a DC power supply, a magnetic field build up in the vicinity of the inductor (see Fig(1)). Each inductor is characterized by its Inductance (L). The relation between L and the voltage difference across the inductor terminals and the current passing through it is given by:

(2)

$$V = -L \frac{dI}{dt}$$

The unit of inductance is the Henry (H)

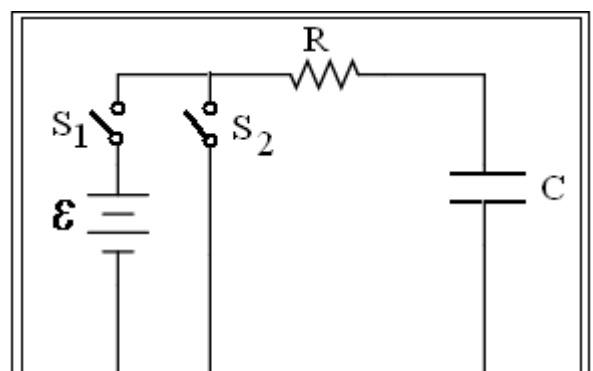

DC driven RC circuit:

A DC driven RC circuit is a circuit that contains a resistor and a capacitor connected in series and powered by a DC power supply (see Fig(2) with switch S_1 closed and switch S_2 open). Using Kirchoff's loop theorem we obtain the following equation:

$$\begin{aligned}\varepsilon &= IR + V_c \\ \varepsilon &= R \frac{dQ}{dt} + \frac{Q}{C}\end{aligned}$$

Rearranging we get:

$$\frac{dQ}{\frac{\varepsilon}{R} - \frac{Q}{RC}} = dt$$

integrating both sides as follows

$$\int_0^{Q(t)} \frac{dQ}{\frac{\varepsilon}{R} - \frac{Q}{RC}} = \int_0^t dt$$

and solving for Q, we get:

$$(3) \quad Q(t) = C\varepsilon(1 - e^{-\frac{t}{RC}})$$

This equation describes how the capacitor is charged with time.

If after the capacitor is charged, switch S_1 is opened and S_2 closed the circuit equation becomes:

$$0 = R \frac{dQ}{dt} + \frac{Q}{C},$$

and its solution, using simple integration methods as in the charging case is :

$$(4) \quad Q = C\varepsilon e^{-\frac{t}{RC}}$$

This equation describes how the capacitor discharges with time. Fig(3) represents relation between (Q) and (t) in both charging and discharging processes. "RC" has units of time and is called the time constant of the circuit; it is the time required for the charge on the capacitor to reach about 63% of its final charge during charging.

DC driven RL circuit:

A DC driven RL circuit is a circuit that contains an inductor connected in series with a resistance and powered by a DC

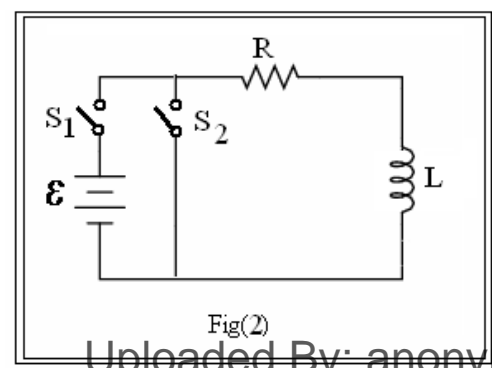
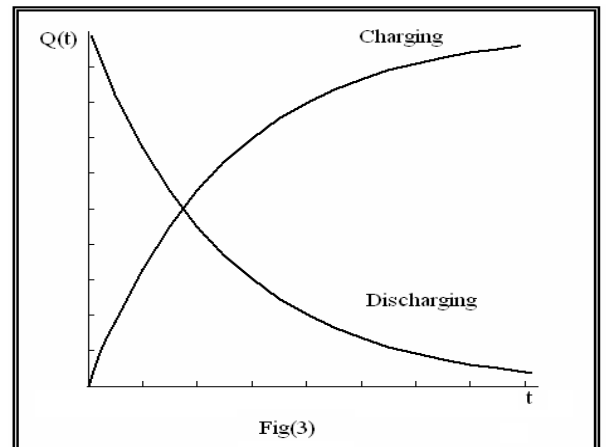

power supply (see Fig(4)). The circuit equation is given by:

$$\varepsilon = IR + L \frac{dI}{dt}$$

The solution is found using methods similar to those used in the RC circuit case.

$$(5) \quad I = \frac{\varepsilon}{R} (1 - e^{-\frac{Rt}{L}})$$

This equation describes how the current rises in the circuit.

If the power supply is shorted (replaced by a wire), then the circuit equation becomes:

$$0 = L \frac{dI}{dt} + RI,$$

the solution of which is:

$$(6) \quad I = \frac{\varepsilon}{R} e^{-\frac{Rt}{L}}$$

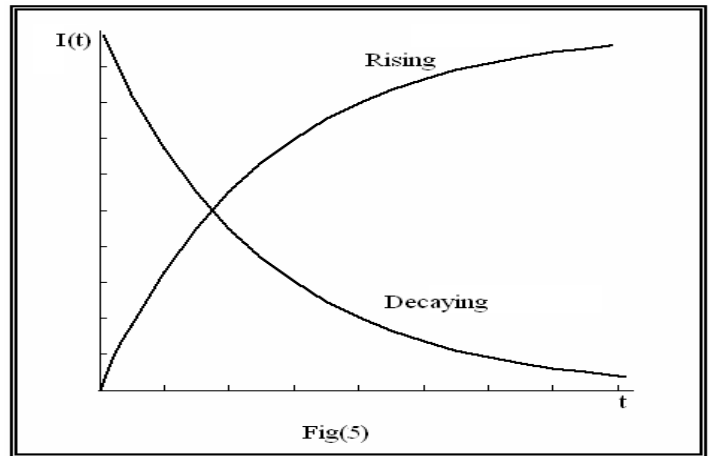

This equation describes how the current decays in the circuit. Fig(5) represents the relation between (I) and (t) for both rising and decaying currents. " L/R " has units of time and is called the time constant of this circuit.

DC driven LC circuit:

The circuit in Fig(6) is a series LC circuit powered by a DC power supply. The circuit equation is:

$$\varepsilon = L \frac{d^2Q}{dt^2} + \frac{Q}{C}$$

If the circuit is connected to the supply (S1 is closed) until the capacitor is charged then the supply is replaced by a short, the circuit equation becomes:

$$L \frac{d^2Q}{dt^2} = -\frac{1}{LC} Q$$

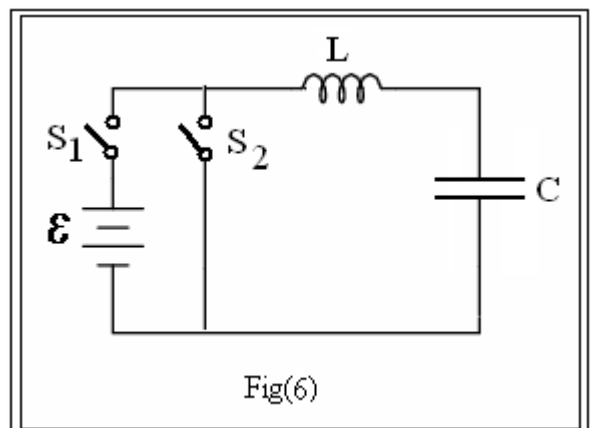

This is an equation of a *simple harmonic oscillator* with an angular frequency ω_0 defined as:

$$\omega_0 = \frac{1}{\sqrt{LC}}$$

Such a circuit is called an LC tank or an LC oscillator, with ω_0 as its natural angular frequency of oscillation. The solution of the simple harmonic oscillator is a sinusoidal function. In mathematical form:

$$(7) \quad Q(t) = A \cos(\omega_0 t),$$

where A is a constant.

In reality it is never possible to construct a pure LC circuit. Various sources of resistance cause a continuous loss of power as heat; consequently, the simple harmonic oscillations will sooner or later decay.

DC driven RLC circuit:

The circuit in Fig(7) is a simple series RLC circuit powered by a DC supply. Using Kirchhoff's loop theorem, the circuit equation takes the following form:

$$\varepsilon = IR + L \frac{dI}{dt} + \frac{Q}{C},$$

which, using the definition of the current, could be written as follows:

$$\varepsilon = R \frac{dQ}{dt} + L \frac{d^2Q}{dt^2} + \frac{Q}{C}$$

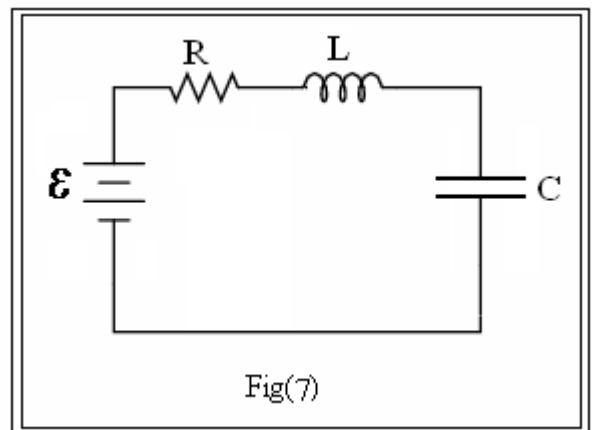

The solution of this second order linear differential equation is mathematically involved*, therefore, we only introduce the result:

$$(8) \quad Q(t) = A_1 e^{\lambda_+ t} + A_2 e^{\lambda_- t},$$

where A_1 and A_2 are constants and

$$\lambda_+ = -\frac{R}{2L} + \sqrt{\left(\frac{R}{2L}\right)^2 - \frac{1}{LC}}$$

$$\lambda_- = -\frac{R}{2L} - \sqrt{\left(\frac{R}{2L}\right)^2 - \frac{1}{LC}}$$

This solution is an exponentially decaying one. As this solution decays to zero within a limited period of time, it is called a transient solution. The significance of this solution will be discussed in detail through experiment (6).

* See appendix B for a comprehensive summary of solving second order linear differential equations.

The response of resistors, capacitors and inductors to AC signals

If a resistor is connected to an AC supply then the current flowing in the resistor is related to the voltage through Ohm's law as

$$I(t) = \frac{\varepsilon(t)}{R},$$

where,

$$\varepsilon(t) = \varepsilon_0 \cos(\omega t),$$

therefore,

$$(9) \quad I(t) = \frac{\varepsilon_0}{R} \cos(\omega t) = I_0 \cos(\omega t)$$

The current is also a sinusoidal function of time.

The root mean square (rms) value:

A resistance, with an alternating sinusoidal current passing through, dissipates power by means of joule heating by an amount equal to that dissipated if it were a direct current I passing through it. The *rms* current (I_{rms}) is given by :

$$I_{rms} = \frac{I_0}{\sqrt{2}}$$

Therefore, if we take the (rms) value of both the driving voltage and the current, Ohm's law takes the following form:

$$(10) \quad I_{rms} = \frac{\varepsilon_{rms}}{R}$$

Which is Ohm's law generalized for an AC current; R here is best describes the resistive impedance.

If a capacitor is connected to an AC source then the current is given by:

$$I(t) = C \frac{d}{dt} \varepsilon(t),$$

Hence,

$$I(t) = -C\varepsilon_0 \omega \sin(\omega t),$$

or,

$$I(t) = \frac{\varepsilon_0 \cos(\omega t + \frac{\pi}{2})}{\frac{-1}{\omega C}}$$

Taking root mean square value of both the current and the voltage we get:

$$(11) \quad I_{rms} = \frac{\varepsilon_{rms}}{\frac{-1}{\omega C}},$$

Which is again the generalized Ohm's law with $(-1/\omega C)$ termed the capacitive reactance.

Now, if an inductor is connected to an AC supply, and because the self-induced emf ε_s is given by:

$$\varepsilon_s = -L \frac{dI}{dt},$$

Then the current passing through the inductor is :

$$I(t) = \int \frac{\varepsilon(t) dt}{L}$$

Solving the integral and taking the root mean square value we get,

$$(12) \quad I_{rms} = \frac{\varepsilon_{rms}}{\omega L}$$

0

Once again this is the generalized Ohm's law with (ωL) the inductive reactance.

AC Driven RLC Circuits:

Shown in Fig(8) is a series RLC circuit powered by a sinusoidal AC source. The circuit equation in this case is:

$$\varepsilon(t) = L \frac{d^2 Q}{dt^2} + R \frac{dQ}{dt} + \frac{Q}{C},$$

where,

$$\varepsilon(t) = \varepsilon_0 \cos(\omega t)$$

The solution of this second order linear differential equation is as the sum of two parts, one is called the homogenous solution and the other is called the particular solution. The homogenous solution is the transient solution given by equation(8). This solution has an effect only when the circuit is switched on or off and dies exponentially and rapidly with time. The particular solution for the current passing

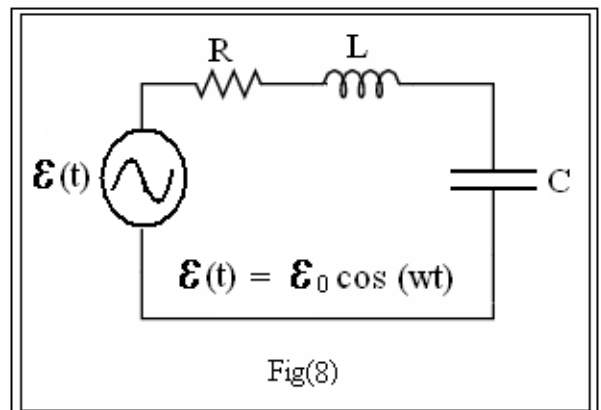

through the circuit is presented here without mathematical treatment as:

$$(13) \quad I(t) = I_0 \cos(\omega t + \phi),$$

where,

$$(14) \quad I_0 = \frac{\varepsilon_0}{\sqrt{R^2 + (\omega L - \frac{1}{\omega C})^2}},$$

and

$$(15) \quad \Phi = \tan^{-1}\left(\frac{-\omega L + 1/\omega C}{R}\right)$$

Note that the current in the circuit is also sinusoidal with an introduced phase shift (Φ) and an amplitude that is dependent on frequency.

Generalized Ohm's Law: *Impedance and Reactance*

A resistor as a circuit element is characterized by its resistance. Can we assign similar characteristics to capacitors and inductors in AC circuits?

Let us define a resistive impedance Z_R , a capacitive impedance Z_C and an inductive impedance Z_L as follows:

$$(16) \quad \begin{aligned} Z_R &= R \\ Z_C &= -\frac{j}{\omega C} \\ Z_L &= j\omega L \end{aligned}$$

The unit of impedance is the Ohm (Ω) and $j = \sqrt{-1}$; hence, the impedance is defined as a complex number.

For the simple series RLC circuit of Fig(8), the current passing through the circuit is given by:

$$(17) \quad I(t) = \frac{\varepsilon(t)}{Z_{eq}}, \quad (\text{Generalized Ohm's Law})$$

where,

$$(18) \quad Z_{eq} = Z_R + Z_C + Z_L.$$

Therefore,

$$(19) \quad I(t) = \frac{\varepsilon(t)}{R + j(\omega L - \frac{1}{\omega C})}.$$

And the physical (non-complex) value of the current is obtained as (see appendix C):

$$I(t) = \frac{\varepsilon_0 \cos(\omega t + \Phi)}{\sqrt{R^2 + (\omega L - \frac{1}{\omega C})^2}},$$

where Φ is defined as in equation (15). This is the same value obtained from the solution of the second order linear differential equation.

This technique in circuit analysis; i.e. using the definitions of equation (16), which can be summarized by the following steps, is useful for all AC circuits:

- Assign an impedance to each circuit element in the circuit. .
- Find the equivalent impedance through applying the rules of series and parallel connection or by other advanced techniques such as Thevenin's.
- Find the current equation by dividing the supply's electro motive force by the equivalent impedance of the circuit. .
- Use the mathematical rules and techniques of complex numbers* to find the physical value of the current.

EXPERIMENT 6

CAPACITORS AND INDUCTORS

Theory

i. RC Circuits

Charging a capacitor:

During the positive half period of the square wave, the charge in the simple RC circuit shown in Fig(1) builds up on the capacitor plates according to the following formula:

$$Q(t) = C\varepsilon(1 - e^{-\frac{t}{RC}}).$$

The voltage across the capacitor plates is defined by

$$V_C = \frac{Q}{C},$$

hence,

$$(1) \quad V_C = \varepsilon(1 - e^{-\frac{t}{RC}}).$$

RC is usually called the time constant (τ) of the RC circuit. τ has the unit of time (sec) and is measure of how fast the voltage across the capacitor rises. When $t = \tau$,

$$V_C = 0.63\varepsilon,$$

or, the voltage across the capacitor rises to 0.63 of its maximum value.

The current passing through the circuit is given by:

$$I(t) = \frac{dQ}{dt} = \frac{\varepsilon}{R} e^{-\frac{t}{RC}}.$$

Therefore, the voltage across the resistor is

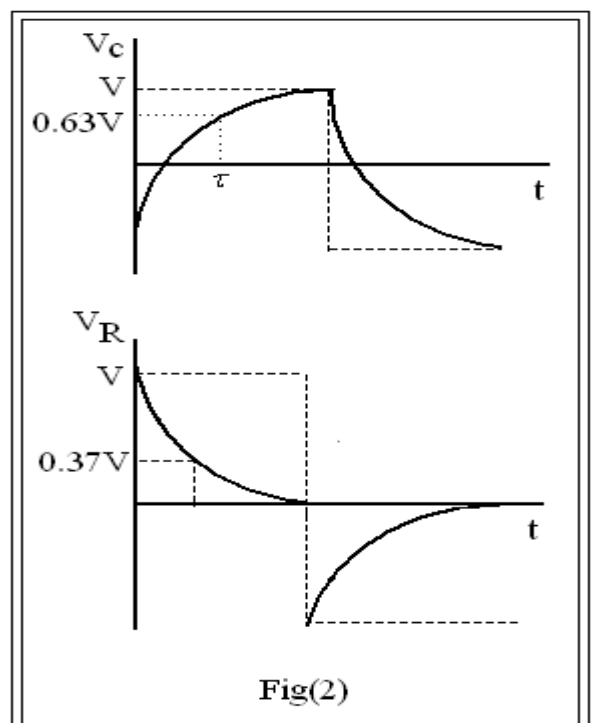
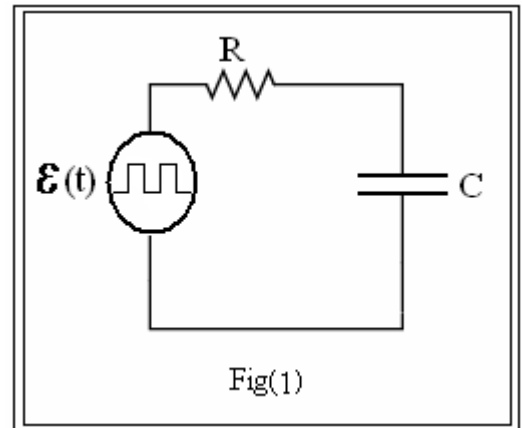

$$(2) \quad V_R = I(t)R = \varepsilon e^{-\frac{t}{RC}}.$$

Discharging a capacitor:

During the negative half period of the square wave, the capacitor, in the RC circuit of Fig(1), discharge according to the following formula:

$$Q(t) = C\varepsilon e^{-\frac{t}{RC}}.$$

Hence, the voltage across the capacitor plates is given by:

$$(3) \quad V_C = \varepsilon e^{-\frac{t}{RC}}.$$

RC is again called the time constant (τ) of the circuit; it is a measure of how the fast the voltage across the capacitor plates decreases. When $t = \tau$,

$$V_C = 0.37\varepsilon,$$

or, the voltage across the capacitor plates decays to 0.37 of the maximum value within a time τ .

The current passing through the circuit is

$$I(t) = \frac{dQ}{dt} = -\frac{\varepsilon}{R} e^{-\frac{t}{RC}},$$

thus, the voltage across the resistor is given by:

$$(4) \quad V_R = I(t)R = -\varepsilon e^{-\frac{t}{RC}}.$$

The graphs in Fig(2) show the functional relation between both the voltage across the capacitor and the resistor and the time for both charging and discharging.

ii. RL Circuits

In Fig(3), the current passing through the circuit rises with the according to the following equation:

$$I(t) = \frac{\varepsilon}{R} (1 - e^{-\frac{Rt}{L}}).$$

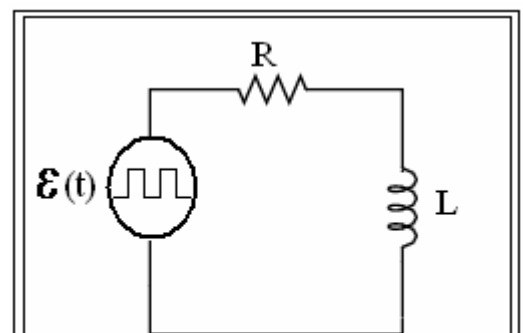

Fig(3)

Uploaded By: anonymous

The voltage across the resistor is:

$$(5) \quad V_R = IR = \varepsilon(1 - e^{-\frac{Rt}{L}}),$$

and the voltage across the inductor is:

$$(6) \quad V_L = L \frac{dI}{dt} = \varepsilon e^{-\frac{Rt}{L}}.$$

The quantity L/R is called the time constant (τ) of the circuit; it is measure of how fast the current rises in the circuit. When $t = \tau$,

$$V_R = 0.63\varepsilon,$$

and

$$V_L = 0.37\varepsilon.$$

The graphs of Fig(4) show both V_L and V_R a function of time.

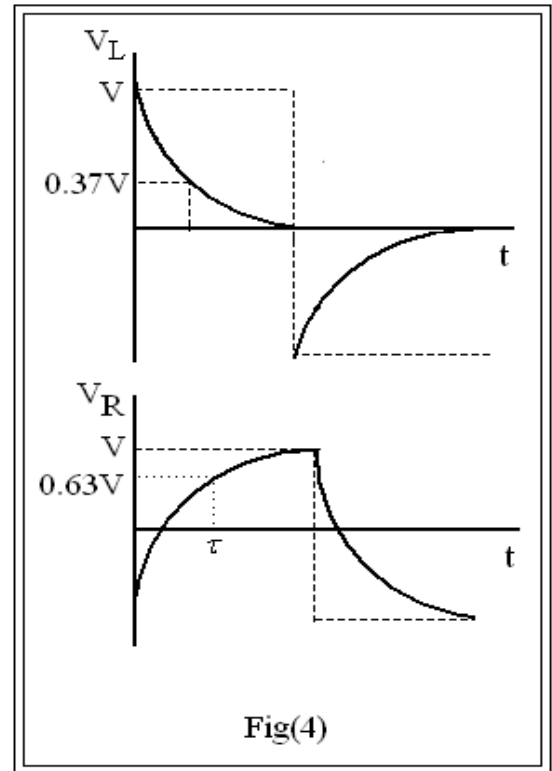

iii. LC Circuits

In the circuit of Fig(5), the voltage across the capacitor plates is described through the following equation:

$$(7) \quad V_C = V_{C0} \cos(\omega t + \Phi),$$

where, V_{C0} is the amplitude (constant) and

$$(8) \quad \omega = \frac{1}{\sqrt{LC}}.$$

Fig(6) shows the voltage across the capacitor as a function of time.

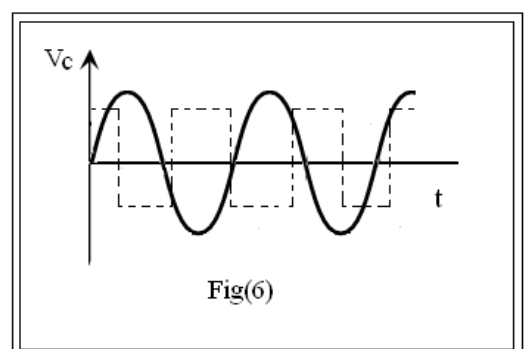
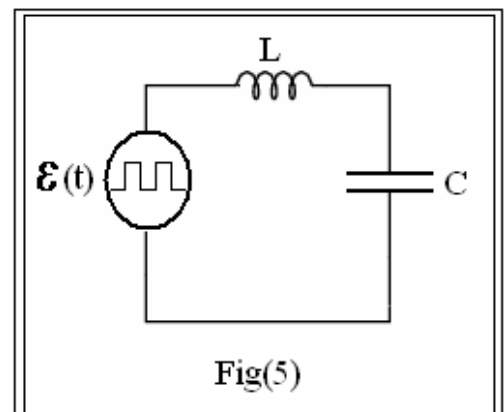

Apparatus

Resistor (5 k Ω), Inductor (10 mH), Capacitor (0.01 μ F), Signal Generator, and an Osilloscope.

Procedure

i- RC Circuits

- Connect the circuit of Fig(7).
- Use a square wave from the signal generator to power your circuit.

Note: a square wave operation on half cycle only acts as a DC supply.

- Display V_C on the Oscilloscope screen. Measure τ for both charging and discharging.
- Display V_R on the Oscilloscope screen. Measure τ for both charging and discharging.

Note: you have to exchange the places of R and C in the circuit (why?).

ii- RL Circuits

- Connect the circuit of Fig(8).
- Display V_R and V_L on the oscilloscope screen. Measure τ in both cases.

iii- LC Circuits

- Connect the circuit of Fig(9).
- Display V_C on the oscilloscope screen. Measure the amplitude A and the angular frequency ω .

Analysis of results

a) In both RC and RL circuits compare the values of τ obtained practically with the theoretically predicted ones.

b) For the LC circuit compare the measured value of ω with the theoretically predicted one and discuss the discrepancy.

Questions

1) For the RC circuit, explain what happens when $\tau \rightarrow 0$ and when $\tau \rightarrow \infty$?

2) Is it possible to operate the RL circuit or the RC circuit by a standard DC supply and to do time measurements using a stop watch? What values of R, L, and C make this option possible?

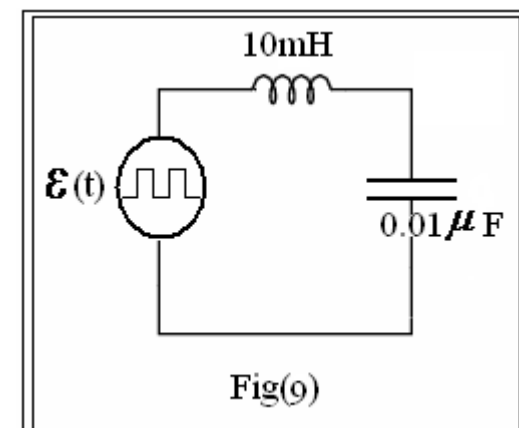
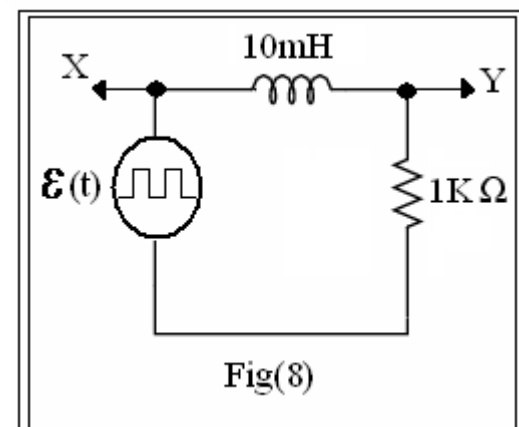
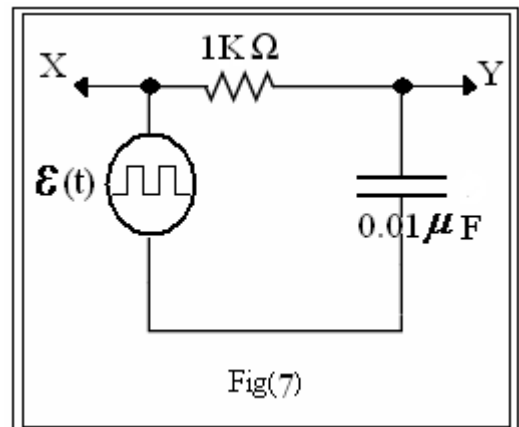

EXPERIMENT 7

DAMPED OSCILLATIONS

Theory

The charge on the capacitor plates and hence, the voltage across the capacitor in the DC powered RLC circuit shown in Fig(1) are described using the following solution for Q(t) (see general review2):

$$(1) \quad Q(t) = A_1 e^{\lambda_+ t} + A_2 e^{\lambda_- t},$$

where A_1 and A_2 are constants, and

$$(2) \quad \lambda_+ = -\frac{R}{2L} + \sqrt{\left(\frac{R}{2L}\right)^2 - \frac{1}{LC}},$$

$$\lambda_- = -\frac{R}{2L} - \sqrt{\left(\frac{R}{2L}\right)^2 - \frac{1}{LC}}.$$

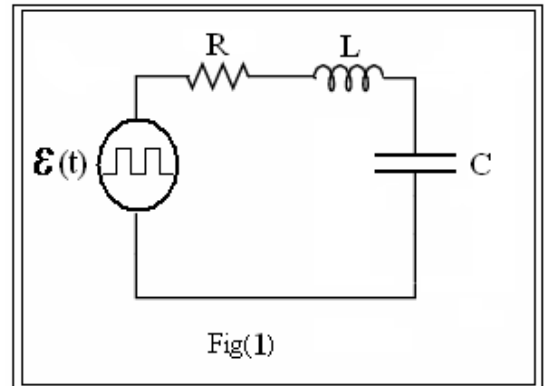

For this solution three interesting cases emerge.

case i: Over-damping

If

$$\left(\frac{R}{2L}\right)^2 > \frac{1}{LC},$$

then, both terms in equation(1) decay exponentially with time and the voltage across the capacitor is said to be over-damped, see Fig(2)

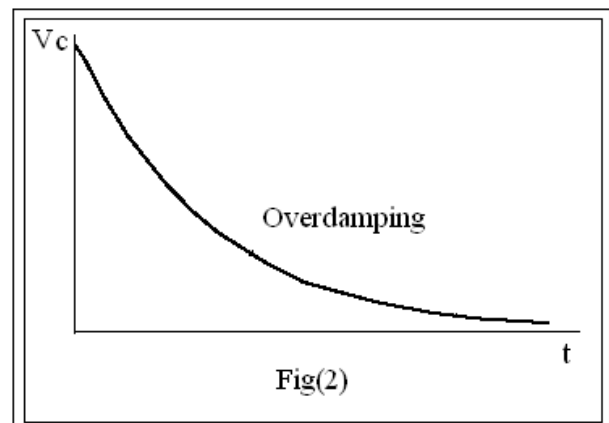

case ii: Critical damping

If

$$\left(\frac{R}{2L}\right)^2 = \frac{1}{LC},$$

then, the term under the square in equations(2) root vanishes and

$$\lambda_+ = \lambda_- = -\frac{R}{2L}.$$

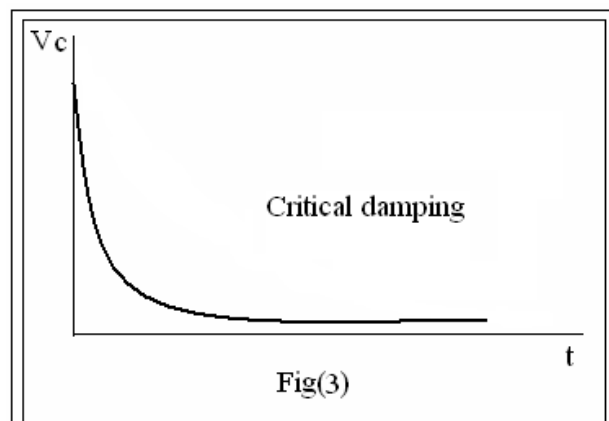

Therefore, the charge on the capacitor plates, and consequently the voltage across the capacitor plates take the following form:

$$(3) \quad Q(t) = Ae^{-\frac{R}{2L}t} + Be^{\frac{R}{2L}t},$$

where A and B are constants.

Again the charge on the capacitor plates, and consequently the voltage across them, decay exponentially with time, see Fig(3) This damping case is called critical damping and it serves as a boundary between over-damping and under-damping (discussed below).

case iii: Under-damping

If

$$\left(\frac{R}{2L}\right)^2 < \frac{1}{LC},$$

then, the term under the square root becomes negative.

The mathematical treatment of this case is beyond the scope of this course*, therefore, we only introduce the solution:

$$(4) \quad Q(t) = Q_0 e^{-\delta t} \cos(\omega' t + \theta_0),$$

where

$$(5) \quad \delta = \frac{R}{2L},$$

and

$$(6) \quad \omega' = \sqrt{\frac{1}{LC} - \left(\frac{R}{2L}\right)^2}.$$

This equation represents a sinusoidal function with an amplitude that is decaying exponentially, see Fig(4). This case is called under-damping. An interesting quantity is the time $t_{1/2}$ after which the amplitude (envelope) $Q_0 e^{-\delta t}$ falls to half its initial value Q_0 . Or,

$$\frac{Q_0}{2} = Q_0 e^{-\delta t_{1/2}}.$$

Substituting for δ from equation(5) and solving for $t_{1/2}$ gives:

$$(7) \quad t_{1/2} = \frac{(2L) \ln(2)}{R}.$$

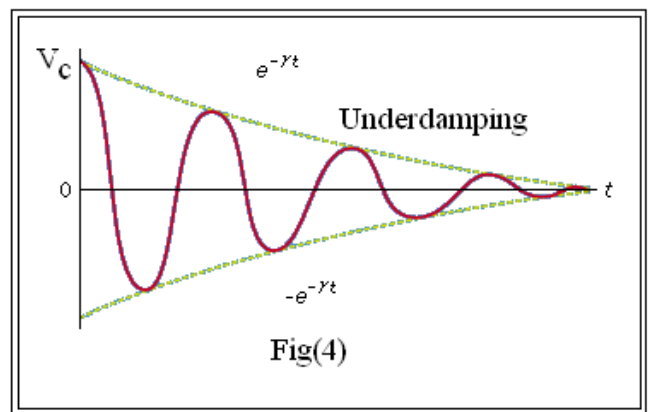

* In fact, using the properties of complex numbers introduced in appendix C with some trigonometric and algebraic maneuvers, a student at this level should readily get the desired result.

Experimentally, we measure the voltage across the capacitor. As usual the voltage is related to the charge through

$$V_C = \frac{Q(t)}{C},$$

hence, V_C behaves exactly the same as $Q(t)$ in all three cases.

Apparatus

Resistance decade box, 10mH inductor, 1 μ F capacitor, a signal generator and an oscilloscope.

Procedure

- Connect the circuit in Fig(s).
- Display the voltage across the capacitor on the oscilloscope screen.
- Change the value of R to obtain the three damping cases; record R in each case.
- Draw each response on a linear graph paper.

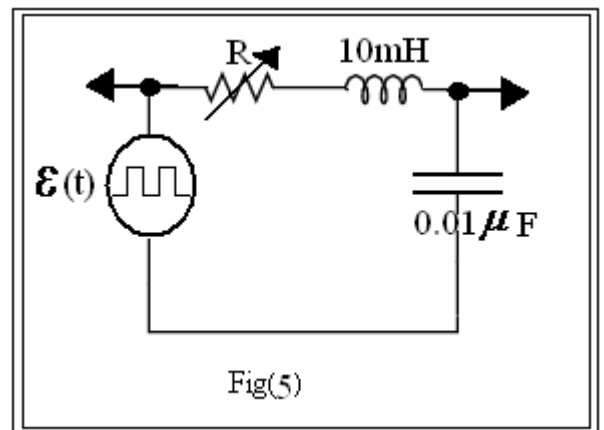

Analysis of results

- For underdamping find $t_{1/2}$ and compare it with the value calculated from component values.
- Define the value or the range of values of R in each case.
- Find the decay constant for the critical and overdamping cases and find which decays faster.

EXPERIMENT 8

IMPEDANCE AND REACTANCE

Theory

In the AC-powered RLC circuit shown in Fig(1), the current in the circuit is given by*

$$I(t) = \frac{\varepsilon(t)}{Z_{eq}}$$

where,

$$Z_{eq} = Z_R + Z_C + Z_L,$$

with

$$Z_R = R, \quad Z_C = -j/\omega C, \quad Z_L = j\omega L,$$

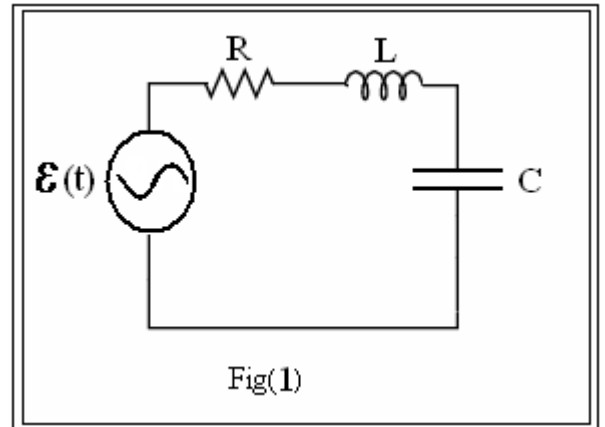

Z_R , Z_C , and Z_L being the resistive impedance, the capacitive impedance and the inductive impedance respectively. While the quantities $(1/\omega C)$ and (ωL) are the capacitive reactance and the inductive reactance respectively.

In general, impedance is a complex numbers that needs special mathematical treatment**. Proceeding with such treatment we get the following value for the current in the circuit:

(1)
$$I(t) = I_0 \cos(\omega t + \Phi),$$

where,

$$I_0 = \frac{\varepsilon_0}{\sqrt{R^2 + (\omega L - \frac{1}{\omega C})^2}},$$

and

$$\Phi = \tan^{-1}\left(\frac{-\omega L + 1/\omega C}{R}\right).$$

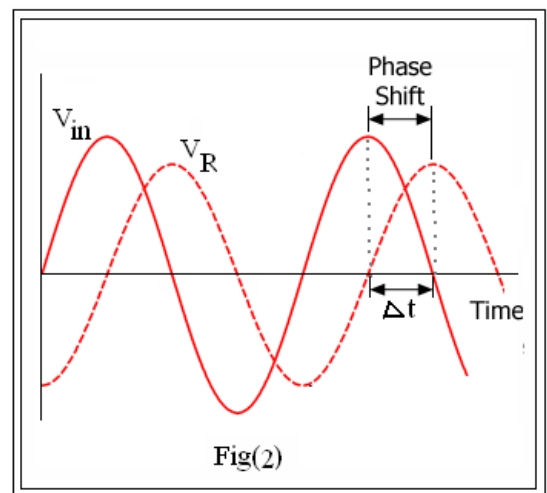

Fig(2) shows a plot of both the voltage and the current in the circuit on a common time scale. It is obvious from equation(1) that the current heads or lags the voltage by a time interval that is dependent on the frequency of the cosine function. In other words, there exists a phase shift $\Phi = \omega \Delta t$ between them.

* See general review2

*** Consult appendix C for a review of complex numbers.

The voltage across the inductor V_L can be obtained as follows:

$$V_L = L \frac{dI(t)}{dt} = L \frac{d}{dt} (I_0 \cos(\omega t + \Phi)),$$

$$(2) \quad V_L = -\omega L I_0 \sin(\omega t + \Phi)^*.$$

Note that V_L is just the current multiplied by the inductive reactance with a phase shift of $\pi/2$ introduced**. (Generalized Ohm's law)

The voltage across the resistor is

$$(3) \quad V_R = RI(t) = RI_0 \cos(\omega t + \Phi).$$

Note that V_R is just the current multiplied by the resistance.(Oh's law)

And finally, the voltage across the capacitor is

$$V_C = \frac{1}{C} \int I(t) dt = \frac{1}{C} \int I_0 \cos(\omega t + \Phi) dt,$$

$$(4) \quad V_C = \frac{I_0}{\omega C} \sin(\omega t + \Phi).$$

Note that V_C is just the current multiplied by the capacitive reactance with a phase shift of $\pi/2$ introduced.

The phase shifts between the current and the voltages across the different circuit elements in Fig(1) are also related to Φ which is a function of ω .

In order to find the value of the phase shift between two harmonic functions using the oscilloscope do the following:

- Set the oscilloscope on the x-y mode.
- Connect one function to the X-channel and the other to the Y-channel.
- On the screen you will see an ellipse (see Fig(3)).
- Let

$$V_X = V_{X0} \cos(\omega t)$$

and

$$V_Y = V_{Y0} \cos(\omega t + \Phi)$$

where Φ is the phase shift between the two functions.

- At point a, defined in Fig(3), V_X has its maximum value, therefore, $\omega t = 0$, and

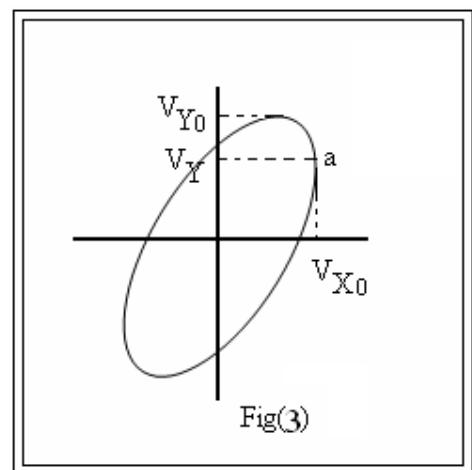

Fig(3)

* All phase shifts are related to the voltage of the source in the circuit.

** Note that: $\sin(\theta) = \cos(\theta + \pi/2)$.

$$V_Y = V_{Y0} \cos(\Phi).$$

Therefore,

$$\Phi = \cos^{-1}\left(\frac{V_Y}{V_{Y0}}\right).$$

Both V_Y and V_{Y0} are measured as shown in Fig(3).

Apparatus

1 k Ω resistor, 0.1 μ F capacitor, 10 mH inductor, signal generator, oscilloscope, circuit board.

Procedure

- Connect the circuit of Fig(4).
- For five different frequencies find the phase shift between the driving voltage and the current.
- Display V_R , V_C , and V_L on the oscilloscope screen and measure their characteristics. Measure the phase shift between each of them and the driving voltage.

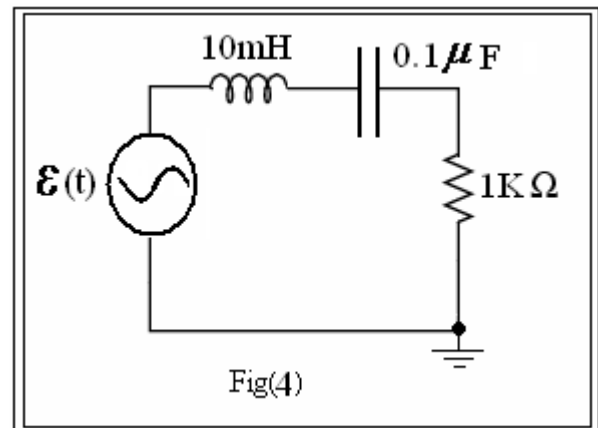

Analysis of results:

- Draw V_R , V_C , and V_L on the same graph paper showing similarities and differences.
- Draw the phase shift between the driving voltage and the current as a function of the frequency. Define the frequency at which the phase shift is zero.

EXPERIMENT 9

RESONANCE

Theory

Consider the AC-powered RLC circuit shown in Fig(1). The amplitude of the current passing through the circuit is given by,

$$(1) \quad I_0 = \frac{V_0}{\sqrt{R^2 + (\omega L - \frac{1}{\omega C})^2}}$$

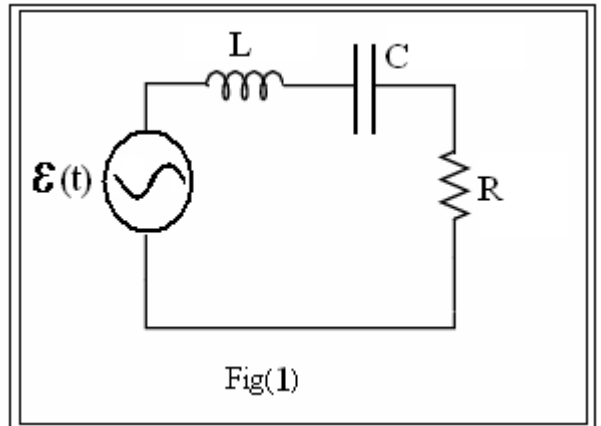

It is obvious that I_0 assumes a maximum as a function of ω when

$$\omega L = \frac{1}{\omega C}.$$

It is interesting to note that under such a condition ω is the natural angular frequency of the circuit:

$$(2) \quad \omega_0 = \frac{1}{\sqrt{LC}}.$$

In other words, the current in the circuit assumes its maximum value when the driving voltage frequency equals the natural frequency of the RLC circuit. This phenomenon is called resonance.

Fig(2) shows a plot of the value of I_0 as a function of ω . At resonance

$$(3) \quad I_0 = \frac{V_0}{R},$$

and the value of the current is only limited by the resistance of the circuit.

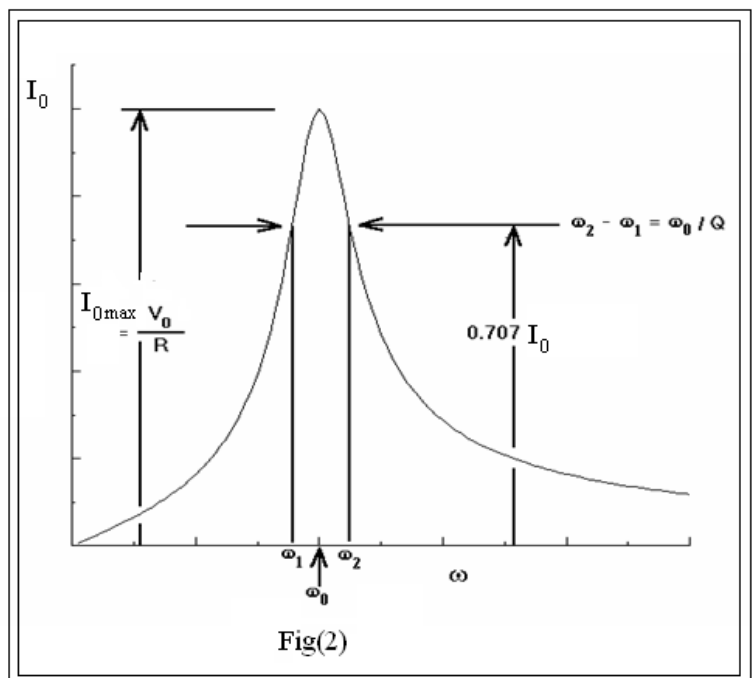

The Quality Factor:

A measure of the sharpness of the resonance curve is a quantity called the quality factor (Q), which is defined as

$$(4) \quad Q = \frac{\omega L}{R}.$$

At resonance

$$(5) \quad Q = \frac{1}{R} \sqrt{\frac{L}{C}}.$$

Fig(3) shows a plot of the resonance curve for different combinations of R, L and C.

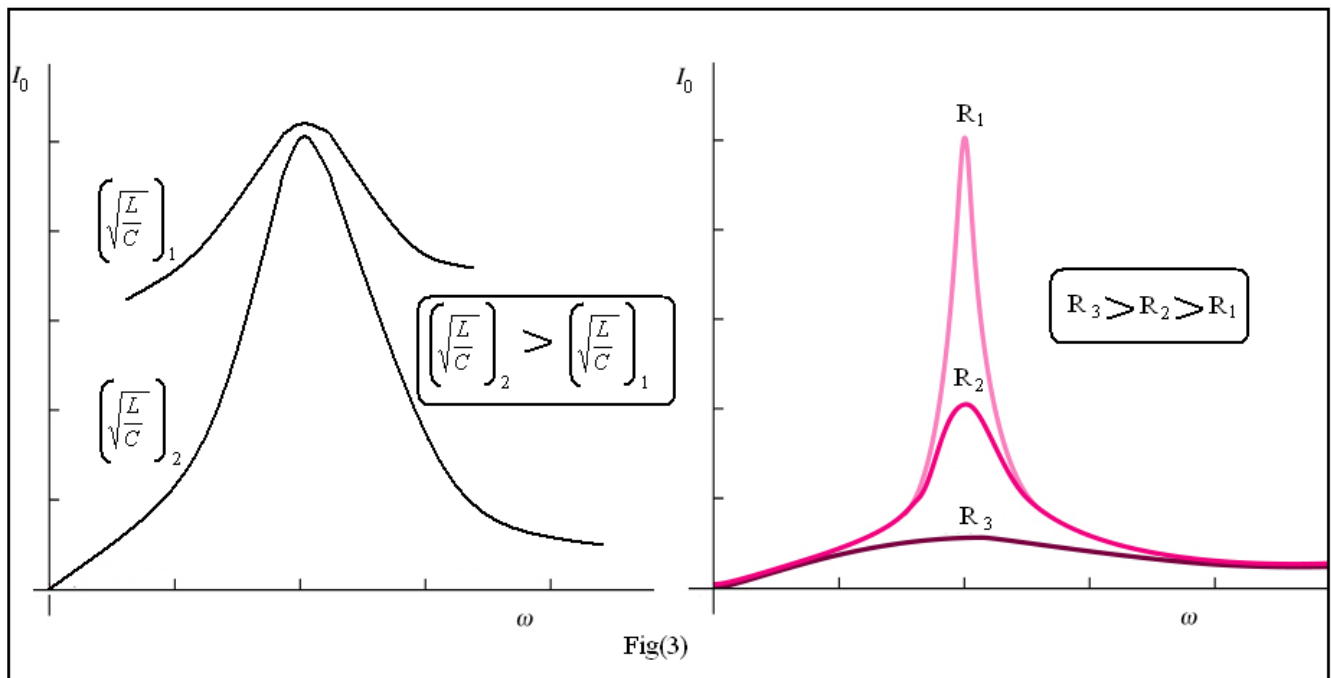

A practical value that measures the sharpness of the resonance curve is the bandwidth. The bandwidth ($\Delta\omega$) is the frequency range between the maximum value of I_0 and the value of $\frac{I_0}{\sqrt{2}}$, see Fig(2).

The quality factor is related to the bandwidth as follows:

$$(6) \quad Q = \frac{\omega_0}{|\Delta\omega|}.$$

Question: Show that $Q = \frac{1}{R} \sqrt{\frac{L}{C}}$.

Apparatus

1k Ω and 2k Ω resistors, 0.1 μ F capacitor, 10 mH inductor, signal generator, oscilloscope, circuit board and a digital multimeter.

Procedure

- Connect the circuit of Fig(4).
- For $R = 1\text{k}\Omega$ measure the current as a function of the input voltage frequency.
- Measure the phase shift between the current and the voltage in both cases. $f_{re}(q)$
- Repeat parts (b) and (c) for $R = 2\text{ k}\Omega$.

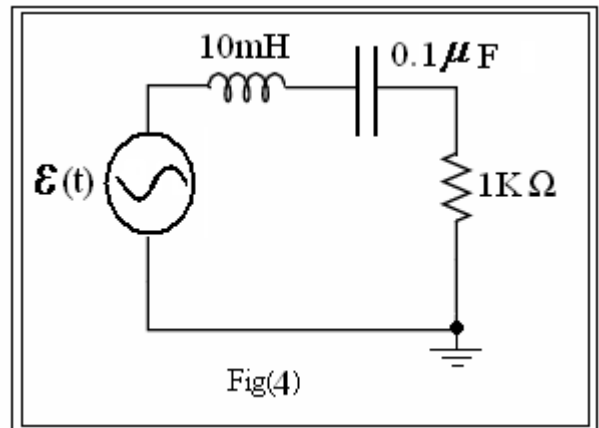

Analysis of results

- Plot I_0 as a function of the frequency for both cases.
- Measure the bandwidth for both resonance curves.
- Determine the resonance frequency and the quality factor in each case.
- Plot the phase shift as a function of frequency.

EXPERIMENT 10

RC FILTERS

Theory

A filter is an electrical circuit that allows signals with a defined frequency range to pass while blocking others with different frequency ranges. Filters are useful units in many electrical and electronic devices such as radio, TV, etc.

There are three types of filters: high pass, low pass and band pass filters, see Fig(1). In filters unwanted signals are highly attenuated* through the circuit while required signals are passed with, almost, no attenuation.

Low-pass RC filter

Consider the circuit of Fig(1a). Using the generalized Ohm's law we can obtain the output voltage, V_{out} , as a function of the input voltage, V_{in} , as follows.

- Find the circuit equivalent impedance:

$$Z_{eq} = R - \frac{j}{\omega C}$$

- Then, the current is

$$I(t) = \frac{V_{in}(t)}{Z_{eq}}$$

- The output voltage then becomes

$$V_{out}(t) = V_C(t) = \frac{V_{in}(t)}{R - \frac{j}{\omega C}} \left(\frac{-j}{\omega C} \right),$$
$$\Rightarrow V_{out}(t) = \frac{V_{in}(t)}{1 + j\omega RC}.$$

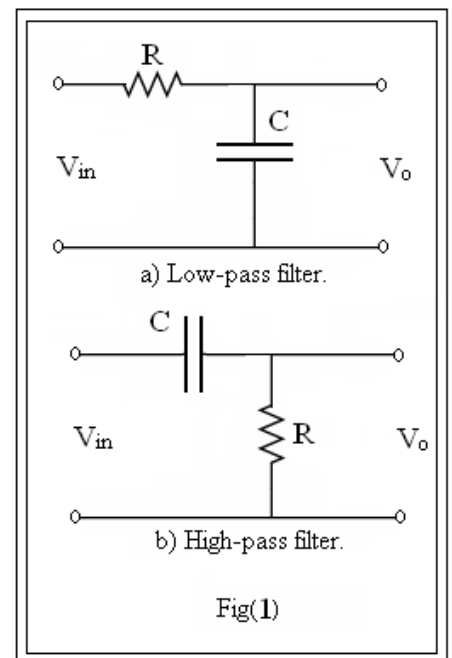

* Attenuation is the decrease in amplitude.

- Treating the complex numbers as described in appendix C will yield the following value for the amplitude of the output voltage:

$$V_{C0}(\omega) = \frac{V_{in0}}{\sqrt{1 + \omega^2 C^2 R^2}},$$

where V_{in0} is the amplitude of the input signal.

- The *attenuation factor*, A , is defined as follows:

$$A = \frac{V_{C0}}{V_{in0}} = \frac{V_{in0}}{\sqrt{1 + \omega^2 C^2 R^2}}.$$

- For reasons to be explained later. let us define

$$\omega_{-3dB} = \frac{1}{RC},$$

then, the attenuation factor takes the following form:

$$A = \frac{1}{\sqrt{1 + \left(\frac{\omega}{\omega_{-3dB}}\right)^2}}.$$

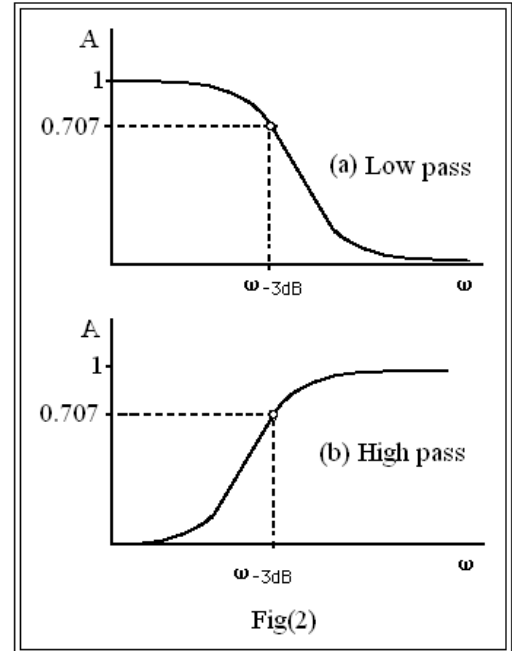

A careful Examination of this equation will yield the three following cases:

1. If $\omega \gg \omega_{-3dB}$ then A is extremely small and the output signal is highly attenuated.
2. $\omega \ll \omega_{-3dB}$ then $A \approx 1$ and the amplitude of the output signal is equal to that of the input signal, in other words, the signal is passed without attenuation.
3. If $\omega = \omega_{-3dB}$ then $A = 1/\sqrt{2} = 0.707$ and the amplitude of the output signal is 0.707 of the amplitude of the input amplitude. This value sets a practical boundary between passed signals and highly attenuated ones.

It is obvious from the above discussion that the circuit in consideration is acting as a low-pass filter, see Fig(2a).

High-pass RC filter

The circuit of Fig(lb) acts as a high-pass filter. The attenuation factor, A can be deduced using exactly the same procedure used in the case of the low pass filter; this gives:

$$A = \frac{1}{\sqrt{1 + \left(\frac{\omega_{-3dB}}{\omega}\right)^2}}$$

A careful examination of this equation will also yield three case:

1. If $\omega \ll \omega_{-3dB}$ then A is extremely small and the output signal is highly attenuated.
2. If $\omega \gg \omega_{-3dB}$ then $A \approx 1$ and the signal is passed without attenuation.
3. If $\omega = \omega_{-3dB}$ then $A = 1/\sqrt{2} = 0.707$ which again sets the boundary between passed signals and highly attenuated ones.

It is obvious from the above discussion that the circuit in consideration is acting as a high-pass filter, see Fig(2b).

Differentiators and Integrators

If a low pass filter is functioning in the highly attenuated region, where $\omega \gg \omega_{-3dB}$, then, $V_{out}(t)$ is extremely small and

$$V_R(t) = V_{in}(t) - V_{out}(t) \approx V_{in}(t).$$

On the other hand,

$$I(t) = \frac{dQ(t)}{dt} = C \frac{dV_C(t)}{dt} = C \frac{dV_{out}(t)}{dt},$$

so,

$$V_{in}(t) \approx V_R(t) = RI(t) = RC \frac{dV_{out}(t)}{dt}.$$

or equivalently,

$$V_{out}(t) = \frac{1}{RC} \int V_{in}(t) dt.$$

The output voltage is just the integral of the input voltage. Under such conditions this circuit acts as an integrator.

If an RC high-pass filter is functioning in the highly attenuated region, where $\omega \ll \omega_{-3dB}$, then, $V_{out}(t)$ is extremely small and

$$V_C(t) = V_{in}(t) - V_{out}(t) \approx V_{in}(t).$$

On the other hand,

$$I(t) = \frac{dQ(t)}{dt} = C \frac{dV_c(t)}{dt} = C \frac{dV_{in}(t)}{dt},$$

so,

$$V_{out}(t) = RI(t) = RC \frac{dV_{in}(t)}{dt}.$$

The output voltage is just the derivative of the input voltage. Under such conditions this circuit acts as a differentiator.

Apparatus

1kΩ resistor, 1μF capacitor, a circuit board, a signal generator and an oscilloscope.

Procedure

a) Connect the circuit of Fig(3a).

b) Measure the amplitude of the output voltage as a function of frequency.

Note: Scan a wide range of frequency. Be sure to include ω_{-3dB} in the range. Regularly check the input voltage to make sure it maintains the same value while changing the input frequency.

c) Check the phase shift between the input and the output voltages in both the high attenuation region and the region of no attenuation.

d) Use a sinusoidal, a square and a triangular signal with a frequency in the high attenuation region and plot the input and the output voltages on a common time scale.

e) Connect the circuit of Fig(3b) and repeat parts (a) through(d).

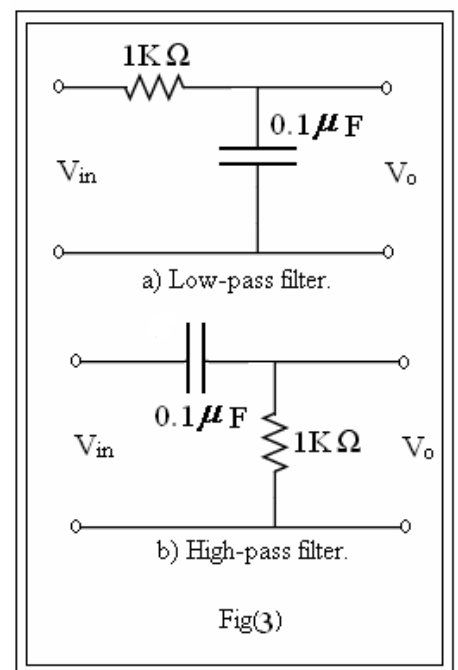

Analysis of results

a) Draw the attenuation factor A as a function of frequency for both the high and low pass filters. From the graphs find the value of ω_{-3dB} for both filters and compare it with the expected value.

b) Prove that the wave functions obtained in part (d) are the derivatives (in the case of the high pass filter) and integrals (in the case of the low pass filter) of the respective input functions.











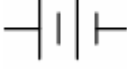

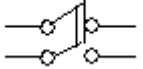
c) What is the phase relation between the input and the output voltages in both the unattenuated and the highly attenuated regions in both filters?

APPENDICES

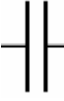
APPENDIX A

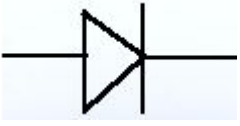
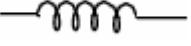
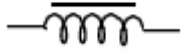
COMPONENTS OF ELECTRICAL CIRCUITS

The following is a list of the symbols most frequently used in schematic diagrams of electrical circuits:

Cell or Battery		
Switches		
Fuse		
Resistor (fixed)		
Resistor (variable)		
Capacitor		
Capacitor (variable)		
Diode		
Inductor (coil)		
Inductor (iron core)		
Ammeter		
Voltmeter		
AC supply		

Resistors are the most widely used of all electrical components. They are of many types and are very easy to use. The most common of these are carbon resistors. They differ in value and power rating; ¼ watts and ½ watts being the most popular types. Carbon resistors, however, are not very precise. They have, at best, tolerances of 50%. Hence, wire wound resistors are used in applications that require precision down to 1%.

Fig(2) shows a carbon resistor with the shaded regions representing the color bands used to read the value of the resistor. Given in the table in Fig(2) is the color code for the bands. To read the value of a resistor, start from the bands marked 1st digit and 2nd digit in Fig(2), decode their respective colors then multiply by the value corresponding to the color of the multiplier. The last band, marked tolerance, gives the error as a percentage of the marked value.

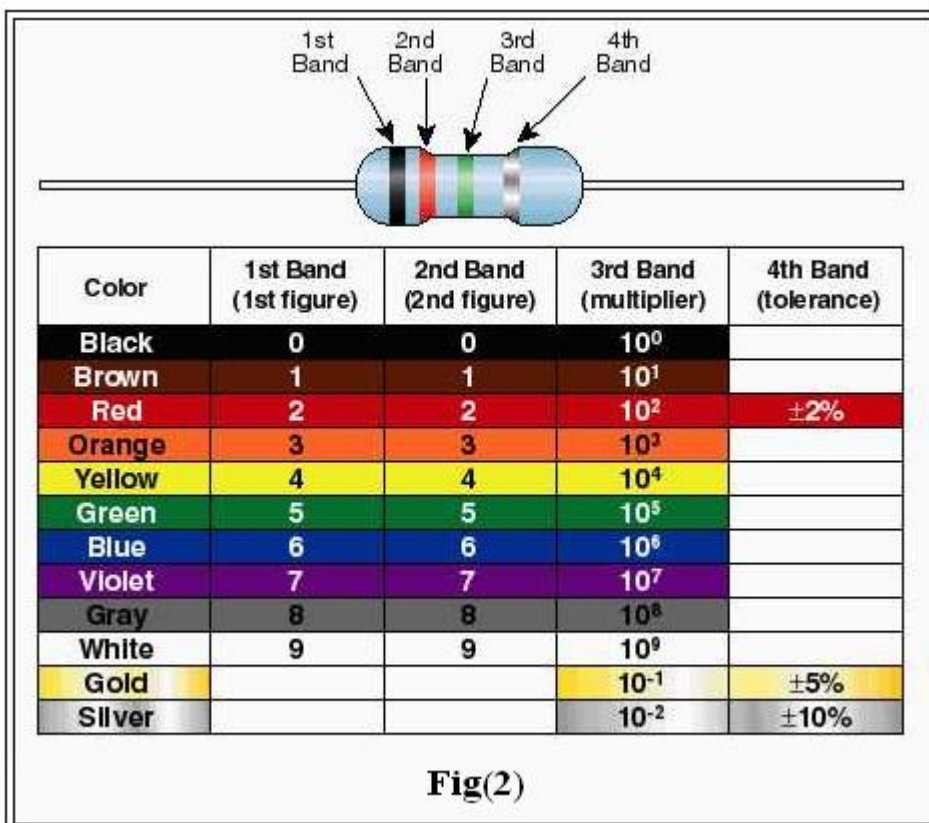

Hint: Here is an easy way to remember the code. Take the first letters from the words in the following sentence:

"Be Brave, Run Onto Your Goals, Because Victory Grants Wisdom"

Then assign them values 0 through 9 making them correspond to:

"Black Brown, Red, Orange, Yellow, Green, Blue, Violet, Gray, White"

APPENDIX B

SECOND ORDER LINEAR DIFFERENTIAL EQUATIONS WITH CONSTANT COEFFICIENTS

In the theory of circuit analysis, as in many other areas of physics, one often encounters equations of the form:

$$(1) a \frac{d^2y}{dx^2} + b \frac{dy}{dx} + cy = f(x)$$

Where a, b and c are real constants and f(x) is a function of x only. This equation is called a second order linear differential inhomogeneous equation. When f(x) = 0, the equation is called homogeneous, but as it stands it is called inhomogeneous. The general solution of this equation is the sum of the solution $y_h(x)$ of the homogeneous equation and a particular solution $y_p(x)$ of the full equation.

$$(2) y(x) = y_h(x) + y_p(x)$$

Let us start by looking at the homogeneous solution. The theory of differential equations requires that a second order differential equation must have two linearly independent solutions. The general solution $y_h(x)$ is a linear combination of these two solutions. $y_h(x)$ will contain two arbitrary constants that can be fixed after specifying boundary conditions.

As we are searching for a function that is proportional to its first and second derivatives, let us try

$$y_h(x) = e^{\lambda x},$$

where λ is a constant. Evaluating the derivatives:

$$\frac{dy_h}{dx} = \lambda e^{\lambda x}, \quad \frac{d^2y_h}{dx^2} = \lambda^2 e^{\lambda x}$$

and substituting back into equation(1) with f(x) = 0 we obtain:

$$a\lambda^2 e^{\lambda x} + b\lambda e^{\lambda x} + ce^{\lambda x} = 0.$$

After eliminating the exponential term we are left with the following second order algebraic equation:

$$(3) \quad a\lambda^2 + b\lambda + c = 0.$$

The solution of this equation is:

$$(4) \quad \lambda_{\pm} = \frac{-b}{2a} \pm \frac{1}{2a} \sqrt{b^2 - 4ac},$$

and hence,

$$(5) \quad y_h(x) = Ae^{\lambda_+x} + Be^{\lambda_-x},$$

where A and B are constants to be evaluated from boundary conditions.

The final functional dependence of $y_h(x)$ is specified by whether the quantity under the square root in equation(4) is positive, negative or zero:

- If $b^2 - 4ac > 0$, then both λ_+ and λ_- are negative real numbers and $y_h(x)$ is a linear combination of two exponentially decaying functions.
- If $b^2 - 4ac = 0$, then

$$\lambda_+ = \lambda_- = -\frac{b}{2a},$$

And the two solutions are identical. In order to get a linearly independent solution we resort to another result of the theory of differential equations which states that $xe^{\lambda x}$ could be combined with the original solution to get

$$y_h(x) = Ae^{\lambda x} + Be^{\lambda x}.$$

- If $b^2 - 4ac < 0$, then the term under the square root in equation(4) turns out to be imaginary. If we define

$$\omega' = \sqrt{\frac{c}{a} - \left(\frac{b}{2a}\right)^2},$$

then,

$$\lambda_+ = -\frac{b}{2a} + j\omega',$$

and

$$\lambda_- = -\frac{b}{2a} - j\omega',$$

The solution $y_h(x)$ takes the following form,

$$y_h(x) = Ae^{\lambda_+x} + Be^{\lambda_-x},$$

And after rearrangement it becomes

$$y_h(x) = Ce^{-\frac{b}{2a}x} \cos(\omega't + \Phi),$$

where C and Φ are constants.

The general solution to equation(1) has to incorporate also the particular solution corresponding to $f(x)$. This is generally taken to have the same functional dependence as $f(x)$. For example if $f(x) = E$, a constant, then we have to set

$$y_p(x) = F,$$

where F is constant. If we substitute in equation(1) we get

$$F = \frac{E}{c},$$

The general solution to equation(1), in this case, will be:

$$y_h(x) = Ae^{\lambda_+x} + Be^{\lambda_-x} + \frac{E}{c}.$$

Now, for $f(x) = A\cos(\omega x)$, where A and ω are constants and using

$$A\cos(\omega x) = \text{Re}(Ae^{j\omega x}),$$

we can work the solution using the complex representation as follows:

Let

$$y_p(x) = y_0 e^{j\omega x}$$

hence,

$$\frac{dy_p}{dx} = j\omega y_0 e^{j\omega x},$$

and

$$\frac{d^2 y_p}{dx^2} = -\omega^2 y_0 e^{j\omega x}.$$

Substituting in equation(1)

$$a(-\omega^2 y_0 e^{j\omega x}) + b(j\omega y_0 e^{j\omega x}) + c(y_0 e^{j\omega x}) = A e^{j\omega x}.$$

and after simplifying we get

$$y_0 = \frac{A}{(-a\omega^2 + c) + j\omega b}.$$

This is the complex amplitude. When transformed into the polar representation, y_0 appears as:

$$y_0 = \frac{A e^{j\Phi}}{\sqrt{(c - \omega^2 a)^2 + \omega^2 b^2}},$$

where,

$$\Phi = \tan^{-1}\left(\frac{\omega b}{a\omega^2 - b}\right).$$

We need the real part of the solution, i.e.

$$y_p(x) = \text{Re}(y_0 e^{j\omega x}).$$

Evaluating the real part gives:

$$y_p(x) = y_0 \cos(\omega x + \Phi),$$

where,

$$y_0 = \frac{A}{\sqrt{(c - \omega^2 a^2) + \omega^2 b^2}}.$$

Finally, the general solution is the sum of the homogeneous and the particular solutions:

$$y(x) = C e^{\lambda_+ x} + B e^{\lambda_- x} + y_0 \cos(\omega x + \Phi).$$

where C and B are constants to be determined from the boundary or initial conditions.

APPENDIX C

COMPLEX NUMBERS

A complex number is defined as a point in the complex plane, see Fig(1). A complex number can be represented in two general forms:

The Component Form:

Any complex number could be represented by:

$$Z = R + jX,$$

where Z is a complex number, R is its real part ($R = \text{Re}(Z)$), X is its imaginary part

($X = \text{Im}(Z)$) and $j = \sqrt{-1}$

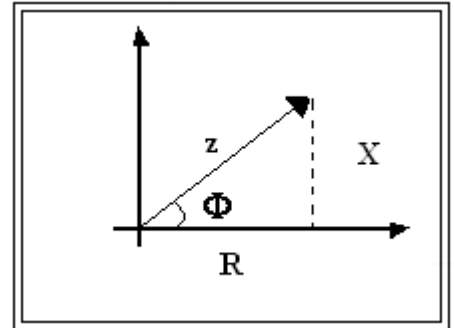

The Polar Form:

Another way to represent a complex number is

$$Z = z e^{j\Phi},$$

where z is the modulus of Z and Φ is its argument.

It should be obvious from Fig(1) that

$$z = \sqrt{R^2 + X^2},$$

and

$$\Phi = \tan^{-1}\left(\frac{X}{R}\right).$$

Euler's Formula

The following is termed Euler's formula after "Leonhard Euler" who developed it

$$e^{j\Phi} = \cos(\Phi) + j \sin(\Phi),$$

Identifying the left hand side as a complex number written in the polar form and the right hand side as the same number written in the component form, one could write:

$$\cos(\Phi) = \text{Re}(e^{j\Phi}),$$

and

$$\sin(\Phi) = \text{Im}(e^{j\Phi}).$$

Therefore, instead of dealing with trigonometric functions, one can perform the work with complex numbers in the polar form and then take either its real or imaginary part as the physical solution.

Important Properties of Complex Numbers

If $Z_1 = R_1 + jX_1$ and $Z_2 = R_2 + jX_2$ are complex numbers then,

- **Equality of two complex numbers**

$$Z_1 = Z_2 \text{ if and only if } R_1 = R_2 \text{ and } X_1 = X_2.$$

- **Addition and subtraction of complex numbers**

$$Z_1 \pm Z_2 = (R_1 \pm R_2) + j(X_1 \pm X_2).$$

- **Multiplying and division of complex numbers**

Multiplication and division of complex numbers are better performed using the polar form:

$$Z_1 Z_2 = z_1 z_2 e^{j(\Phi_1 + \Phi_2)},$$

and

$$\frac{Z_1}{Z_2} = \frac{z_1}{z_2} e^{j(\Phi_1 - \Phi_2)}.$$

- **Rationalizing a complex number**

A complex number Z is rationalized through multiplying it by its conjugate Z^* . Z^* is found by multiplying the imaginary part of Z by -1 . This operation is useful when a complex number appears in the denominator.

Example:

To rationalize the complex number $Z = 1/(R + jX)$ we multiply both the nominator and the denominator by the conjugate of the complex number appearing in the denominator:

$$Z = \frac{1}{R + jX} \left(\frac{R - jX}{R - jX} \right) = \frac{R - jX}{R^2 + X^2}$$

Therefore, the complex number Z takes the following simple component form:

$$Z = \frac{R}{R^2 + X^2} - j \frac{X}{R^2 + X^2}$$

Analyzing an RLC Circuit Using complex impedance

The current passing through an AC-driven series RLC circuit is found through the generalized Ohm's law to be:

$$(1) \quad I(t) = \frac{\varepsilon(t)}{Z_{eq}},$$

where the source emf, $\varepsilon(t) = \varepsilon_0 \cos(\omega t)$, can be represented in its complex form as

$$\varepsilon(t) = \varepsilon_0 e^{j\omega t},$$

and

$$Z_{eq} = R + j\omega L - \frac{j}{\omega C},$$

or

$$Z_{eq} = R + j\left(\omega L - \frac{1}{\omega C}\right)$$

Substituting for $\varepsilon(t)$ and Z_{eq} in equation(1) we get:

$$I(t) = \frac{\varepsilon_0 e^{j\omega t}}{R + j\left(\omega L - \frac{1}{\omega C}\right)}.$$

To rationalize, we multiply both numerator and denominator or by the conjugate

$$I(t) = \frac{\varepsilon_0 e^{j\omega t}}{R + j\left(\omega L - \frac{1}{\omega C}\right)} \left(\frac{R - j\left(\omega L - \frac{1}{\omega C}\right)}{R - j\left(\omega L - \frac{1}{\omega C}\right)} \right).$$

On rearrangement we get:

$$I(t) = \frac{\left(R - j\left(\omega L - \frac{1}{\omega C}\right)\right) \varepsilon_0 e^{j\omega t}}{R^2 + \left(\omega L - \frac{1}{\omega C}\right)^2}.$$

Transforming the complex number $R - j(\omega L - \frac{1}{\omega C})$ into its polar form we get:

$$I(t) = \frac{\sqrt{R^2 + (\omega L - \frac{1}{\omega C})^2} \varepsilon_0 e^{j(\omega t + \Phi)}}{R^2 + (\omega L - \frac{1}{\omega C})^2},$$

And on simplification we get:

$$I(t) = \frac{\varepsilon_0}{\sqrt{R^2 + (\omega L - \frac{1}{\omega C})^2}} e^{j(\omega t + \Phi)}$$