

Negative Feedback

Negative Feedback

Advantages

- 1-Stabilizes the gain of the amplifier against parameters changes in the active devices due to temperature .
- 2- Modifies the input and output impedance in any desired fashion.
- 3- Increases the Bandwidth .

Disadvantages

- 1- Decreases the gain .
- 2- Oscillation .

Negative Feedback

General Feedback equation

$$S_o = AS_e$$

$$S_e = S_i - S_{fb}$$

$$A_f = \frac{S_o}{S_i} = \frac{A}{1+AB}$$

$AB \equiv$ Loop gain

If $AB \gg 1$

$$\therefore A_f = \frac{1}{B}$$

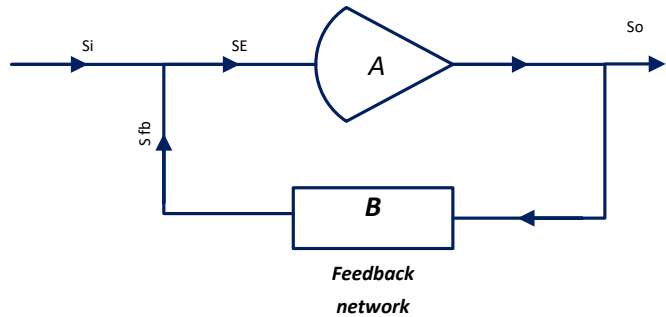

Negative Feedback

General Feedback equation

$$S_e = S_i - S_{fb}$$

$$S_e = S_i - BS_o$$

$$S_e = S_i - B \frac{A}{1+AB} S_i$$

$$S_e = S_i \left(1 - \frac{AB}{1+AB}\right)$$

If $AB \gg 1$

$$S_e \approx S_i \left(1 - \frac{AB}{AB}\right) \approx 0$$

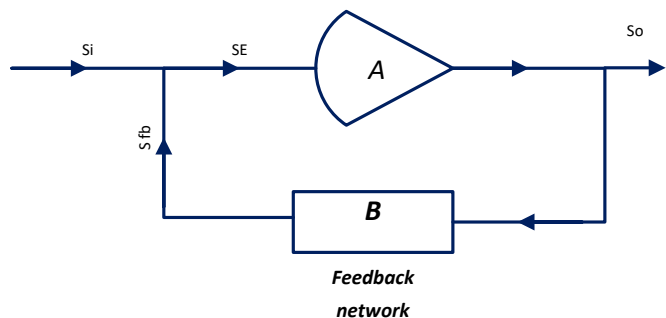

Negative Feedback

Gain stabilization

let $A = 10,000$

$B = 0.01$

$\therefore AB = 100$

$$Af = \frac{A}{1 + AB} = 99$$

let $A = 9000$

$B = 0.01$

$\therefore AB = 90$

$$Af = \frac{A}{1 + AB} = 98.9$$

Change in A → change in Af

10% → 0.1%

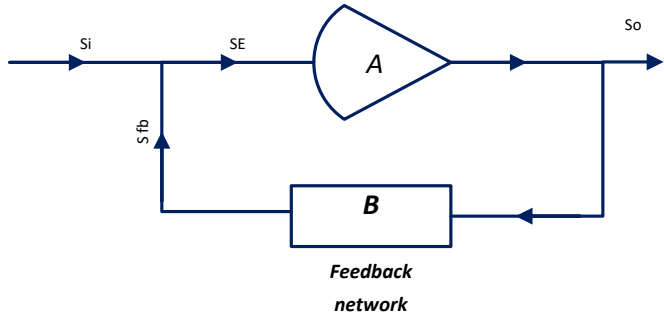

Negative Feedback

Increasing the Bandwidth.

In high frequency

$$A(j\omega) = \frac{Am}{1 + \frac{j\omega}{\omega_2}}$$

$\therefore \omega_H = \omega_2$

With Negative Feedback

$$Af(j\omega) = \frac{Am}{1 + AmB} = \frac{1}{1 + \frac{j\omega}{\omega_2(1 + AmB)}}$$

$\therefore \omega_H = \omega_2(1 + AmB)$

Types Of Negative Feedback

1) Series – Shunt Feedback

$$V_o = A V_e$$

$$V_e = V_i - V_{fb}$$

$$V_{fb} = B V_o$$

$$\therefore \frac{V_o}{V_i} = \frac{A}{1 + AB} = A_f$$

$$Z_{if} = \frac{v_i}{i_i}$$

$$\begin{aligned} V_i &= V_e + V_{fb} \\ &= R_i i_i + B V_o \\ &= R_i i_i + B A V_e \\ &= R_i i_i + B A R_i i_i \end{aligned}$$

$$\therefore Z_{if} = \frac{V_i}{i_i} = R_i(1 + AB)$$

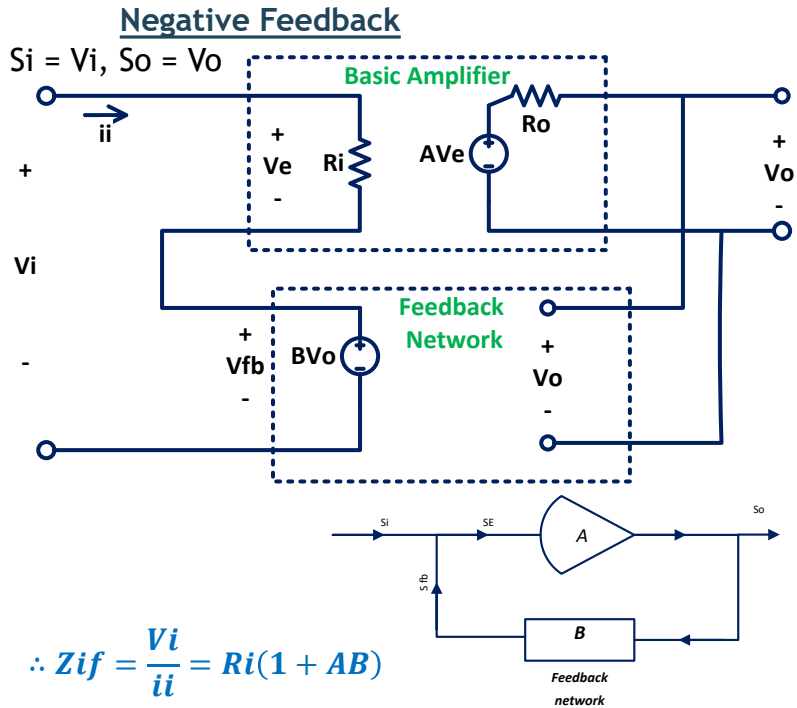

1) Series – Shunt Feedback

$$Z_{of} = \left. \frac{V_x}{i_x} \right|_{v_i = 0}$$

$$i_x = \frac{V_x - A V_e}{R_o}$$

$$V_e = -B V_x$$

$$i_x = \frac{V_x + AB V_x}{R_o}$$

$$\therefore \frac{V_x}{i_x} = \frac{R_o}{1 + AB}$$

Negative Feedback

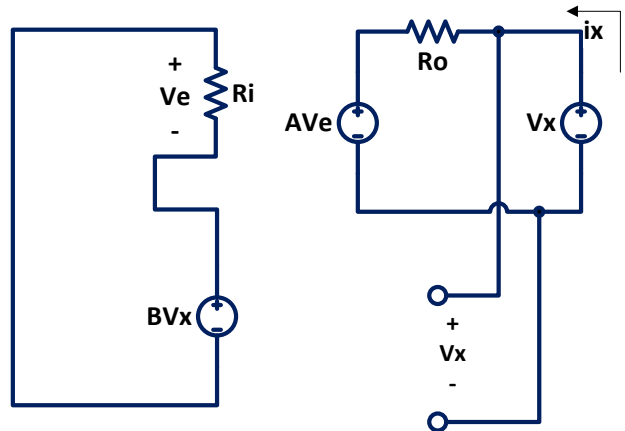

Series Feedback at the input always raises the input impedance by (1+AB)

shunt Feedback at the output always lowers the output impedance by (1+AB)

Negative Feedback

1) Series – Shunt Feedback

Equivalent ckt of Series - shunt amplifier

$$Z_{if} = (1+AB) R_i$$

$$Z_{of} = \frac{R_o}{1 + AB}$$

$$A_f = \frac{A}{1 + AB} = \frac{V_o}{V_i}$$

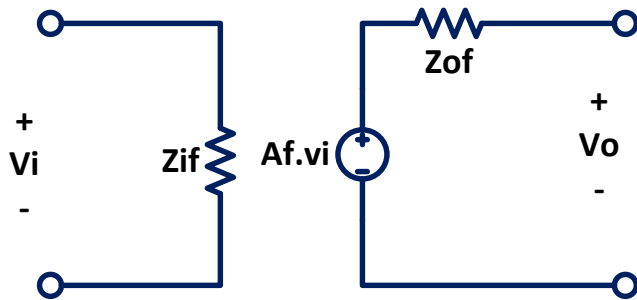

1) Series – Shunt Feedback

Negative Feedback

Equivalent ckt of Series shunt amplifier

If $A \rightarrow \infty$;

$$Z_{if} = \infty ;$$

$$Z_{of} = 0 ;$$

$$A_f = \frac{1}{B}$$

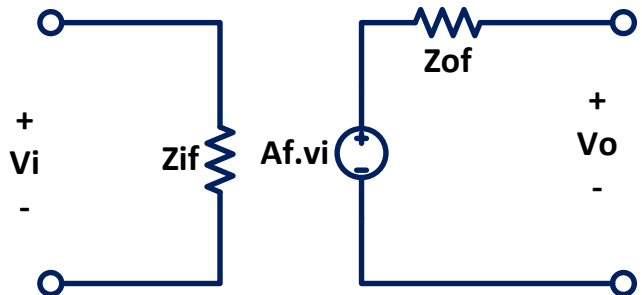

$$Z_{if} = (1+AB) R_i$$

$$Z_{of} = \frac{R_o}{1 + AB}$$

$$A_f = \frac{A}{1 + AB} = \frac{V_o}{V_i}$$

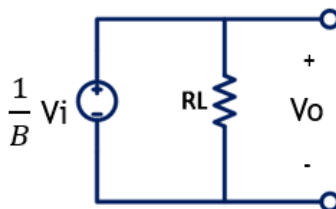
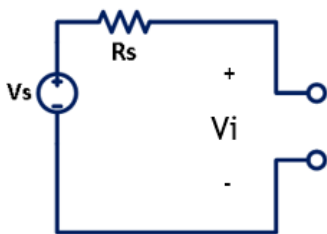

Negative Feedback

1) Series - Shunt Feedback

Equivalent ckt of Series shunt amplifier

If we have R_s and R_L

$$V_o = \frac{1}{B} V_i$$

$$V_i = V_s$$

$$\therefore \frac{V_o}{V_s} = \frac{1}{B}$$

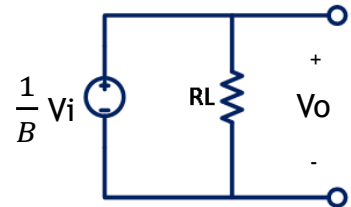
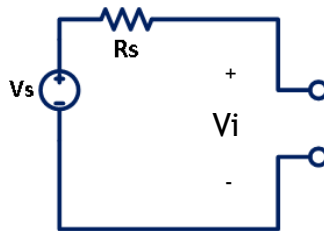

2) Shunt - Shunt Feedback

Negative Feedback

$S_i = i_i$, $S_o = V_o$

$$V_o = A i_e$$

$$i_e = i_i - i_{fb}$$

$$i_{fb} = B V_o$$

$$V_o = A(i_i - B V_o)$$

$$\therefore \frac{V_o}{i_i} = A_f = \frac{A}{1 + AB}$$

$$A = \frac{V_o}{i_e}$$

$$B = \frac{i_{fb}}{V_o}$$

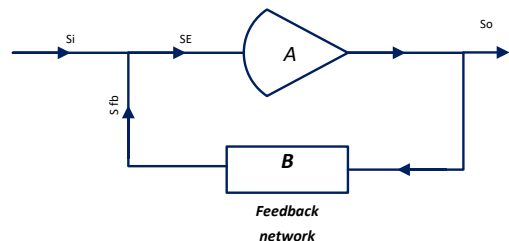
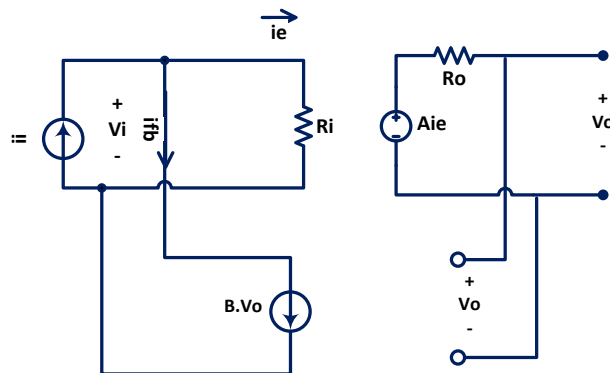

AB is dimensionless

2) Shunt - Shunt Feedback

Negative Feedback

The input impedance

$$Z_{if} = \frac{V_i}{i_i}$$

$$V_i = R_i i_e$$

$$i_e = i_i - i_{fb}$$

$$i_{fb} = B V_o$$

$$V_o = \frac{A}{1 + AB} i_i$$

$$\therefore Z_{if} = \frac{R_i}{1 + AB}$$

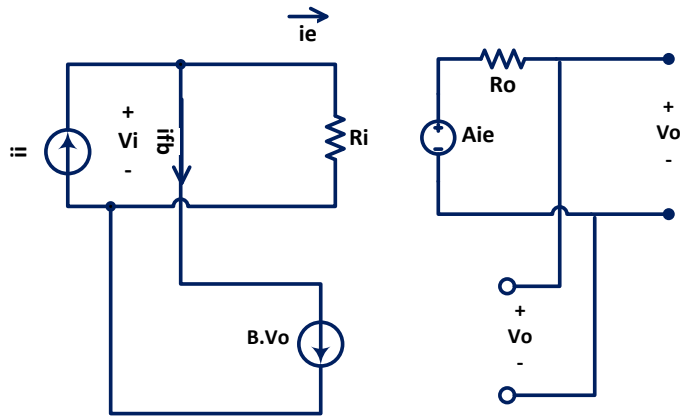

The output impedance

▶ it is easy to show

$$Z_{of} = \frac{R_o}{1 + AB}$$

▶ using :

$$Z_{of} = \left. \frac{V_t}{i_t} \right|_{i_i = 0}$$

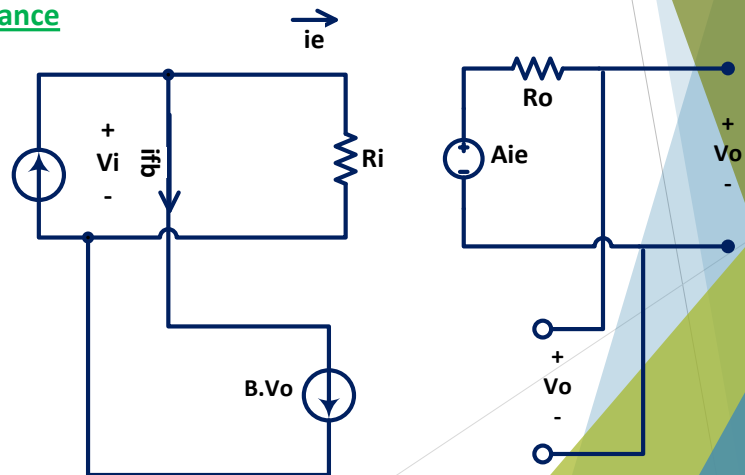

Negative Feedback

2) Shunt - Shunt Feedback

Equivalent ckt of Shunt Shunt amplifier

If $A \rightarrow \infty$;

$Z_{if} = 0$;

$Z_{of} = 0$;

$A_f = \frac{1}{B}$

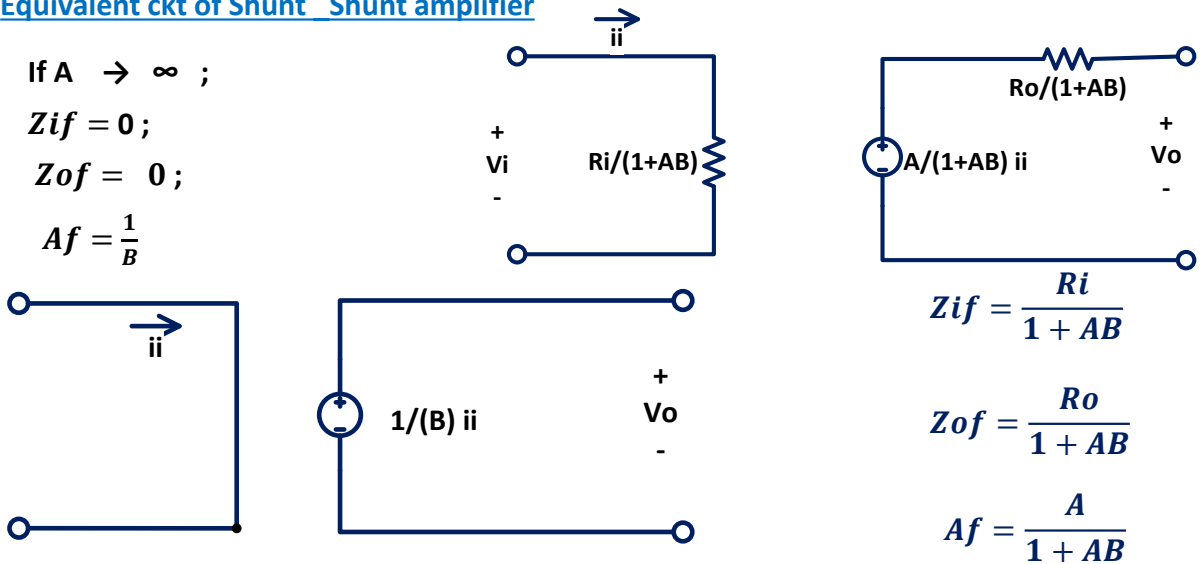

Negative Feedback

2) Shunt - Shunt Feedback

Equivalent ckt of Shunt Shunt amplifier

If we have R_s and R_L

$V_o = \frac{1}{B} ii$

$ii = is$

$\frac{V_o}{is} = \frac{1}{B}$

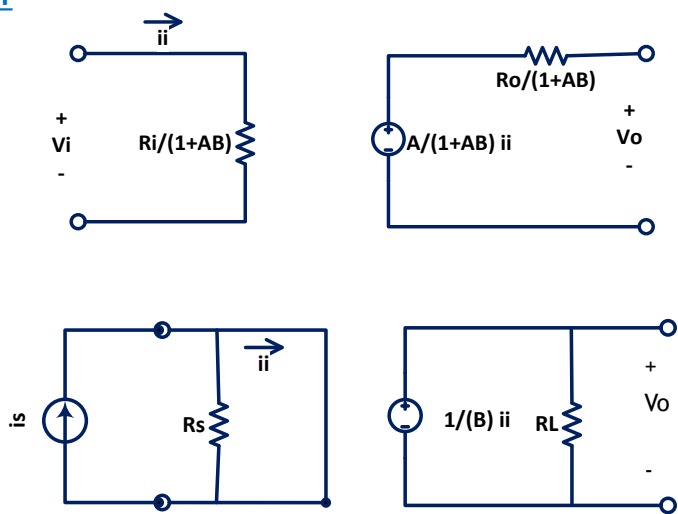

3) Shunt - Series Feedback

$$i_o = A i_e \frac{R_o}{R_o + Z_L}$$

if $Z_L \ll R_o$

$$i_o = A i_e$$

$$i_e = i_i - i_{fb}$$

$$i_{fb} = B i_o$$

$$\therefore \frac{i_o}{i_i} = A_f = \frac{A}{1 + AB}$$

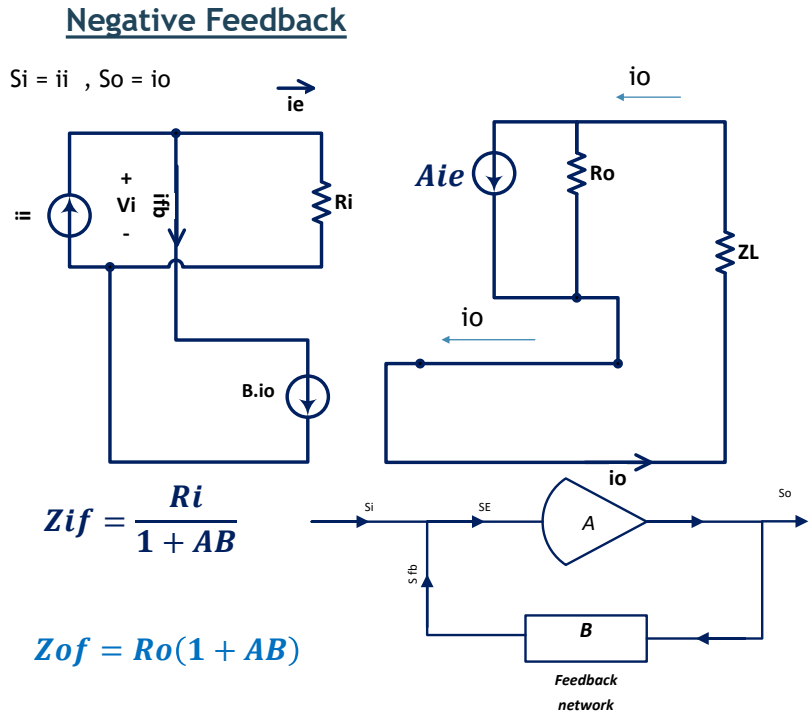

4) Series - Series Feedback

$S_i = V_i, S_o = i_o$

if $Z_L \ll R_o$

$$\frac{i_o}{V_i} = A_f = \frac{A}{1 + AB}$$

$$Z_{if} = R_i(1 + AB)$$

$$Z_{of} = R_o(1 + AB)$$

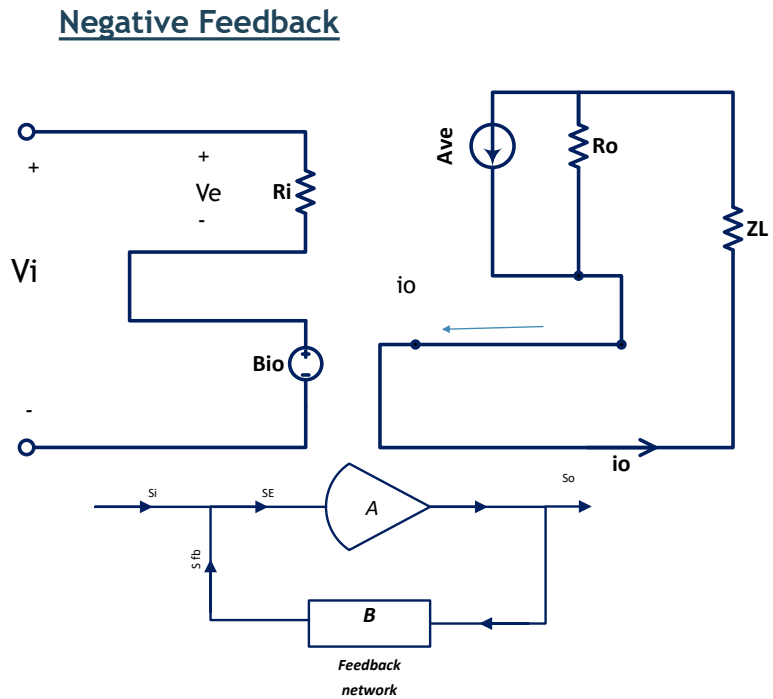

Negative Feedback

Practical configuration and the effect of loading

1) Shunt - Shunt Feedback

$$S_i = i_s$$

$$S_o = V_o$$

$$A_f = \frac{V_o}{i_s} = \frac{A}{1 + AB}$$

$$|Y_{12} a| \ll |Y_{12} f|$$

$$|Y_{21} a| \gg |Y_{21} f|$$

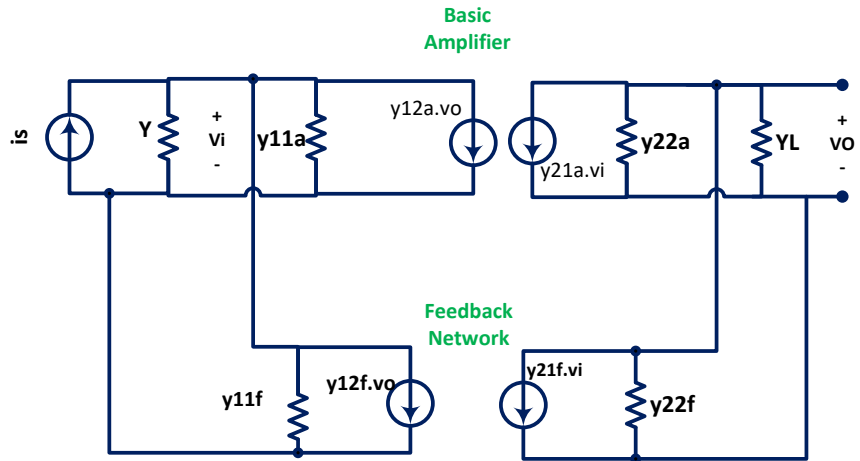

1) Shunt - Shunt Feedback

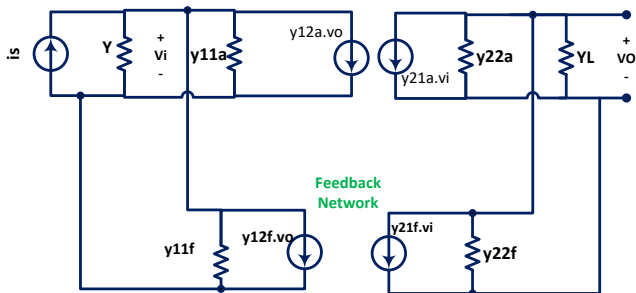

New basic amplifier =
basic amplifier + loading

New basic amplifier

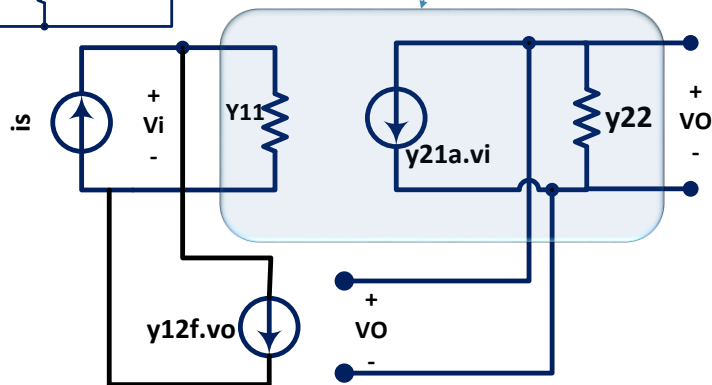

$$Y_{11} = y_{11} a + y_{11} f + Y$$

$$Y_{22} = y_{22} a + y_{22} f + Y_L$$

$$\therefore y_{12} f = B$$

Negative Feedback

Practical configuration and the effect of loading

1) Shunt - Shunt Feedback

Example:

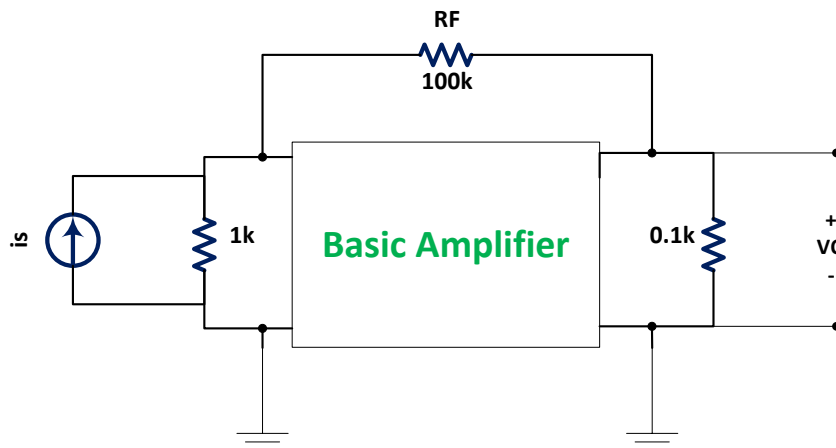

Negative Feedback

Practical configuration and the effect of loading

1) Shunt - Shunt Feedback

Example:

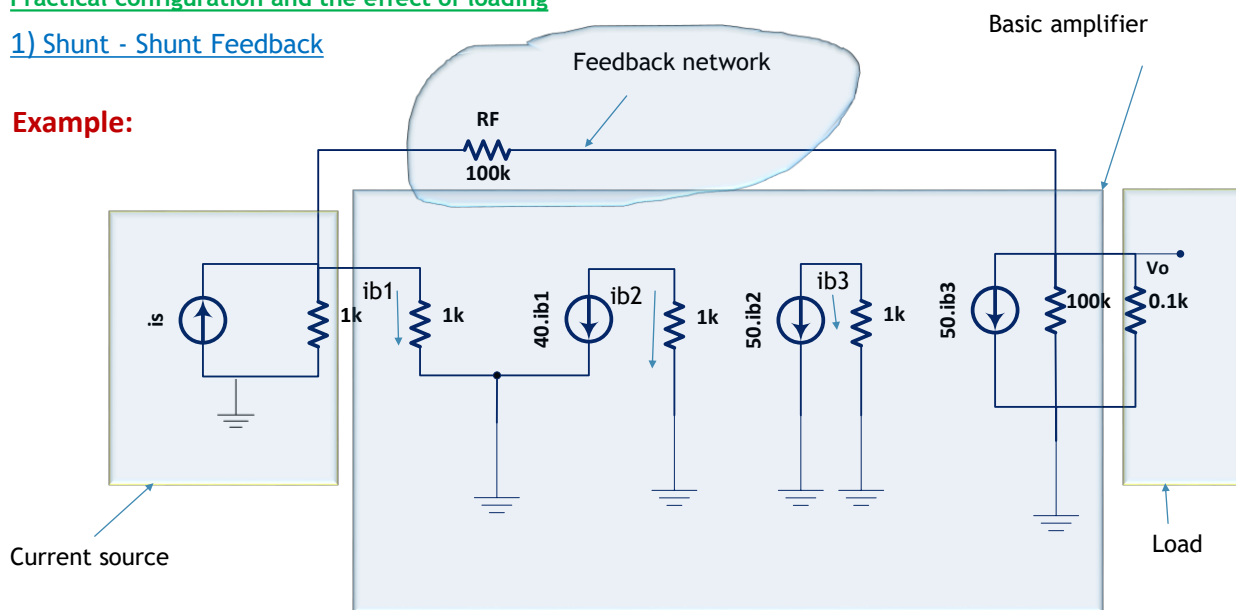

1) Shunt - Shunt Feedback

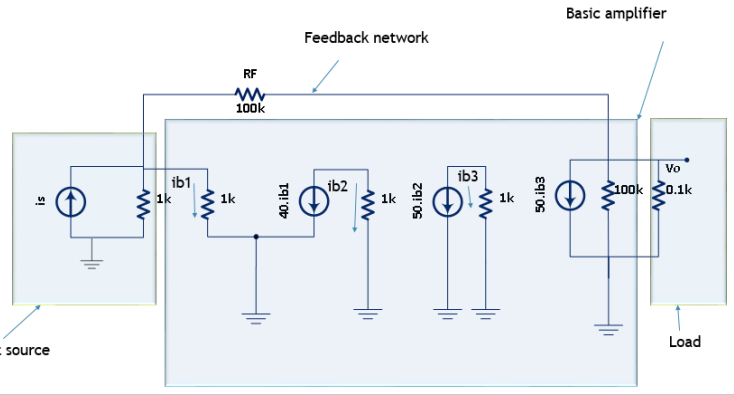

New Basic Amplifier: $A = \frac{V_o}{i_s}$

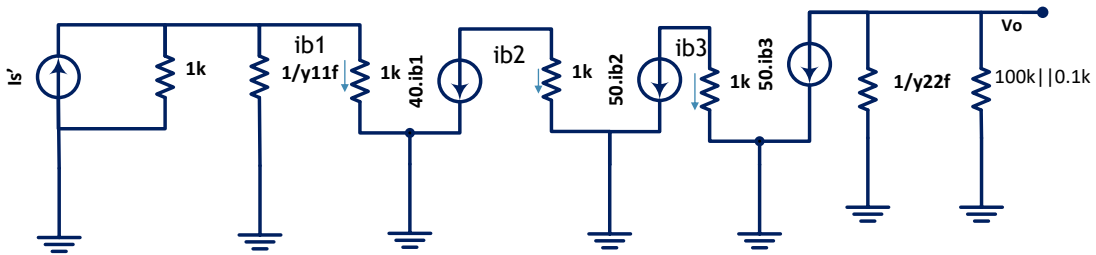

Negative Feedback

Practical configuration and the effect of loading

1) Shunt - Shunt Feedback

The Feedback network

$$y_{11} = \frac{1}{RF} = \frac{1}{100k}$$

$$y_{22} = \frac{1}{RF} = \frac{1}{100k}$$

$$y_{12} = \frac{-1}{RF} = \frac{-1}{100k}$$

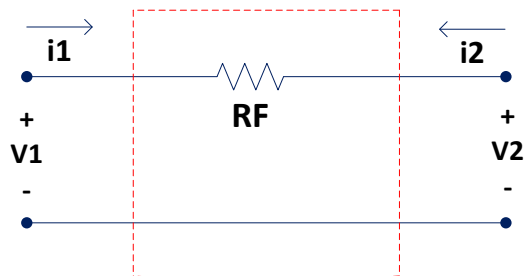

$B = y_{12} f$

Negative Feedback

1) Shunt - Shunt Feedback

To calculate A : New basic amplifier

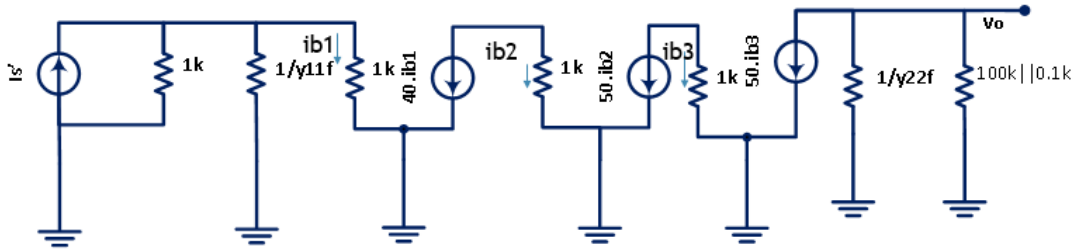

$$A = \frac{V_o}{i_s}$$

$$V_o = -50ib_3 \left(100k || 0.1k || \frac{1}{y_{22}f} \right)$$

$$ib_3 = -50ib_2$$

$$ib_2 = -40ib_1$$

$$ib_1 = i_s \frac{1k || \frac{1}{y_{11}f}}{1k || \frac{1}{y_{11}f} + 1k}$$

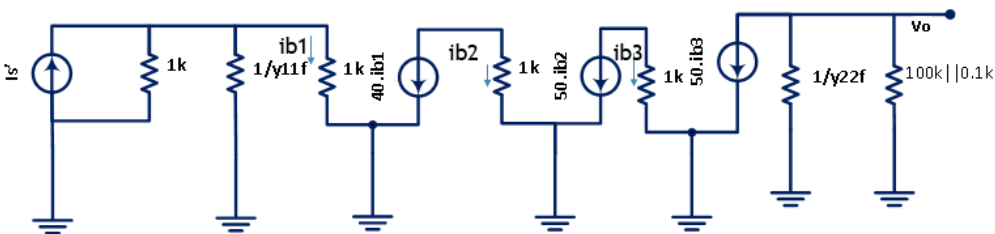

- ▶ $\therefore A = -4965 k \Omega$
- ▶ $B = -0.01 m\bar{U}$
- ▶ $AB = 49.65$
- ▶ $Af = \frac{V_o}{i_s} = \frac{A}{1+AB} = -98K \Omega$
- ▶ $\frac{1}{B} = -100k\Omega$

Negative Feedback

Practical configuration and the effect of loading

1) Shunt - Shunt Feedback

Example: Inverting Amplifier

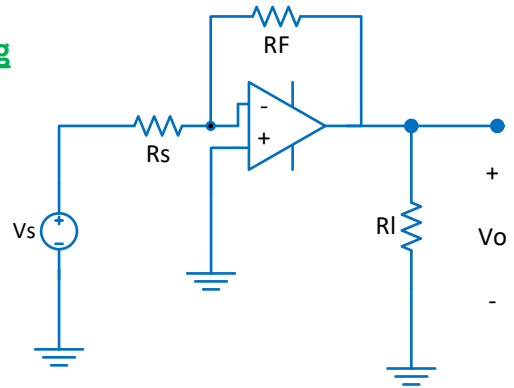
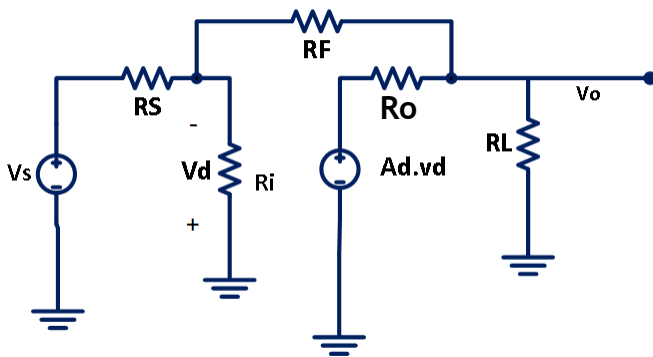

- $R_s = 100k\Omega$
- $R_f = 1M\Omega$
- $R_l = 10k\Omega$
- $R_o = 75\Omega$
- $R_i = 2M\Omega$
- $Ad = 200,000$

Negative Feedback

Practical configuration and the effect of loading

1) Shunt - Shunt Feedback

The Feed-Back Network:

$$y_{11f} = \frac{1}{R_F};$$

$$y_{22f} = \frac{1}{R_F}$$

$$y_{12f} = -\frac{1}{R_F} = \beta$$

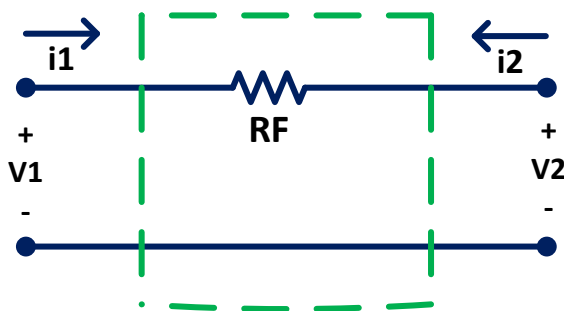

Practical configuration and the effect of loa

1) Shunt - Shunt Feedback

New Basic Amplifier : $A = \frac{V_o}{i_s}$

$$V_o = \frac{R_L || \frac{1}{y_{22f}}}{R_L || \frac{1}{y_{22f}} + R_o} AdV_d$$

$$V_d = -i_s'(R_s || \frac{1}{y_{11f}} || R_i)$$

$$A = \frac{V_o}{i_s} = -1.726 \times 10^{10}$$

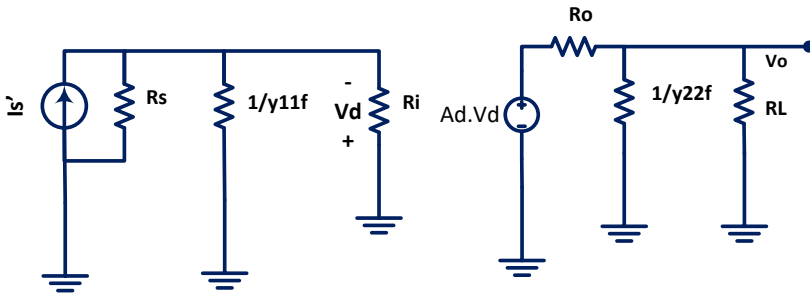
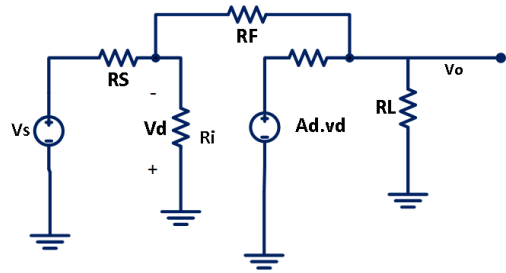

To find $A_v = \frac{V_o}{V_s}$

$$\frac{V_o}{V_s} = \frac{V_o}{i_s} \cdot \frac{i_s}{V_s} = A_f \cdot \frac{1}{R_s}$$

$$A_v = -9.9994$$

If the Op.amp is ideal

$$A_v = -\frac{R_F}{R_S} = -10$$

$$B = \frac{-1}{R_F} = -1 \times 10^{-6}$$

$$AB = 17260$$

$$A_f = \frac{V_o}{i_s} = \frac{A}{1 + AB} = -999.94k \Omega$$

Negative Feedback

Practical configuration and the effect of loading

2) Series - Shunt Feedback

$$V1 = h11i1 + h12V2$$

$$i2 = h21i1 + h22V2$$

$$|h12_a| \ll |h12_f|;$$

$$|h21_a| \gg |h21_f|;$$

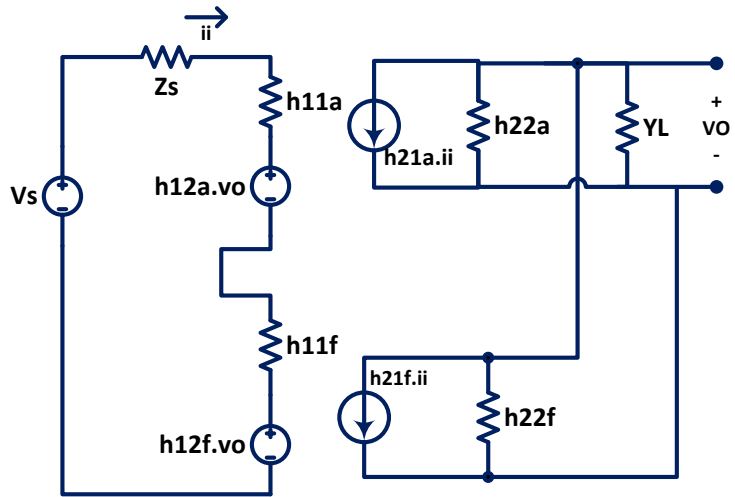

2) Series - Shunt Feedback

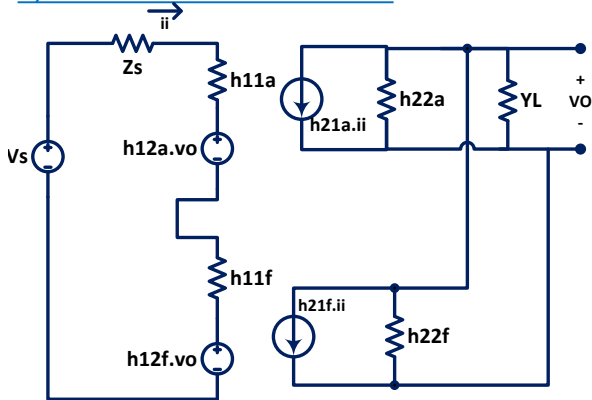

The new basic amplifier

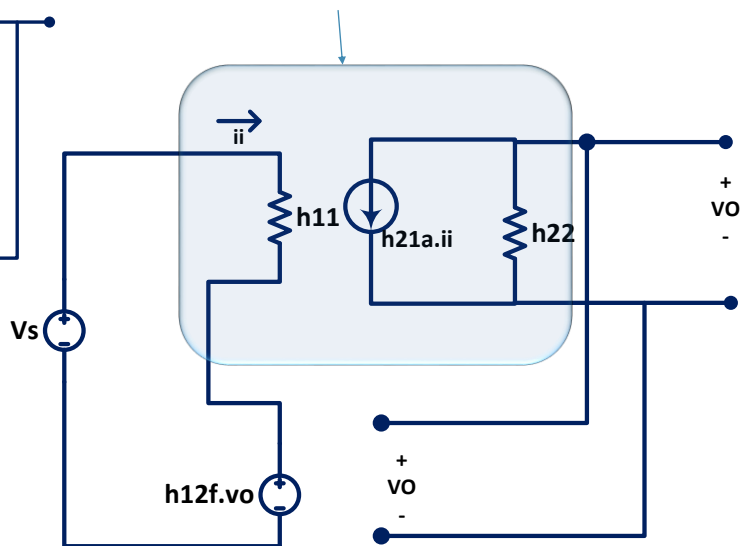

$$B = h12_f;$$

$$Af = \frac{Vo}{Vs} = \frac{A}{1 + AB}$$

Negative Feedback

Practical configuration and the effect of loading

2) Series - Shunt Feedback

Example:

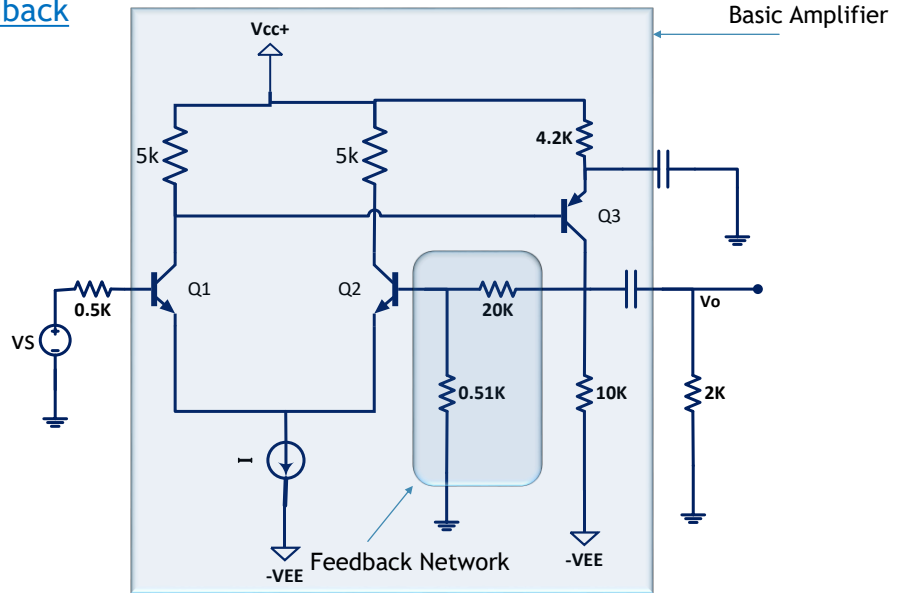

Negative Feedback

Practical configuration and the effect of loading

2) Series - Shunt Feedback

Example:

The Feed-Back Network:

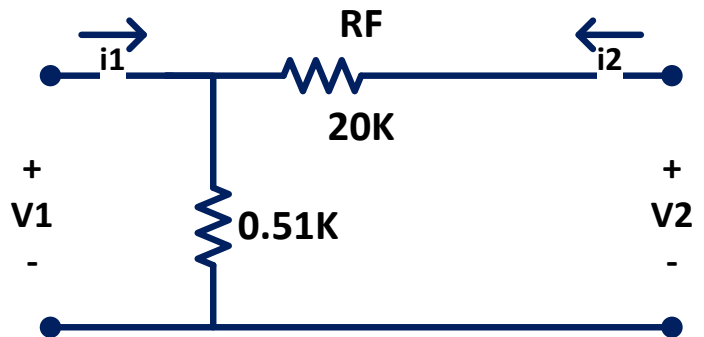

$$h_{11f} = 0.51 || 20k$$

$$h_{22f} = \frac{1}{20k + 0.51k}$$

$$h_{12f} = \frac{0.51k}{0.51k + 20k} = B$$

Practical configuration and the effect of loading

2) Series - Shunt Feedback

New Basic Amplifier : $A = \frac{V_o}{V_s}$

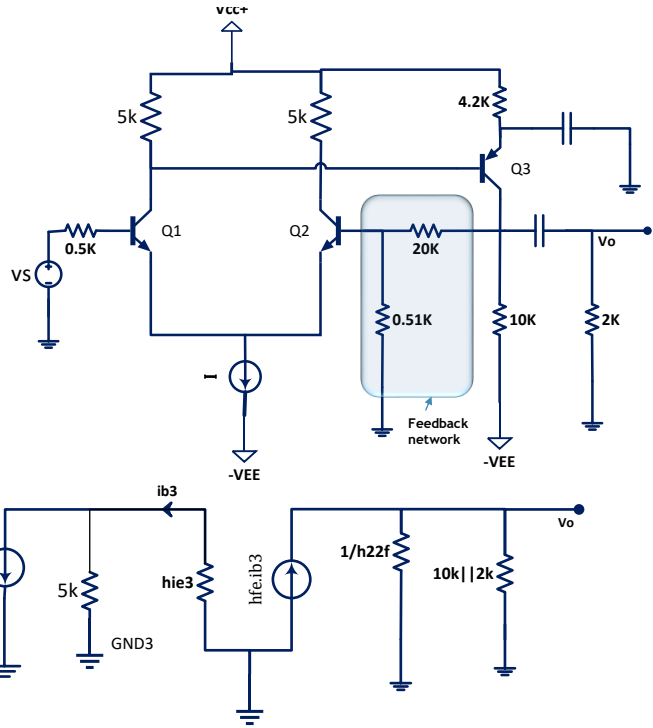
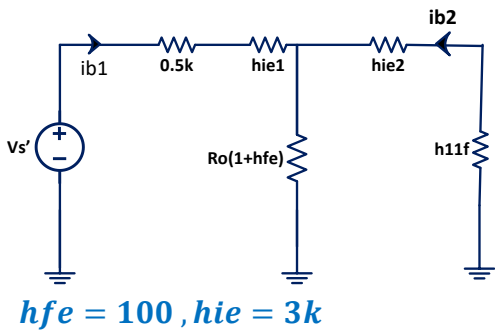

Negative Feedback

Practical configuration and the effect of loading

2) Series - Shunt Feedback

Differential Mode Analysis:

$$V_o = hfe \, ib_3 \left(\frac{1}{h_{22f}} \parallel 10k \parallel 2k \right)$$

$$ib_3 = hfe \, ib_1 \frac{5k}{5k + 3k}$$

$$ib_1 = -ib_2$$

$$ib_1 = \frac{V_s}{0.5k + hie_1 + hie_2 + h_{11f}}$$

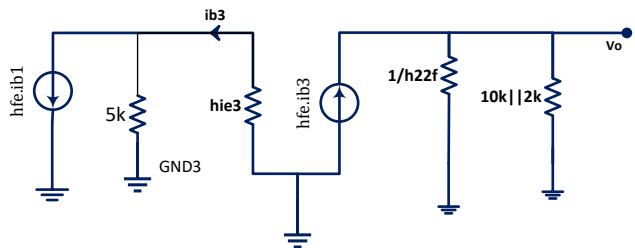
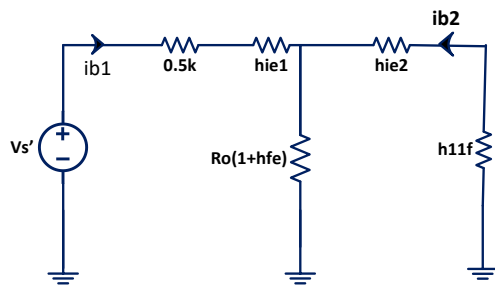

▶ $A = \frac{V_o}{V_s} = 1379$

▶ $AB = 34.3$

▶ $A_f = \frac{V_o}{V_s} = \frac{A}{1+AB} = 39$

▶ $\frac{1}{B} = 40.2$

2) Series - Shunt Feedback

Example: Non-Inverting Amplifier

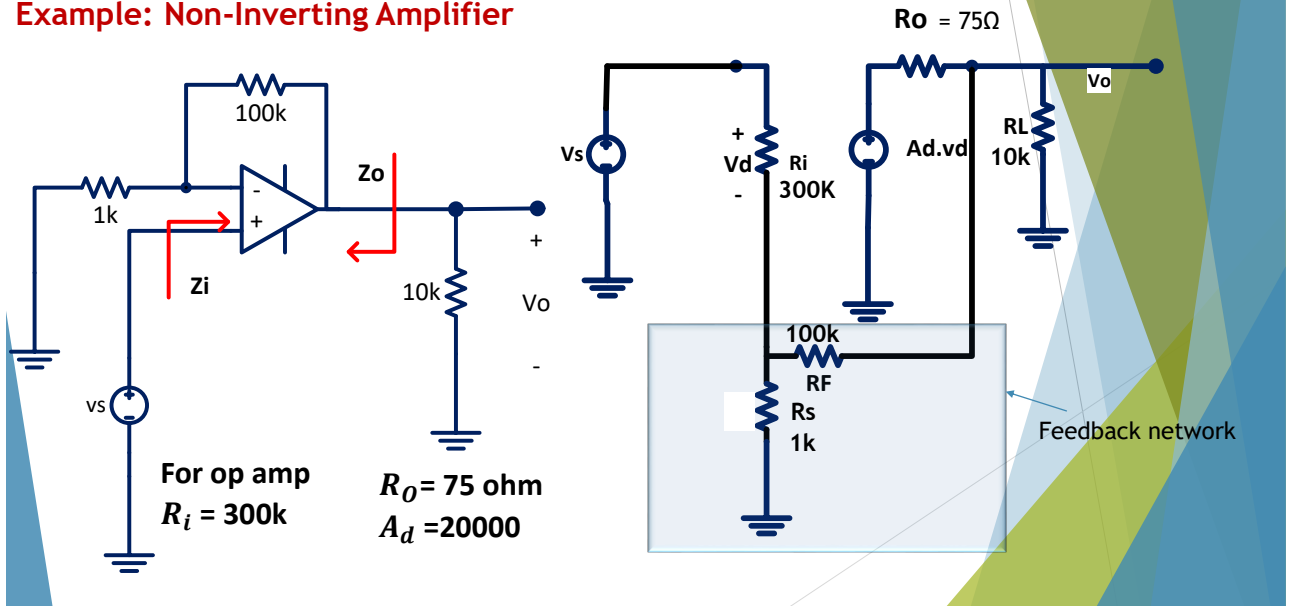

Negative Feedback

Practical configuration and the effect of loading

2) Series - Shunt Feedback

Example: Non-Inverting Am

The Feed-Back Network:

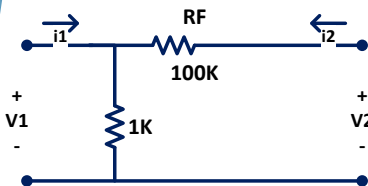

$$h_{11f} = 100k || 1k$$

$$h_{22f} = \frac{1}{1k + 100k}$$

$$h_{12f} = \frac{1}{1k + 100k} = B$$

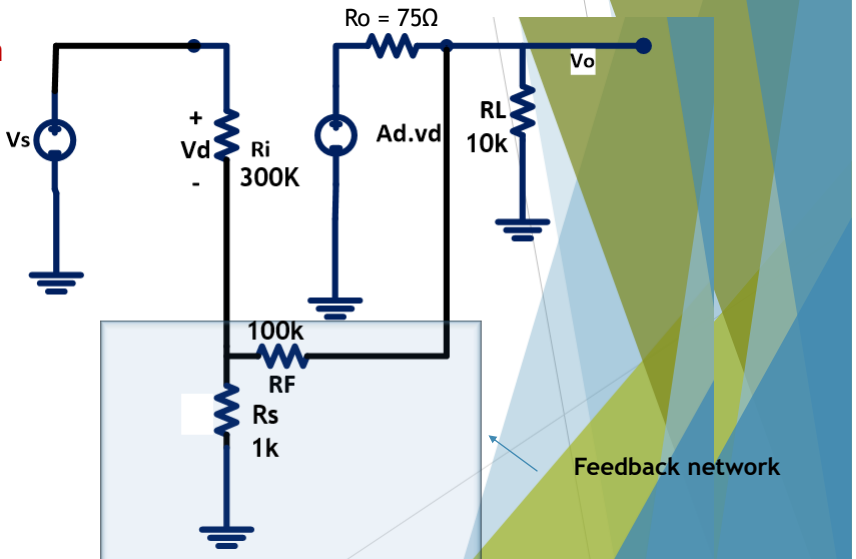

2) Series - Shunt Feedback

Example: Non-Inverting Amplifier

$$A = \frac{V_o}{V_s}$$

$$V_o = \frac{(10k || \frac{1}{h_{22f}})(20000 V_d)}{(10k || \frac{1}{h_{22f}}) + 75}$$

$$V_d = \frac{300k}{300k + h_{11f}} V_s$$

$$A = 19771$$

$$AB = 195.75$$

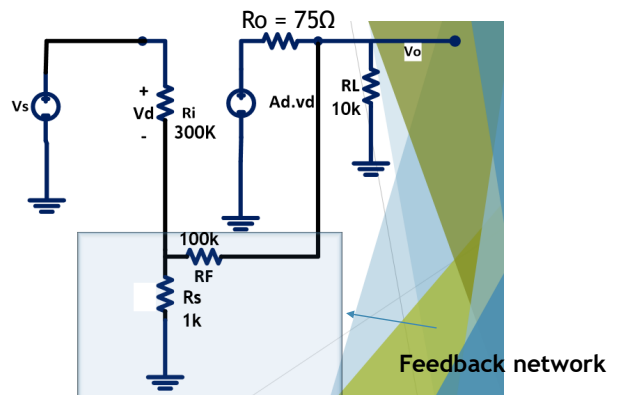

New Basic Amplifier :

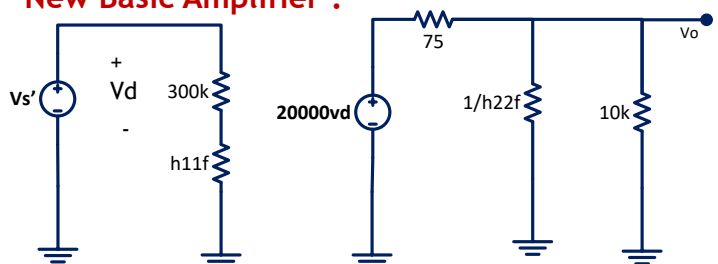

► $Af = \frac{V_o}{V_s} = \frac{A}{1+AB} = 100.487$

► $\frac{1}{B} = 101$

If the op amp is ideal $\therefore A_v = (1+R_f/R_s) = 101$

$Z_{if} = R_i(1 + AB);$

$R_i = 300k + h_{11f}$

$\therefore Z_{if} = 59.221M \Omega$

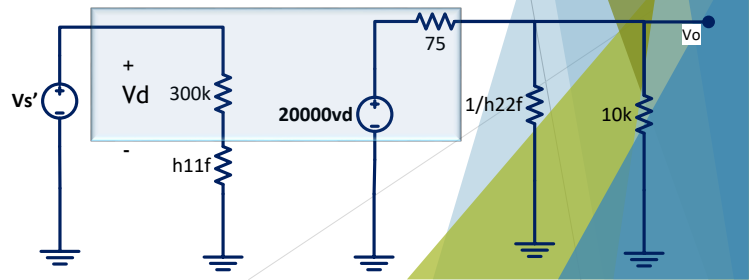

Negative Feedback

2) Series - Shunt Feedback

Example: Non-Inverting Amplifier

$Z_{of} = \frac{R_o}{1 + AB}$

$R_o = 10k || 101k || 75$

$R_o = 74.4 \Omega$

$\therefore Z_{of} = 0.377 \Omega$

$Z_{of} = Z_o || 10k$

$\therefore Z_o = 0.378 \Omega$

New Basic Amplifier

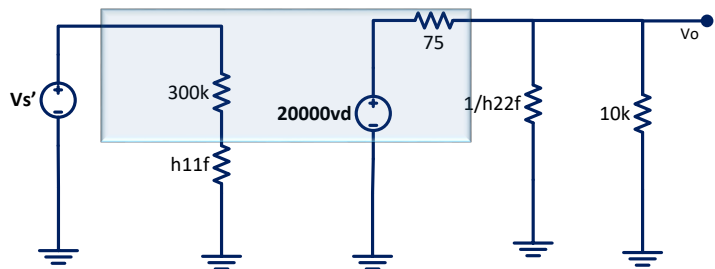

Negative Feedback

Practical configuration and the effect of loading

3) Shunt - Series Feedback

$$i_1 = g_{11}V_1 + g_{12}i_2$$

$$V_2 = g_{21}V_1 + g_{22}i_2$$

$$|g_{12f}| \gg |g_{12a}|;$$

$$|g_{21a}| \gg |g_{21f}|$$

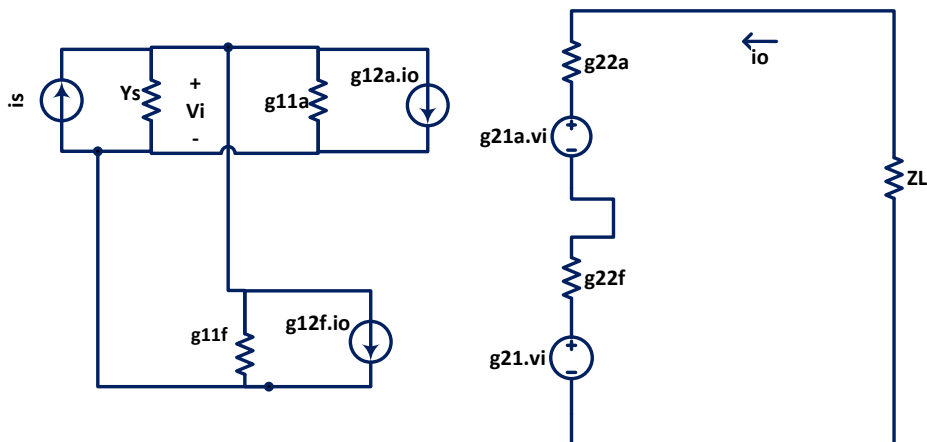

3) Shunt - Series Feedback

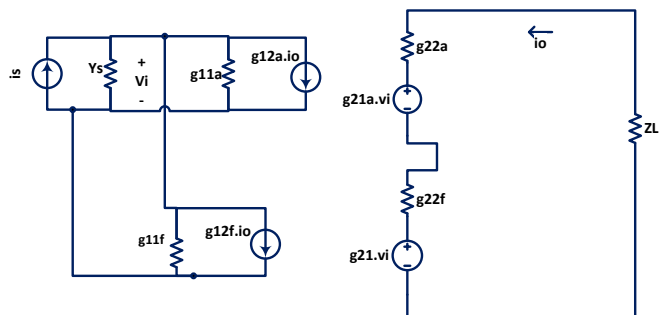

The new basic amplifier

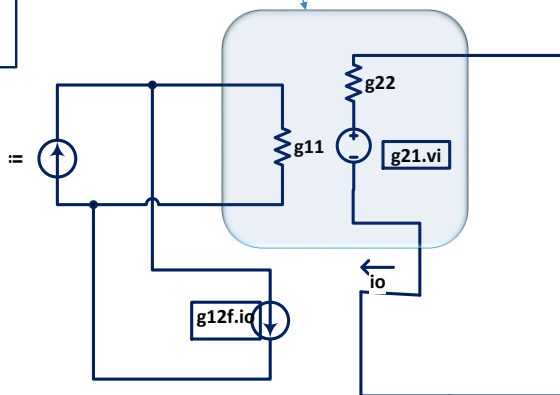

Negative Feedback

3) Shunt - Series Feedback

Example:

$$R1 || R2 = 24k$$

$$hfe = 50$$

$$hie1 = 1.3k;$$

$$hie2 = 1k$$

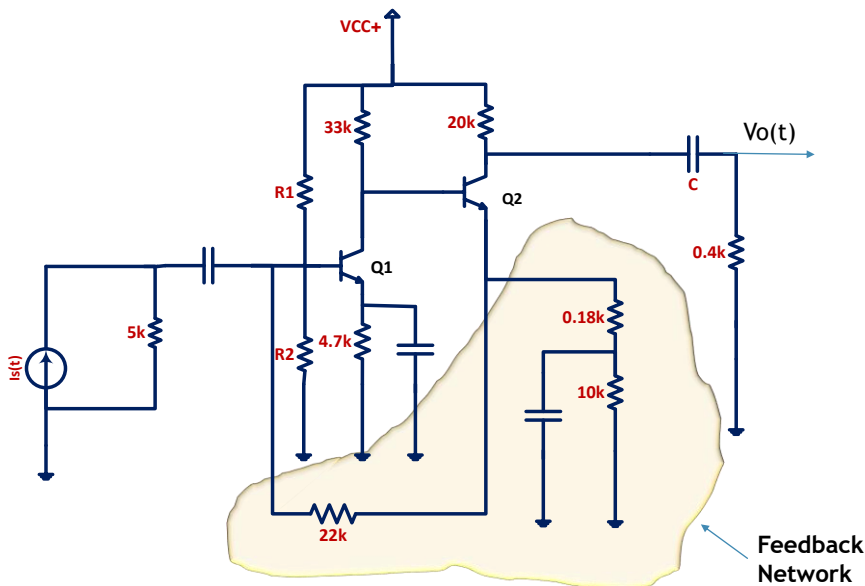

Negative Feedback

Practical configuration and the effect of loading

3) Shunt - Series Feedback

Example:

$$g_{11f} = \frac{1}{22k + 0.18k}$$

$$g_{22f} = 22k || 0.18k$$

$$g_{12f} = -\frac{0.18k}{0.18k + 22k} = B$$

The Feed-Back Network:

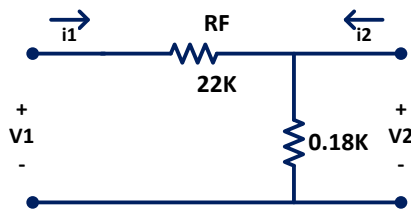

3) Shunt - Series Feedback

Example:

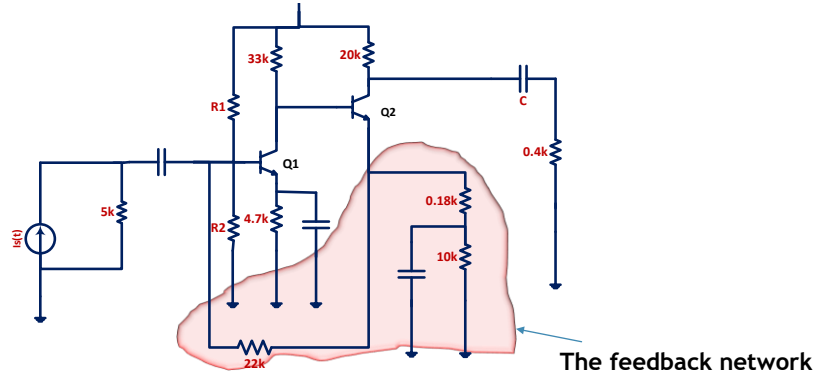

New Basic Amplifier :

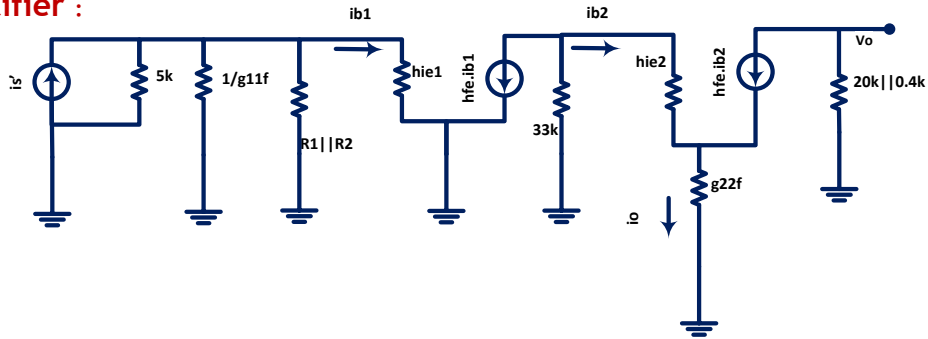

Negative Feedback

Practical configuration and the effect of loading

3) Shunt - Series Feedback

Example:

$$A = \frac{i_o}{i_{s'}}$$

$$i_o = (1 + hfe)ib_2$$

$$ib_2 = -hfe ib_1 \frac{33k}{33k + hie_2 + g_{22f}(1 + hfe)}$$

$$ib_1 = i_{s'} \frac{5k \parallel \frac{1}{g_{11f}} \parallel R_1 \parallel R_2}{5k \parallel \frac{1}{g_{11f}} \parallel R_1 \parallel R_2 + hie_1}$$

$$A = -1429$$

$$AB = 11.5$$

$$Af = \frac{i_o}{i_s} = \frac{A}{1 + AB} = -113.45$$

Negative Feedback

Practical configuration and the effect of loading

4) Series - Series Feedback

$$V_1 = Z_{11} i_1 + Z_{12} i_2$$

$$V_2 = Z_{21} i_1 + Z_{22} i_2$$

$$|Z_{12f}| \gg |Z_{12a}|$$

$$|Z_{21a}| \gg |Z_{21f}|$$

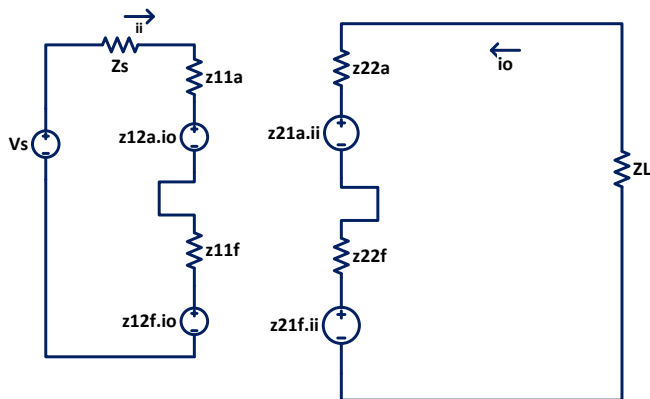

4) Series - Series Feedback

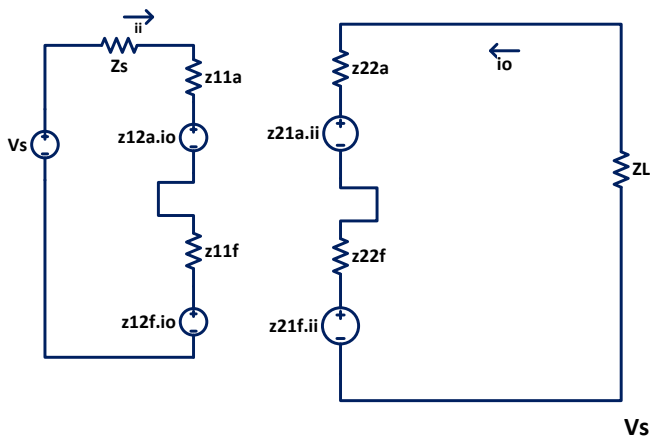

$$Z_{12f} = B$$

The new basic amplifier

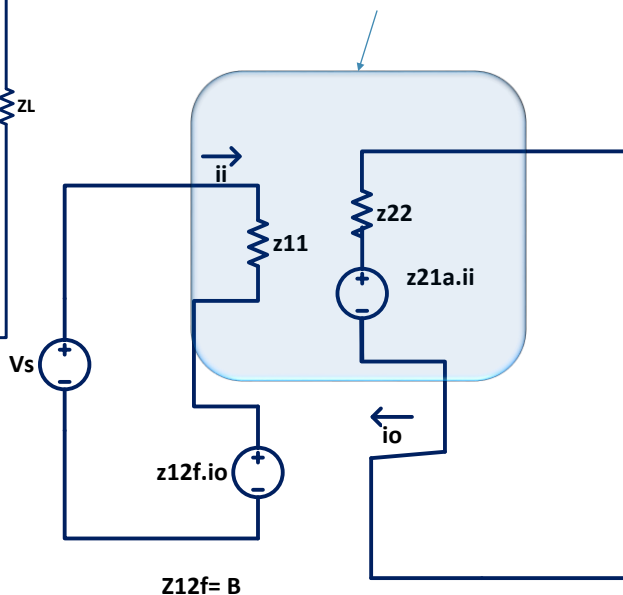

Negative Feedback

Practical configuration and the effect of loading

4) Series - Series Feedback

Example:

$$R_s = 0.6k \text{ , } R_c || R_L = 2k$$

$$R_e = 0.2k \text{ , } R_1 || R_2 = 50k$$

$$h_{ie} = 1k \text{ , } h_{fe} = 100$$

Ac small signal equivalent circuit

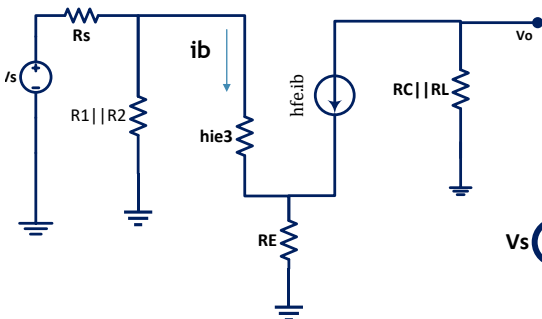
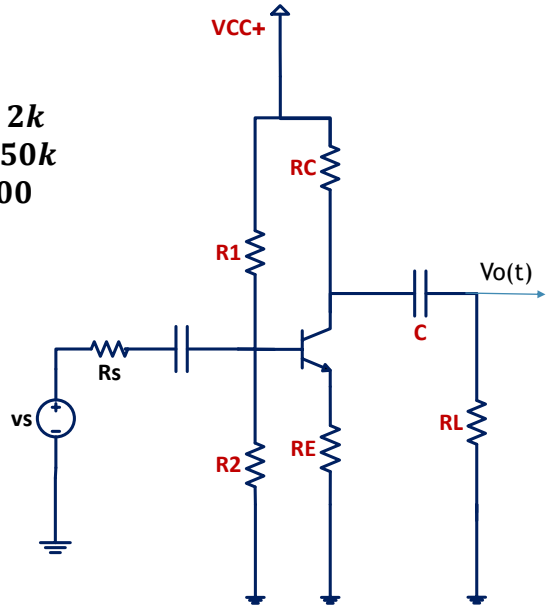
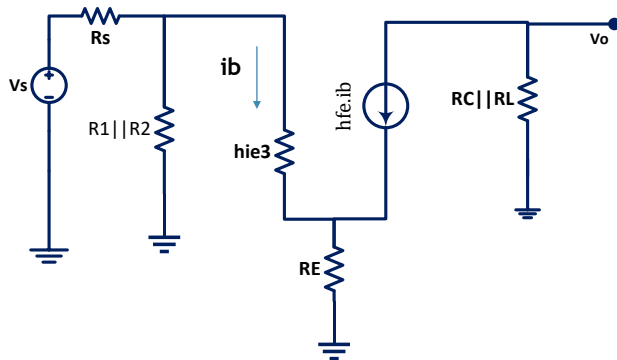

Negative Feedback

The Feed-Back Network:

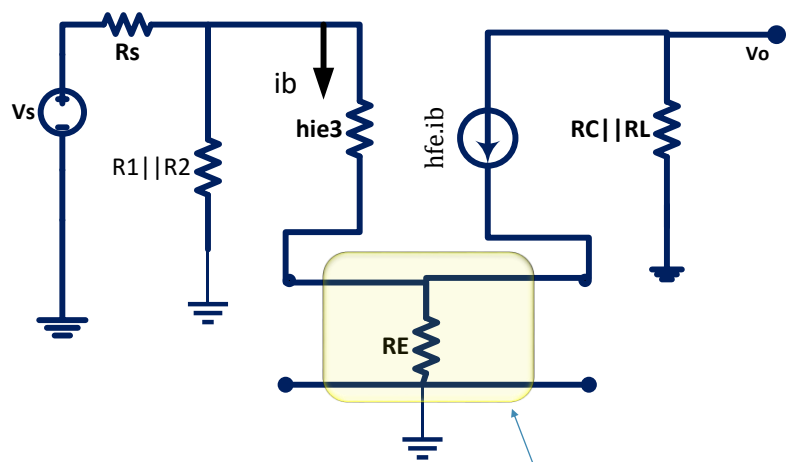
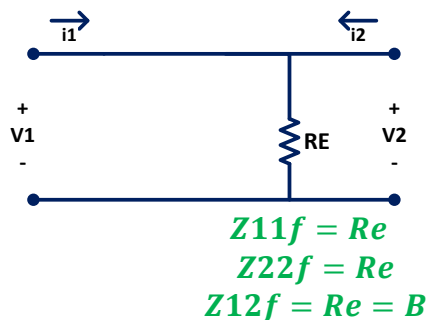

Feedback network

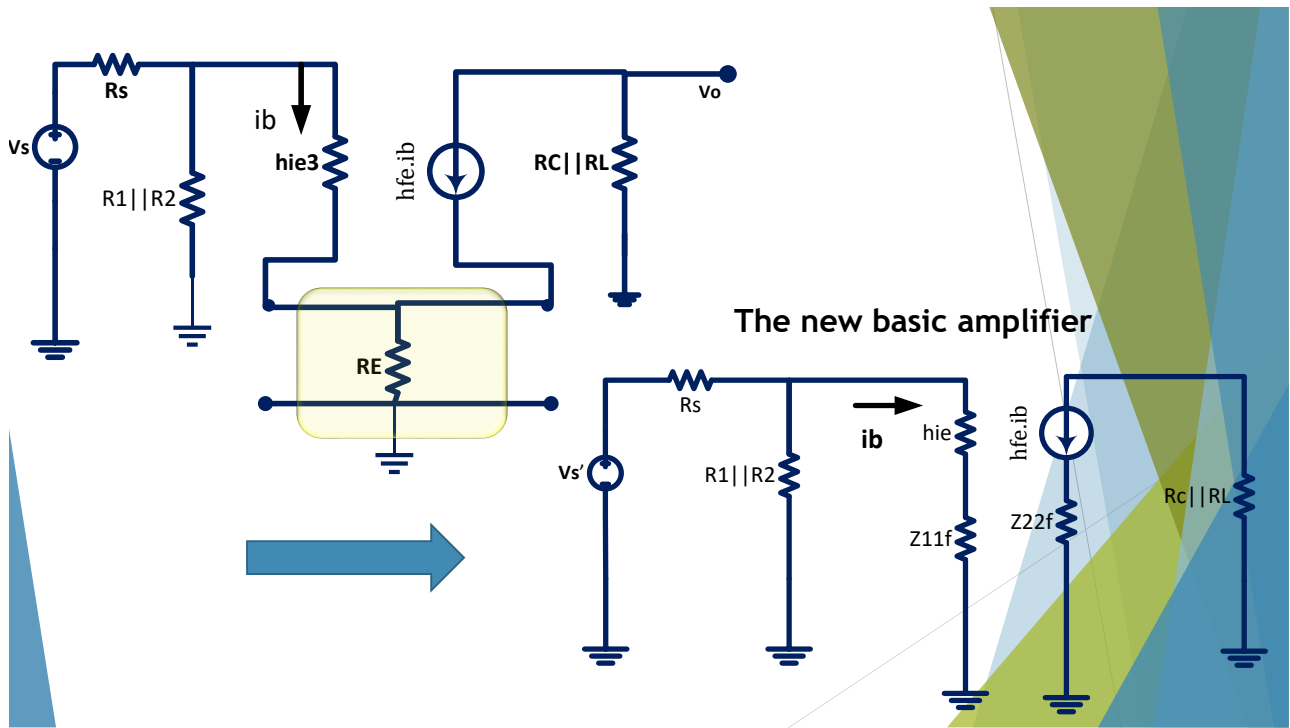

4) Series - Series Feedback

$$A = \frac{i_o}{V_{s'}}$$

$$i_o = (hfe)ib$$

$$ib = ii \frac{R1||R2}{R1||R2 + hie + Z11f}$$

$$ii = \frac{V_s}{RS + R1||R2|| (hie + Z11f)}$$

New Basic Amplifier :

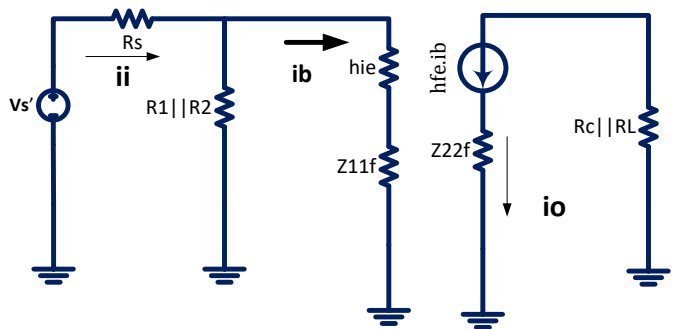

$$A = 56.4$$

$$AB = 11.29$$

$$Af = \frac{i_o}{V_s} = \frac{A}{1 + AB} = 4.59$$

$$Av = \frac{V_o}{V_s} = \frac{i_o}{V_s} \cdot \frac{V_o}{i_o} = -Af \cdot (RL||Rc)$$

$$Av = -9.18$$