

Techniques of Circuit Analysis

Assessment Problems

AP 4.1 [a] Redraw the circuit, labeling the reference node and the two node voltages:

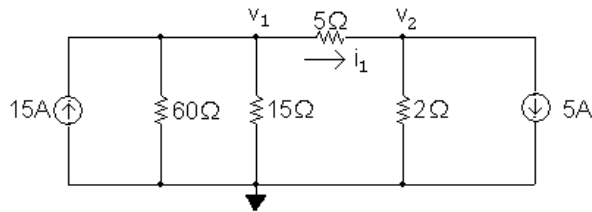

The two node voltage equations are

$$-15 + \frac{v_1}{60} + \frac{v_1}{15} + \frac{v_1 - v_2}{5} = 0$$

$$5 + \frac{v_2}{2} + \frac{v_2 - v_1}{5} = 0$$

Place these equations in standard form:

$$v_1 \left(\frac{1}{60} + \frac{1}{15} + \frac{1}{5} \right) + v_2 \left(-\frac{1}{5} \right) = 15$$

$$v_1 \left(-\frac{1}{5} \right) + v_2 \left(\frac{1}{2} + \frac{1}{5} \right) = -5$$

Solving, $v_1 = 60$ V and $v_2 = 10$ V;

Therefore, $i_1 = (v_1 - v_2)/5 = 10$ A

[b] $p_{15A} = -(15 \text{ A})v_1 = -(15 \text{ A})(60 \text{ V}) = -900 \text{ W} = 900 \text{ W}(\text{delivered})$

[c] $p_{5A} = (5 \text{ A})v_2 = (5 \text{ A})(10 \text{ V}) = 50 \text{ W} = -50 \text{ W}(\text{delivered})$

AP 4.2 Redraw the circuit, choosing the node voltages and reference node as shown:

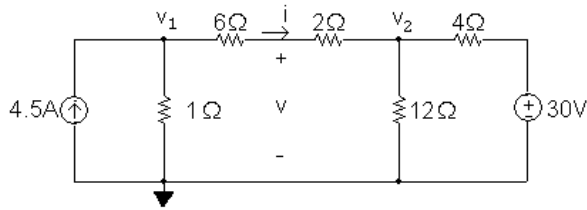

The two node voltage equations are:

$$-4.5 + \frac{v_1}{1} + \frac{v_1 - v_2}{6 + 2} = 0$$

$$\frac{v_2}{12} + \frac{v_2 - v_1}{6 + 2} + \frac{v_2 - 30}{4} = 0$$

Place these equations in standard form:

$$v_1 \left(1 + \frac{1}{8}\right) + v_2 \left(-\frac{1}{8}\right) = 4.5$$

$$v_1 \left(-\frac{1}{8}\right) + v_2 \left(\frac{1}{12} + \frac{1}{8} + \frac{1}{4}\right) = 7.5$$

Solving, $v_1 = 6 \text{ V}$ $v_2 = 18 \text{ V}$

To find the voltage v , first find the current i through the series-connected 6Ω and 2Ω resistors:

$$i = \frac{v_1 - v_2}{6 + 2} = \frac{6 - 18}{8} = -1.5 \text{ A}$$

Using a KVL equation, calculate v :

$$v = 2i + v_2 = 2(-1.5) + 18 = 15 \text{ V}$$

AP 4.3 [a] Redraw the circuit, choosing the node voltages and reference node as shown:

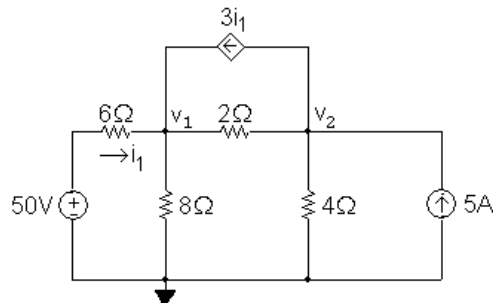

The node voltage equations are:

$$\frac{v_1 - 50}{6} + \frac{v_1}{8} + \frac{v_1 - v_2}{2} - 3i_1 = 0$$

$$-5 + \frac{v_2}{4} + \frac{v_2 - v_1}{2} + 3i_1 = 0$$

The dependent source requires the following constraint equation:

$$i_1 = \frac{50 - v_1}{6}$$

Place these equations in standard form:

$$v_1 \left(\frac{1}{6} + \frac{1}{8} + \frac{1}{2} \right) + v_2 \left(-\frac{1}{2} \right) + i_1(-3) = \frac{50}{6}$$

$$v_1 \left(-\frac{1}{2} \right) + v_2 \left(\frac{1}{4} + \frac{1}{2} \right) + i_1(3) = 5$$

$$v_1 \left(\frac{1}{6} \right) + v_2(0) + i_1(1) = \frac{50}{6}$$

Solving, $v_1 = 32 \text{ V}$; $v_2 = 16 \text{ V}$; $i_1 = 3 \text{ A}$

Using these values to calculate the power associated with each source:

$$p_{50\text{V}} = -50i_1 = -150 \text{ W}$$

$$p_{5\text{A}} = -5(v_2) = -80 \text{ W}$$

$$p_{3i_1} = 3i_1(v_2 - v_1) = -144 \text{ W}$$

[b] All three sources are delivering power to the circuit because the power computed in (a) for each of the sources is negative.

AP 4.4 Redraw the circuit and label the reference node and the node at which the node voltage equation will be written:

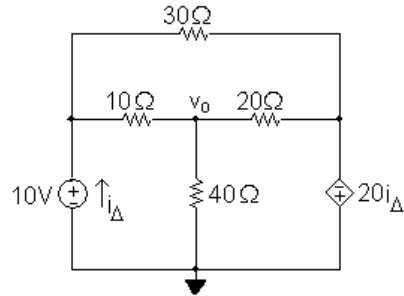

The node voltage equation is

$$\frac{v_o}{40} + \frac{v_o - 10}{10} + \frac{v_o + 20i_\Delta}{20} = 0$$

The constraint equation required by the dependent source is

$$i_\Delta = i_{10\Omega} + i_{30\Omega} = \frac{10 - v_o}{10} + \frac{10 + 20i_\Delta}{30}$$

Place these equations in standard form:

$$v_o \left(\frac{1}{40} + \frac{1}{10} + \frac{1}{20} \right) + i_\Delta(1) = 1$$

$$v_o \left(\frac{1}{10} \right) + i_\Delta \left(1 - \frac{20}{30} \right) = 1 + \frac{10}{30}$$

Solving, $i_\Delta = -3.2 \text{ A}$ and $v_o = 24 \text{ V}$

AP 4.5 Redraw the circuit identifying the three node voltages and the reference node:

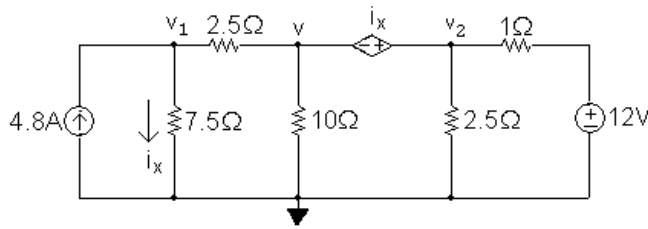

Note that the dependent voltage source and the node voltages v and v_2 form a supernode. The v_1 node voltage equation is

$$\frac{v_1}{7.5} + \frac{v_1 - v}{2.5} - 4.8 = 0$$

The supernode equation is

$$\frac{v - v_1}{2.5} + \frac{v}{10} + \frac{v_2}{2.5} + \frac{v_2 - 12}{1} = 0$$

The constraint equation due to the dependent source is

$$i_x = \frac{v_1}{7.5}$$

The constraint equation due to the supernode is

$$v + i_x = v_2$$

Place this set of equations in standard form:

$$v_1 \left(\frac{1}{7.5} + \frac{1}{2.5} \right) + v \left(-\frac{1}{2.5} \right) + v_2(0) + i_x(0) = 4.8$$

$$v_1 \left(-\frac{1}{2.5} \right) + v \left(\frac{1}{2.5} + \frac{1}{10} \right) + v_2 \left(\frac{1}{2.5} + 1 \right) + i_x(0) = 12$$

$$v_1 \left(-\frac{1}{7.5} \right) + v(0) + v_2(0) + i_x(1) = 0$$

$$v_1(0) + v(1) + v_2(-1) + i_x(1) = 0$$

Solving this set of equations gives $v_1 = 15$ V, $v_2 = 10$ V, $i_x = 2$ A, and $v = 8$ V.

AP 4.6 Redraw the circuit identifying the reference node and the two unknown node voltages. Note that the right-most node voltage is the sum of the 60 V source and the dependent source voltage.

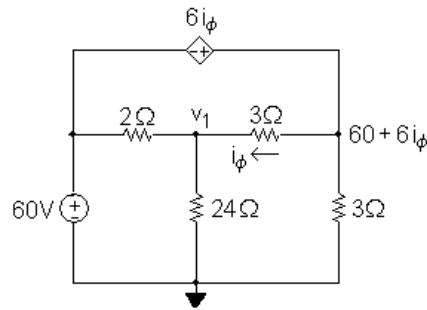

The node voltage equation at v_1 is

$$\frac{v_1 - 60}{2} + \frac{v_1}{24} + \frac{v_1 - (60 + 6i_\phi)}{3} = 0$$

The constraint equation due to the dependent source is

$$i_\phi = \frac{60 + 6i_\phi - v_1}{3}$$

Place these two equations in standard form:

$$v_1 \left(\frac{1}{2} + \frac{1}{24} + \frac{1}{3} \right) + i_\phi(-2) = 30 + 20$$

$$v_1 \left(\frac{1}{3} \right) + i_\phi(1 - 2) = 20$$

Solving, $i_\phi = -4$ A and $v_1 = 48$ V

AP 4.7 [a] Redraw the circuit identifying the three mesh currents:

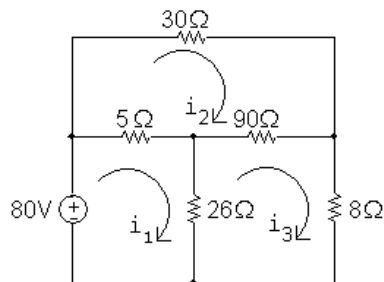

The mesh current equations are:

$$-80 + 5(i_1 - i_2) + 26(i_1 - i_3) = 0$$

$$30i_2 + 90(i_2 - i_3) + 5(i_2 - i_1) = 0$$

$$8i_3 + 26(i_3 - i_1) + 90(i_3 - i_2) = 0$$

Place these equations in standard form:

$$31i_1 - 5i_2 - 26i_3 = 80$$

$$-5i_1 + 125i_2 - 90i_3 = 0$$

$$-26i_1 - 90i_2 + 124i_3 = 0$$

Solving,

$$i_1 = 5 \text{ A}; \quad i_2 = 2 \text{ A}; \quad i_3 = 2.5 \text{ A}$$

$$p_{80\text{V}} = -(80)i_1 = -(80)(5) = -400 \text{ W}$$

Therefore the 80 V source is delivering 400 W to the circuit.

[b] $p_{8\Omega} = (8)i_3^2 = 8(2.5)^2 = 50 \text{ W}$, so the 8Ω resistor dissipates 50 W.

AP 4.8 [a] $b = 8, \quad n = 6, \quad b - n + 1 = 3$

[b] Redraw the circuit identifying the three mesh currents:

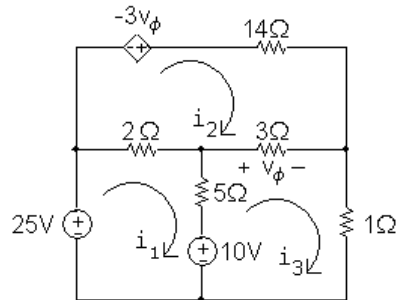

The three mesh-current equations are

$$-25 + 2(i_1 - i_2) + 5(i_1 - i_3) + 10 = 0$$

$$-(-3v_\phi) + 14i_2 + 3(i_2 - i_3) + 2(i_2 - i_1) = 0$$

$$1i_3 - 10 + 5(i_3 - i_1) + 3(i_3 - i_2) = 0$$

The dependent source constraint equation is

$$v_\phi = 3(i_3 - i_2)$$

Place these four equations in standard form:

$$7i_1 - 2i_2 - 5i_3 + 0v_\phi = 15$$

$$-2i_1 + 19i_2 - 3i_3 + 3v_\phi = 0$$

$$-5i_1 - 3i_2 + 9i_3 + 0v_\phi = 10$$

$$0i_1 + 3i_2 - 3i_3 + 1v_\phi = 0$$

Solving

$$i_1 = 4 \text{ A}; \quad i_2 = -1 \text{ A}; \quad i_3 = 3 \text{ A}; \quad v_\phi = 12 \text{ V}$$

$$p_{\text{ds}} = -(-3v_\phi)i_2 = 3(12)(-1) = -36 \text{ W}$$

Thus, the dependent source is delivering 36 W, or absorbing -36 W .

AP 4.9 Redraw the circuit identifying the three mesh currents:

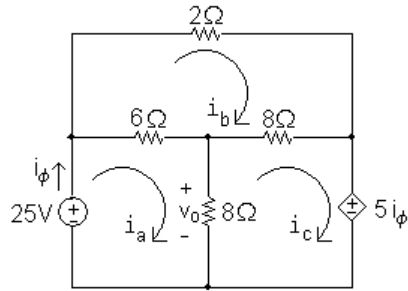

The mesh current equations are:

$$-25 + 6(i_a - i_b) + 8(i_a - i_c) = 0$$

$$2i_b + 8(i_b - i_c) + 6(i_b - i_a) = 0$$

$$5i_\phi + 8(i_c - i_a) + 8(i_c - i_b) = 0$$

The dependent source constraint equation is $i_\phi = i_a$. We can substitute this simple expression for i_ϕ into the third mesh equation and place the equations in standard form:

$$14i_a - 6i_b - 8i_c = 25$$

$$-6i_a + 16i_b - 8i_c = 0$$

$$-3i_a - 8i_b + 16i_c = 0$$

Solving,

$$i_a = 4 \text{ A}; \quad i_b = 2.5 \text{ A}; \quad i_c = 2 \text{ A}$$

Thus,

$$v_o = 8(i_a - i_c) = 8(4 - 2) = 16 \text{ V}$$

AP 4.10 Redraw the circuit identifying the mesh currents:

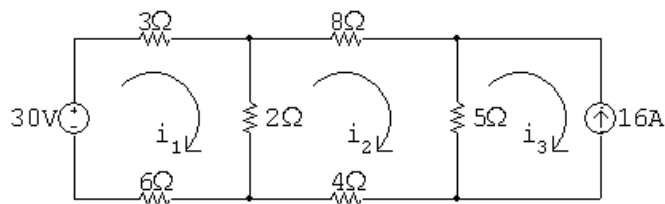

Since there is a current source on the perimeter of the i_3 mesh, we know that $i_3 = -16 \text{ A}$. The remaining two mesh equations are

$$-30 + 3i_1 + 2(i_1 - i_2) + 6i_1 = 0$$

$$8i_2 + 5(i_2 + 16) + 4i_2 + 2(i_2 - i_1) = 0$$

Place these equations in standard form:

$$11i_1 - 2i_2 = 30$$

$$-2i_1 + 19i_2 = -80$$

Solving: $i_1 = 2 \text{ A}$, $i_2 = -4 \text{ A}$, $i_3 = -16 \text{ A}$

The current in the 2Ω resistor is $i_1 - i_2 = 6 \text{ A} \therefore p_{2\Omega} = (6)^2(2) = 72 \text{ W}$

Thus, the 2Ω resistors dissipates 72 W .

AP 4.11 Redraw the circuit and identify the mesh currents:

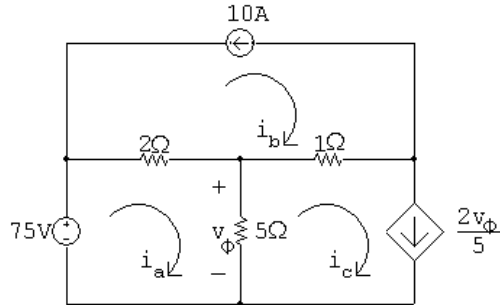

There are current sources on the perimeters of both the i_b mesh and the i_c mesh, so we know that

$$i_b = -10 \text{ A}; \quad i_c = \frac{2v_\phi}{5}$$

The remaining mesh current equation is

$$-75 + 2(i_a + 10) + 5(i_a - 0.4v_\phi) = 0$$

The dependent source requires the following constraint equation:

$$v_\phi = 5(i_a - i_c) = 5(i_a - 0.4v_\phi)$$

Place the mesh current equation and the dependent source equation in standard form:

$$7i_a - 2v_\phi = 55$$

$$5i_a - 3v_\phi = 0$$

Solving: $i_a = 15 \text{ A}$; $i_b = -10 \text{ A}$; $i_c = 10 \text{ A}$; $v_\phi = 25 \text{ V}$

Thus, $i_a = 15 \text{ A}$.

AP 4.12 Redraw the circuit and identify the mesh currents:

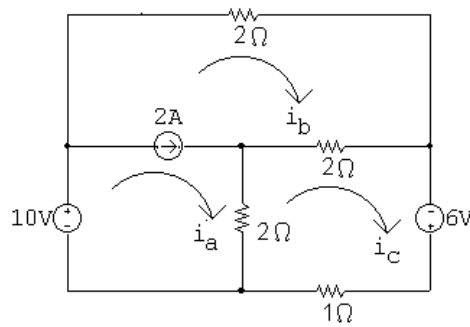

The 2 A current source is shared by the meshes i_a and i_b . Thus we combine these meshes to form a supermesh and write the following equation:

$$-10 + 2i_b + 2(i_b - i_c) + 2(i_a - i_c) = 0$$

The other mesh current equation is

$$-6 + 1i_c + 2(i_c - i_a) + 2(i_c - i_b) = 0$$

The supermesh constraint equation is

$$i_a - i_b = 2$$

Place these three equations in standard form:

$$2i_a + 4i_b - 4i_c = 10$$

$$-2i_a - 2i_b + 5i_c = 6$$

$$i_a - i_b + 0i_c = 2$$

Solving, $i_a = 7 \text{ A}$; $i_b = 5 \text{ A}$; $i_c = 6 \text{ A}$

Thus, $p_{1\Omega} = i_c^2(1) = (6)^2(1) = 36 \text{ W}$

AP 4.13 Redraw the circuit and identify the reference node and the node voltage v_1 :

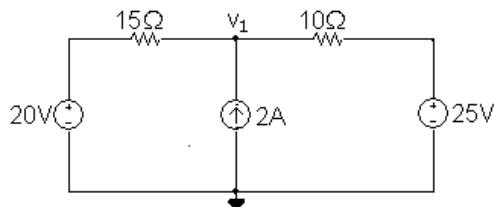

The node voltage equation is

$$\frac{v_1 - 20}{15} - 2 + \frac{v_1 - 25}{10} = 0$$

Rearranging and solving,

$$v_1 \left(\frac{1}{15} + \frac{1}{10} \right) = 2 + \frac{20}{15} + \frac{25}{10} \quad \therefore v_1 = 35 \text{ V}$$

$$p_{2A} = -35(2) = -70 \text{ W}$$

Thus the 2 A current source delivers 70 W.

AP 4.14 Redraw the circuit and identify the mesh currents:

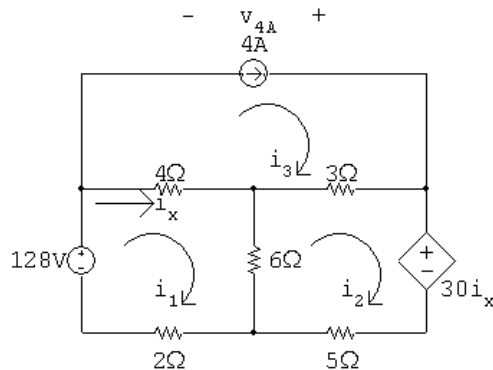

There is a current source on the perimeter of the i_3 mesh, so $i_3 = 4$ A. The other two mesh current equations are

$$-128 + 4(i_1 - 4) + 6(i_1 - i_2) + 2i_1 = 0$$

$$30i_x + 5i_2 + 6(i_2 - i_1) + 3(i_2 - 4) = 0$$

The constraint equation due to the dependent source is

$$i_x = i_1 - i_3 = i_1 - 4$$

Substitute the constraint equation into the second mesh equation and place the resulting two mesh equations in standard form:

$$12i_1 - 6i_2 = 144$$

$$24i_1 + 14i_2 = 132$$

Solving,

$$i_1 = 9 \text{ A}; \quad i_2 = -6 \text{ A}; \quad i_3 = 4 \text{ A}; \quad i_x = 9 - 4 = 5 \text{ A}$$

$$\therefore v_{4A} = 3(i_3 - i_2) - 4i_x = 10 \text{ V}$$

$$p_{4A} = -v_{4A}(4) = -(10)(4) = -40 \text{ W}$$

Thus, the 2 A current source delivers 40 W.

AP 4.15 [a] Redraw the circuit with a helpful voltage and current labeled:

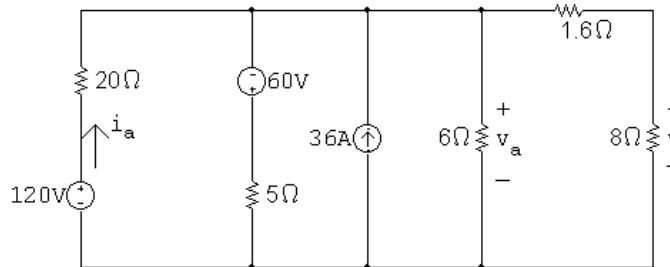

Transform the 120 V source in series with the $20\ \Omega$ resistor into a 6 A source in parallel with the $20\ \Omega$ resistor. Also transform the $-60\ \text{V}$ source in series with the $5\ \Omega$ resistor into a $-12\ \text{A}$ source in parallel with the $5\ \Omega$ resistor. The result is the following circuit:

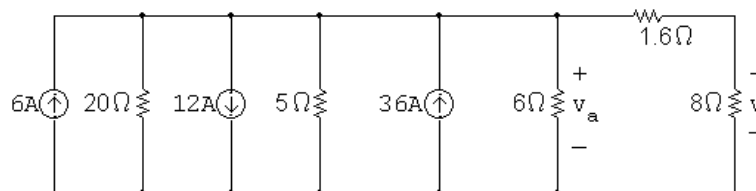

Combine the three current sources into a single current source, using KCL, and combine the $20\ \Omega$, $5\ \Omega$, and $6\ \Omega$ resistors in parallel. The resulting circuit is shown on the left. To simplify the circuit further, transform the resulting $30\ \text{A}$ source in parallel with the $2.4\ \Omega$ resistor into a $72\ \text{V}$ source in series with the $2.4\ \Omega$ resistor. Combine the $2.4\ \Omega$ resistor in series with the $1.6\ \Omega$ resistor to get a very simple circuit that still maintains the voltage v . The resulting circuit is on the right.

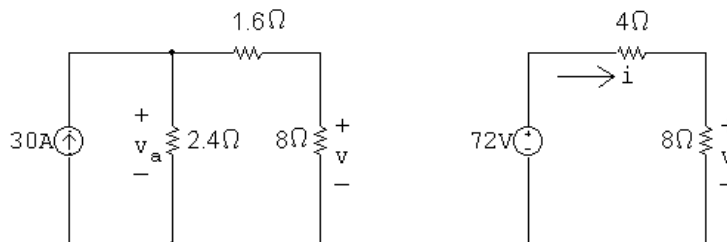

Use voltage division in the circuit on the right to calculate v as follows:

$$v = \frac{8}{12}(72) = 48\ \text{V}$$

[b] Calculate i in the circuit on the right using Ohm's law:

$$i = \frac{v}{8} = \frac{48}{8} = 6\ \text{A}$$

Now use i to calculate v_a in the circuit on the left:

$$v_a = 6(1.6 + 8) = 57.6\ \text{V}$$

Returning back to the original circuit, note that the voltage v_a is also the voltage drop across the series combination of the 120 V source and $20\ \Omega$

resistor. Use this fact to calculate the current in the 120 V source, i_a :

$$i_a = \frac{120 - v_a}{20} = \frac{120 - 57.6}{20} = 3.12 \text{ A}$$

$$p_{120\text{V}} = -(120)i_a = -(120)(3.12) = -374.40 \text{ W}$$

Thus, the 120 V source delivers 374.4 W.

AP 4.16 To find R_{Th} , replace the 72 V source with a short circuit:

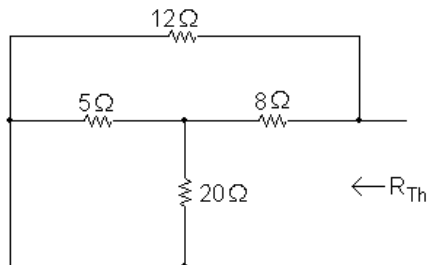

Note that the 5Ω and 20Ω resistors are in parallel, with an equivalent resistance of $5 \parallel 20 = 4 \Omega$. The equivalent 4Ω resistance is in series with the 8Ω resistor for an equivalent resistance of $4 + 8 = 12 \Omega$. Finally, the 12Ω equivalent resistance is in parallel with the 12Ω resistor, so $R_{\text{Th}} = 12 \parallel 12 = 6 \Omega$.

Use node voltage analysis to find v_{Th} . Begin by redrawing the circuit and labeling the node voltages:

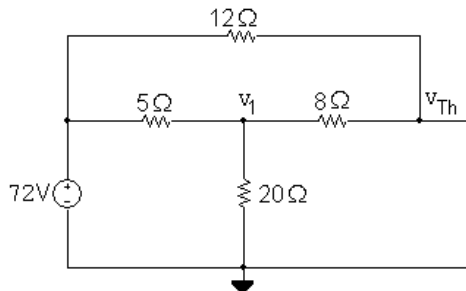

The node voltage equations are

$$\frac{v_1 - 72}{5} + \frac{v_1}{20} + \frac{v_1 - v_{\text{Th}}}{8} = 0$$

$$\frac{v_{\text{Th}} - v_1}{8} + \frac{v_{\text{Th}} - 72}{12} = 0$$

Place these equations in standard form:

$$v_1 \left(\frac{1}{5} + \frac{1}{20} + \frac{1}{8} \right) + v_{\text{Th}} \left(-\frac{1}{8} \right) = \frac{72}{5}$$

$$v_1 \left(-\frac{1}{8} \right) + v_{\text{Th}} \left(\frac{1}{8} + \frac{1}{12} \right) = 6$$

Solving, $v_1 = 60 \text{ V}$ and $v_{\text{Th}} = 64.8 \text{ V}$. Therefore, the Thévenin equivalent circuit is a 64.8 V source in series with a 6Ω resistor.

AP 4.17 We begin by performing a source transformation, turning the parallel combination of the 15 A source and $8\ \Omega$ resistor into a series combination of a 120 V source and an $8\ \Omega$ resistor, as shown in the figure on the left. Next, combine the $2\ \Omega$, $8\ \Omega$ and $10\ \Omega$ resistors in series to give an equivalent $20\ \Omega$ resistance. Then transform the series combination of the 120 V source and the $20\ \Omega$ equivalent resistance into a parallel combination of a 6 A source and a $20\ \Omega$ resistor, as shown in the figure on the right.

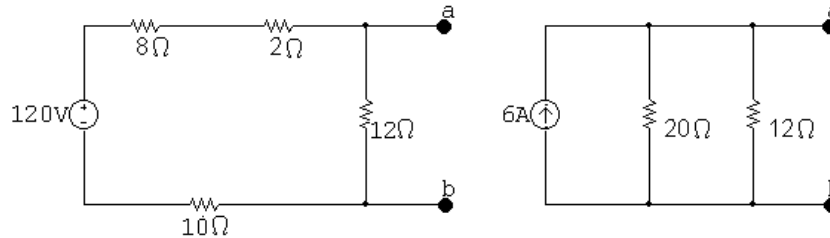

Finally, combine the $20\ \Omega$ and $12\ \Omega$ parallel resistors to give $R_N = 20\ \Omega \parallel 12\ \Omega = 7.5\ \Omega$. Thus, the Norton equivalent circuit is the parallel combination of a 6 A source and a $7.5\ \Omega$ resistor.

AP 4.18 Find the Thévenin equivalent with respect to A, B using source transformations. To begin, convert the series combination of the $-36\ \text{V}$ source and $12\ \text{k}\Omega$ resistor into a parallel combination of a $-3\ \text{mA}$ source and $12\ \text{k}\Omega$ resistor. The resulting circuit is shown below:

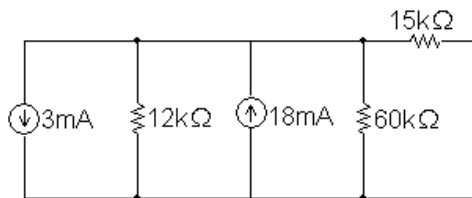

Now combine the two parallel current sources and the two parallel resistors to give a $-3 + 18 = 15\ \text{mA}$ source in parallel with a $12\ \text{k}\Omega \parallel 60\ \text{k}\Omega = 10\ \text{k}\Omega$ resistor. Then transform the 15 mA source in parallel with the $10\ \text{k}\Omega$ resistor into a 150 V source in series with a $10\ \text{k}\Omega$ resistor, and combine this $10\ \text{k}\Omega$ resistor in series with the $15\ \text{k}\Omega$ resistor. The Thévenin equivalent is thus a 150 V source in series with a $25\ \text{k}\Omega$ resistor, as seen to the left of the terminals A, B in the circuit below.

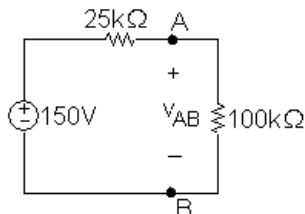

Now attach the voltmeter, modeled as a $100\ \text{k}\Omega$ resistor, to the Thévenin equivalent and use voltage division to calculate the meter reading v_{AB} :

$$v_{AB} = \frac{100,000}{125,000}(150) = 120\ \text{V}$$

AP 4.19 Begin by calculating the open circuit voltage, which is also v_{Th} , from the circuit below:

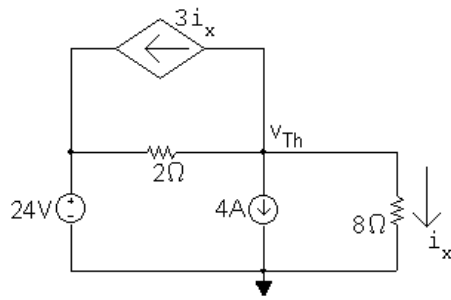

Summing the currents away from the node labeled v_{Th} We have

$$\frac{v_{Th}}{8} + 4 + 3i_x + \frac{v_{Th} - 24}{2} = 0$$

Also, using Ohm's law for the 8Ω resistor,

$$i_x = \frac{v_{Th}}{8}$$

Substituting the second equation into the first and solving for v_{Th} yields $v_{Th} = 8\text{ V}$.

Now calculate R_{Th} . To do this, we use the test source method. Replace the voltage source with a short circuit, the current source with an open circuit, and apply the test voltage v_T , as shown in the circuit below:

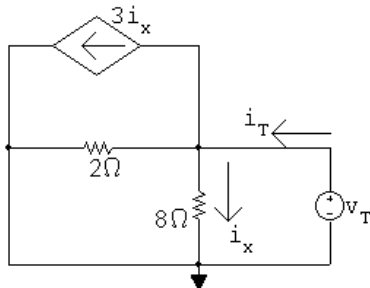

Write a KCL equation at the middle node:

$$i_T = i_x + 3i_x + v_T/2 = 4i_x + v_T/2$$

Use Ohm's law to determine i_x as a function of v_T :

$$i_x = v_T/8$$

Substitute the second equation into the first equation:

$$i_T = 4(v_T/8) + v_T/2 = v_T$$

Thus,

$$R_{Th} = v_T / i_T = 1 \Omega$$

The Thévenin equivalent is an 8 V source in series with a 1 Ω resistor.

AP 4.20 Begin by calculating the open circuit voltage, which is also v_{Th} , using the node voltage method in the circuit below:

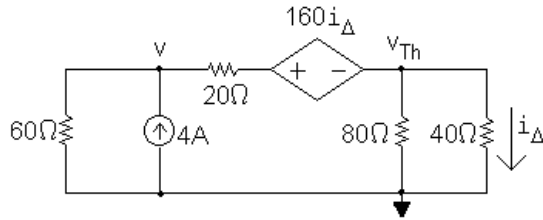

The node voltage equations are

$$\frac{v}{60} + \frac{v - (v_{Th} + 160i_{\Delta})}{20} - 4 = 0,$$

$$\frac{v_{Th}}{40} + \frac{v_{Th}}{80} + \frac{v_{Th} + 160i_{\Delta} - v}{20} = 0$$

The dependent source constraint equation is

$$i_{\Delta} = \frac{v_{Th}}{40}$$

Substitute the constraint equation into the node voltage equations and put the two equations in standard form:

$$v \left(\frac{1}{60} + \frac{1}{20} \right) + v_{Th} \left(-\frac{5}{20} \right) = 4$$

$$v \left(-\frac{1}{20} \right) + v_{Th} \left(\frac{1}{40} + \frac{1}{80} + \frac{5}{20} \right) = 0$$

Solving, $v = 172.5$ V and $v_{Th} = 30$ V.

Now use the test source method to calculate the test current and thus R_{Th} . Replace the current source with a short circuit and apply the test source to get the following circuit:

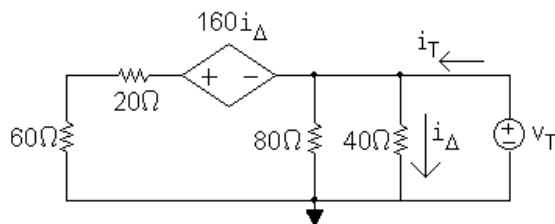

Write a KCL equation at the rightmost node:

$$i_T = \frac{v_T}{80} + \frac{v_T}{40} + \frac{v_T + 160i_{\Delta}}{80}$$

The dependent source constraint equation is

$$i_{\Delta} = \frac{v_T}{40}$$

Substitute the constraint equation into the KCL equation and simplify the right-hand side:

$$i_T = \frac{v_T}{10}$$

Therefore,

$$R_{Th} = \frac{v_T}{i_T} = 10 \Omega$$

Thus, the Thévenin equivalent is a 30 V source in series with a 10 Ω resistor.

AP 4.21 First find the Thévenin equivalent circuit. To find v_{Th} , create an open circuit between nodes a and b and use the node voltage method with the circuit below:

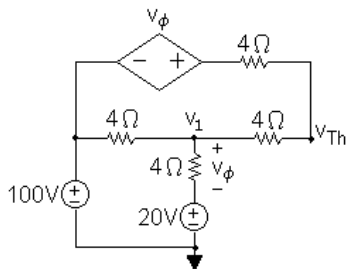

The node voltage equations are:

$$\frac{v_{Th} - (100 + v_{\phi})}{4} + \frac{v_{Th} - v_1}{4} = 0$$

$$\frac{v_1 - 100}{4} + \frac{v_1 - 20}{4} + \frac{v_1 - v_{Th}}{4} = 0$$

The dependent source constraint equation is

$$v_{\phi} = v_1 - 20$$

Place these three equations in standard form:

$$v_{Th} \left(\frac{1}{4} + \frac{1}{4} \right) + v_1 \left(-\frac{1}{4} \right) + v_{\phi} \left(-\frac{1}{4} \right) = 25$$

$$v_{Th} \left(-\frac{1}{4} \right) + v_1 \left(\frac{1}{4} + \frac{1}{4} + \frac{1}{4} \right) + v_{\phi} (0) = 30$$

$$v_{Th} (0) + v_1 (1) + v_{\phi} (-1) = 20$$

Solving, $v_{Th} = 120$ V, $v_1 = 80$ V, and $v_{\phi} = 60$ V.

Now create a short circuit between nodes a and b and use the mesh current method with the circuit below:

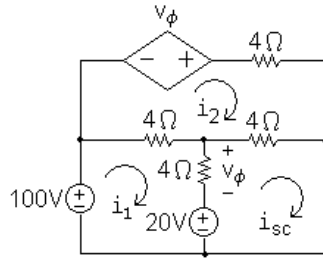

The mesh current equations are

$$-100 + 4(i_1 - i_2) + v_\phi + 20 = 0$$

$$-v_\phi + 4i_2 + 4(i_2 - i_{sc}) + 4(i_2 - i_1) = 0$$

$$-20 - v_\phi + 4(i_{sc} - i_2) = 0$$

The dependent source constraint equation is

$$v_\phi = 4(i_1 - i_{sc})$$

Place these four equations in standard form:

$$4i_1 - 4i_2 + 0i_{sc} + v_\phi = 80$$

$$-4i_1 + 12i_2 - 4i_{sc} - v_\phi = 0$$

$$0i_1 - 4i_2 + 4i_{sc} - v_\phi = 20$$

$$4i_1 + 0i_2 - 4i_{sc} - v_\phi = 0$$

Solving, $i_1 = 45$ A, $i_2 = 30$ A, $i_{sc} = 40$ A, and $v_\phi = 20$ V. Thus,

$$R_{Th} = \frac{v_{Th}}{i_{sc}} = \frac{120}{40} = 3\Omega$$

[a] For maximum power transfer, $R = R_{Th} = 3\Omega$

[b] The Thévenin voltage, $v_{Th} = 120$ V, splits equally between the Thévenin resistance and the load resistance, so

$$v_{load} = \frac{120}{2} = 60\text{ V}$$

Therefore,

$$p_{max} = \frac{v_{load}^2}{R_{load}} = \frac{60^2}{3} = 1200\text{ W}$$

AP 4.22 Substituting the value $R = 3\Omega$ into the circuit and identifying three mesh currents we have the circuit below:

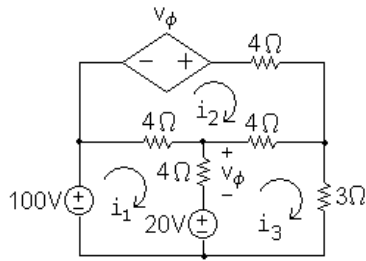

The mesh current equations are:

$$-100 + 4(i_1 - i_2) + v_\phi + 20 = 0$$

$$-v_\phi + 4i_2 + 4(i_2 - i_3) + 4(i_2 - i_1) = 0$$

$$-20 - v_\phi + 4(i_3 - i_2) + 3i_3 = 0$$

The dependent source constraint equation is

$$v_\phi = 4(i_1 - i_3)$$

Place these four equations in standard form:

$$4i_1 - 4i_2 + 0i_3 + v_\phi = 80$$

$$-4i_1 + 12i_2 - 4i_3 - v_\phi = 0$$

$$0i_1 - 4i_2 + 7i_3 - v_\phi = 20$$

$$4i_1 + 0i_2 - 4i_3 - v_\phi = 0$$

Solving, $i_1 = 30$ A, $i_2 = 20$ A, $i_3 = 20$ A, and $v_\phi = 40$ V.

- [a] $p_{100V} = -(100)i_1 = -(100)(30) = -3000$ W. Thus, the 100 V source is delivering 3000 W.
- [b] $p_{\text{depsource}} = -v_\phi i_2 = -(40)(20) = -800$ W. Thus, the dependent source is delivering 800 W.
- [c] From Assessment Problem 4.21(b), the power delivered to the load resistor is 1200 W, so the load power is $(1200/3800)100 = 31.58\%$ of the combined power generated by the 100 V source and the dependent source.

Problems

P 4.1

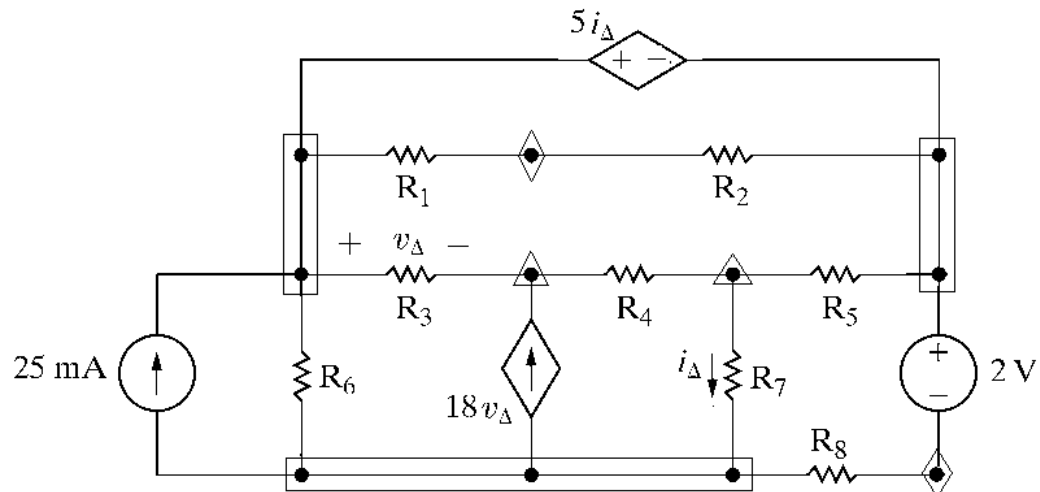

- [a] 12 branches, 8 branches with resistors, 2 branches with independent sources, 2 branches with dependent sources.
- [b] The current is unknown in every branch except the one containing the 25 mA current source, so the current is unknown in 11 branches.
- [c] 10 essential branches – $R_1 - R_2$ forms an essential branch as does $R_8 - 2$ V. The remaining eight branches are essential branches that contain a single element.
- [d] The current is known only in the essential branch containing the current source, and is unknown in the remaining 9 essential branches
- [e] From the figure there are 7 nodes – three identified by rectangular boxes, two identified by triangles, and two identified by diamonds.
- [f] There are 5 essential nodes, three identified with rectangular boxes and two identified with triangles.
- [g] A mesh is like a window pane, and as can be seen from the figure there are 6 window panes or meshes.
- P 4.2 [a] From Problem 4.1(d) there are 9 essential branches where the current is unknown, so we need 9 simultaneous equations to describe the circuit.
- [b] From Problem 4.1(f), there are 5 essential nodes, so we can apply KCL at $(5 - 1) = 4$ of these essential nodes. There would also be a dependent source constraint equation.
- [c] The remaining 4 equations needed to describe the circuit will be derived from KVL equations.

- [d] We must avoid using the bottom left-most mesh, since it contains a current source, and we have no way of determining the voltage drop across a current source. The two meshes on the bottom that share the dependent source must be handled in a special way.

P 4.3 [a] There are eight circuit components, seven resistors and the voltage source. Therefore there are **eight** unknown currents. However, the voltage source and the R_1 resistor are in series, so have the same current. The R_4 and R_6 resistors are also in series, so have the same current. The R_5 and R_7 resistors are in series, so have the same current. Therefore, we only need 5 equations to find the 5 distinct currents in this circuit.

[b]

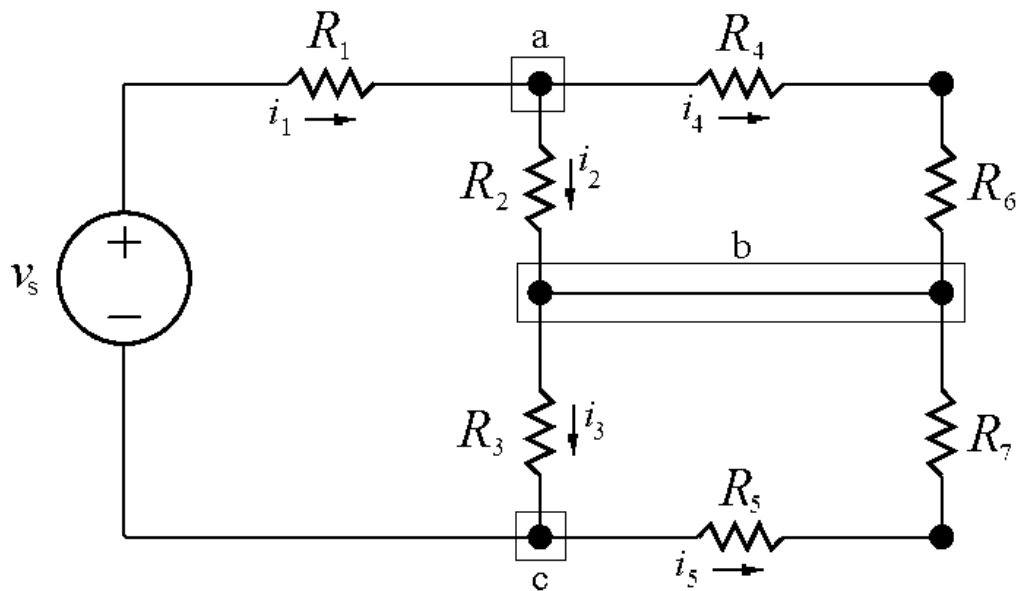

There are three essential nodes in this circuit, identified by the boxes. At two of these nodes you can write KCL equations that will be independent of one another. A KCL equation at the third node would be dependent on the first two. Therefore there are **two** independent KCL equations.

- [c] Sum the currents at any two of the three essential nodes a, b, and c. Using nodes a and c we get

$$-i_1 + i_2 + i_4 = 0$$

$$i_1 - i_3 + i_5 = 0$$

- [d] There are three meshes in this circuit: one on the left with the components v_s , R_1 , R_2 and R_3 ; one on the top right with components R_2 , R_4 , and R_6 ; and one on the bottom right with components R_3 , R_5 , and R_7 . We can write KVL equations for all three meshes, giving a total of **three** independent KVL equations.

$$[e] -v_s + R_1 i_1 + R_2 i_2 + R_3 i_3 = 0$$

$$R_4 i_4 + R_6 i_4 - R_2 i_2 = 0$$

$$R_3 i_3 + R_5 i_5 + R_7 i_5 = 0$$

P 4.4

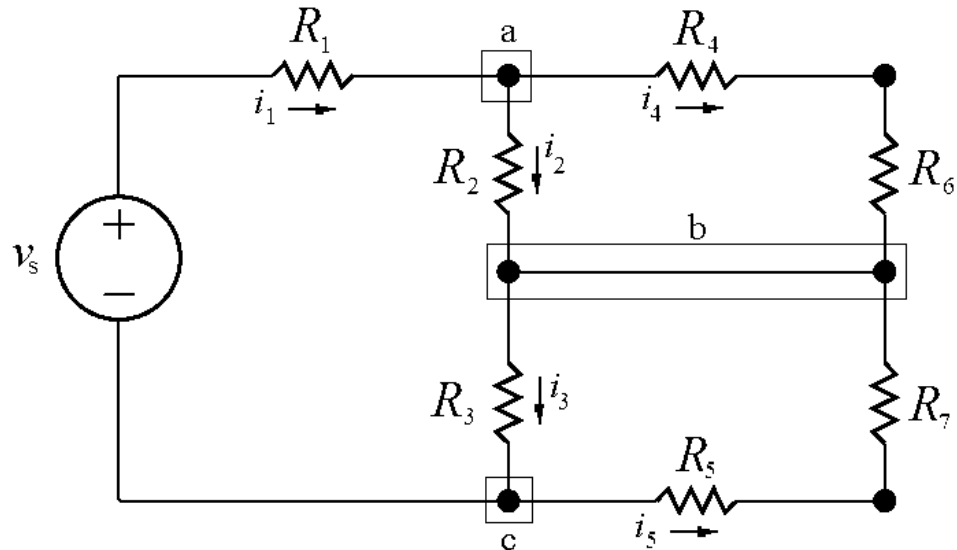

$$[a] \text{ At node a: } -i_1 + i_2 + i_4 = 0$$

$$\text{At node b: } -i_2 + i_3 - i_4 - i_5 = 0$$

$$\text{At node c: } i_1 - i_3 + i_5 = 0$$

[b] There are many possible solutions. For example, adding the equations at nodes a and c gives the equation at node b:

$$(-i_1 + i_2 + i_4) + (i_1 - i_3 + i_5) = 0 \quad \text{so} \quad i_2 - i_3 + i_4 + i_5 = 0$$

This is the equation at node b with both sides multiplied by -1 .

P 4.5

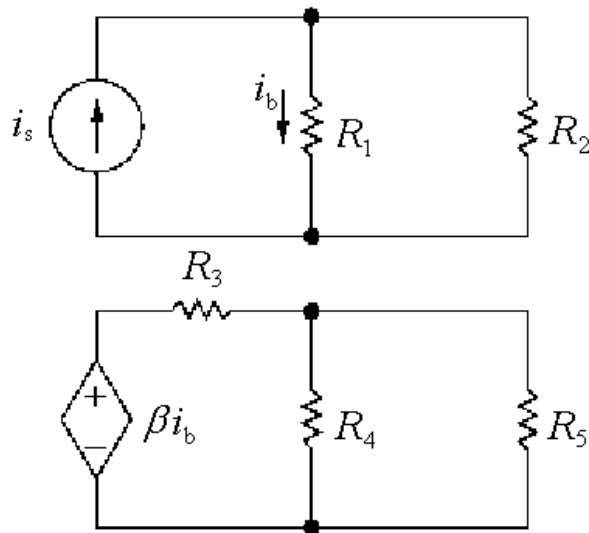

- [a] As can be seen from the figure, the circuit has 2 separate parts.
- [b] There are 5 nodes – the four black dots and the node between the voltage source and the resistor R_3 .
- [c] There are 7 branches, each containing one of the seven circuit components.
- [d] When a conductor joins the lower nodes of the two separate parts, there is now only a single part in the circuit. There would now be 4 nodes, because the two lower nodes are now joined as a single node. The number of branches remains at 7, where each branch contains one of the seven individual circuit components.

P 4.6 Use the lower terminal of the $25\ \Omega$ resistor as the reference node.

$$\frac{v_o - 24}{20 + 80} + \frac{v_o}{25} + 0.04 = 0$$

Solving, $v_o = 4\ \text{V}$

P 4.7 [a] From the solution to Problem 4.6 we know $v_o = 4\ \text{V}$, therefore

$$p_{40\text{mA}} = 0.04v_o = 0.16\ \text{W}$$

$$\therefore p_{40\text{mA}} \text{ (developed)} = -160\ \text{mW}$$

[b] The current into the negative terminal of the $24\ \text{V}$ source is

$$i_g = \frac{24 - 4}{20 + 80} = 0.2\ \text{A}$$

$$p_{24\text{V}} = -24(0.2) = -4.8\ \text{W}$$

$$\therefore p_{24\text{V}} \text{ (developed)} = 4800\ \text{mW}$$

$$\begin{aligned}
 \text{[c]} \quad p_{20\Omega} &= (0.2)^2(20) = 800 \text{ mW} \\
 p_{80\Omega} &= (0.2)^2(80) = 3200 \text{ mW} \\
 p_{25\Omega} &= (4)^2/25 = 640 \text{ mW} \\
 \sum p_{\text{dev}} &= 4800 \text{ mW} \\
 \sum p_{\text{dis}} &= 160 + 800 + 3200 + 640 = 4800 \text{ mW}
 \end{aligned}$$

$$\text{P 4.8 [a]} \quad \frac{v_o - 24}{20 + 80} + \frac{v_o}{25} + 0.04 = 0; \quad v_o = 4 \text{ V}$$

[b] Let v_x = voltage drop across 40 mA source

$$v_x = v_o - (50)(0.04) = 2 \text{ V}$$

$$p_{40\text{mA}} = (2)(0.04) = 80 \text{ mW} \quad \text{so} \quad p_{40\text{mA}} \text{ (developed)} = -80 \text{ mW}$$

[c] Let i_g = be the current into the positive terminal of the 24 V source

$$i_g = (4 - 24)/100 = -0.2 \text{ A}$$

$$p_{24\text{V}} = (-0.2)(24) = -4800 \text{ mW} \quad \text{so} \quad p_{24\text{V}} \text{ (developed)} = 4800 \text{ mW}$$

$$\begin{aligned}
 \text{[d]} \quad \sum p_{\text{dis}} &= (0.2)^2(20) + (0.2)^2(80) + (4)^2/25 + (0.04)^2(50) + 0.08 \\
 &= 4800 \text{ mW}
 \end{aligned}$$

[e] v_o is independent of any finite resistance connected in series with the 40 mA current source

P 4.9

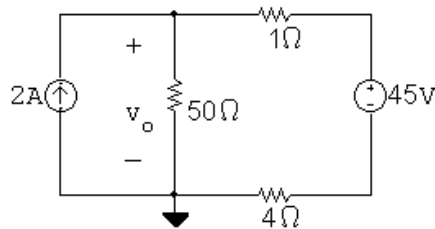

$$-2 + \frac{v_o}{50} + \frac{v_o - 45}{1 + 4} = 0$$

$$v_o = 50 \text{ V}$$

$$p_{2\text{A}} = -(50)(2) = -100 \text{ W} \quad (\text{delivering})$$

The 2 A source extracts -100 W from the circuit, because it delivers 100 W to the circuit.

$$\text{P 4.10 [a]} \quad \frac{v_o - v_1}{R} + \frac{v_o - v_2}{R} + \frac{v_o - v_3}{R} + \cdots + \frac{v_o - v_n}{R} = 0$$

$$\therefore nv_o = v_1 + v_2 + v_3 + \cdots + v_n$$

$$\therefore v_o = \frac{1}{n}[v_1 + v_2 + v_3 + \cdots + v_n] = \frac{1}{n} \sum_{k=1}^n v_k$$

$$\text{[b]} \quad v_o = \frac{1}{3}(100 + 80 - 60) = 40 \text{ V}$$

P 4.11 [a]

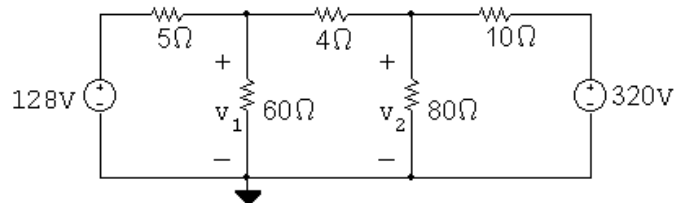

$$\frac{v_1 - 128}{5} + \frac{v_1}{60} + \frac{v_1 - v_2}{4} = 0$$

$$\frac{v_2 - v_1}{4} + \frac{v_2}{80} + \frac{v_2 - 320}{10} = 0$$

In standard form,

$$v_1 \left(\frac{1}{5} + \frac{1}{60} + \frac{1}{4} \right) + v_2 \left(-\frac{1}{4} \right) = \frac{128}{5}$$

$$v_1 \left(-\frac{1}{4} \right) + v_2 \left(\frac{1}{4} + \frac{1}{80} + \frac{1}{10} \right) = \frac{320}{10}$$

Solving, $v_1 = 162 \text{ V}$; $v_2 = 200 \text{ V}$

$$i_a = \frac{128 - 162}{5} = -6.8 \text{ A}$$

$$i_b = \frac{162}{60} = 2.7 \text{ A}$$

$$i_c = \frac{162 - 200}{4} = -9.5 \text{ A}$$

$$i_d = \frac{200}{80} = 2.5 \text{ A}$$

$$i_e = \frac{200 - 320}{10} = -12 \text{ A}$$

$$\text{[b]} \quad p_{128V} = -(128)(-6.8) = 870.4 \text{ W (abs)}$$

$$p_{320V} = (320)(-12) = -3840 \text{ W (dev)}$$

Therefore, the total power developed is 3840 W.

P 4.12

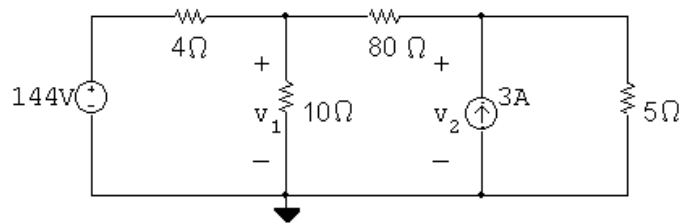

$$\frac{v_1 - 144}{4} + \frac{v_1}{10} + \frac{v_1 - v_2}{80} = 0 \quad \text{so} \quad 29v_1 - v_2 = 2880$$

$$-3 + \frac{v_2 - v_1}{80} + \frac{v_2}{5} = 0 \quad \text{so} \quad -v_1 + 17v_2 = 240$$

Solving, $v_1 = 100 \text{ V}$; $v_2 = 20 \text{ V}$

$$\text{P 4.13} \quad -6 + \frac{v_1}{40} + \frac{v_1 - v_2}{8} = 0$$

$$\frac{v_2 - v_1}{8} + \frac{v_2}{80} + \frac{v_2}{120} + 1 = 0$$

Solving, $v_1 = 120 \text{ V}$; $v_2 = 96 \text{ V}$

CHECK:

$$p_{40\Omega} = \frac{(120)^2}{40} = 360 \text{ W}$$

$$p_{8\Omega} = \frac{(120 - 96)^2}{8} = 72 \text{ W}$$

$$p_{80\Omega} = \frac{(96)^2}{80} = 115.2 \text{ W}$$

$$p_{120\Omega} = \frac{(96)^2}{120} = 76.8 \text{ W}$$

$$p_{6A} = -(6)(120) = -720 \text{ W}$$

$$p_{1A} = (1)(96) = 96 \text{ W}$$

$$\sum p_{\text{abs}} = 360 + 72 + 115.2 + 76.8 + 96 = 720 \text{ W}$$

$$\sum p_{\text{dev}} = 720 \text{ W} \quad (\text{CHECKS})$$

P 4.14 [a]

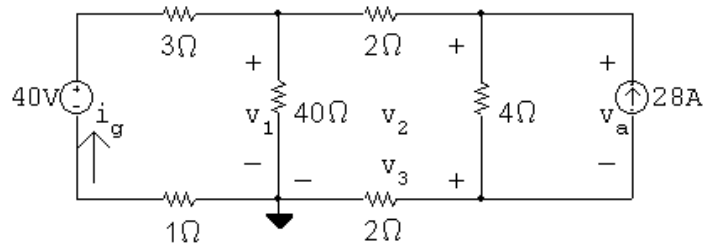

$$\frac{v_1}{40} + \frac{v_1 - 40}{4} + \frac{v_1 - v_2}{2} = 0 \quad \text{so} \quad 31v_1 - 20v_2 + 0v_3 = 400$$

$$\frac{v_2 - v_1}{2} + \frac{v_2 - v_3}{4} - 28 = 0 \quad \text{so} \quad -2v_1 + 3v_2 - v_3 = 112$$

$$\frac{v_3}{2} + \frac{v_3 - v_2}{4} + 28 = 0 \quad \text{so} \quad 0v_1 - v_2 + 3v_3 = -112$$

Solving, $v_1 = 60 \text{ V}$; $v_2 = 73 \text{ V}$; $v_3 = -13 \text{ V}$,

[b] $i_g = \frac{40 - 60}{4} = -5 \text{ A}$

$$p_g = (40)(-5) = -200 \text{ W}$$

Thus the 40 V source delivers 200 W of power.

P 4.15 [a]

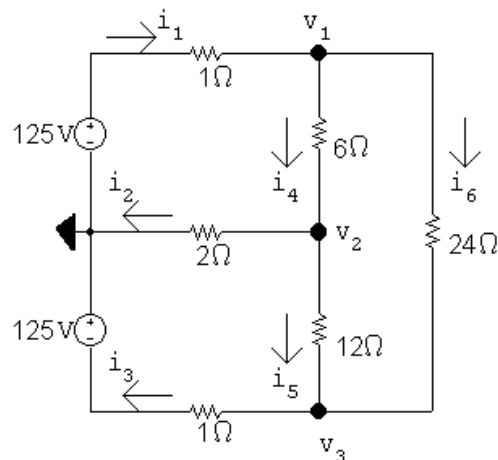

$$\frac{v_1 - 125}{1} + \frac{v_1 - v_2}{6} + \frac{v_1 - v_3}{24} = 0$$

$$\frac{v_2 - v_1}{6} + \frac{v_2}{2} + \frac{v_2 - v_3}{12} = 0$$

$$\frac{v_3 + 125}{1} + \frac{v_3 - v_2}{12} + \frac{v_3 - v_1}{24} = 0$$

In standard form:

$$\begin{aligned} v_1 \left(\frac{1}{1} + \frac{1}{6} + \frac{1}{24} \right) + v_2 \left(-\frac{1}{6} \right) + v_3 \left(-\frac{1}{24} \right) &= 125 \\ v_1 \left(-\frac{1}{6} \right) + v_2 \left(\frac{1}{6} + \frac{1}{2} + \frac{1}{12} \right) + v_3 \left(-\frac{1}{12} \right) &= 0 \\ v_1 \left(-\frac{1}{24} \right) + v_2 \left(-\frac{1}{12} \right) + v_3 \left(\frac{1}{1} + \frac{1}{12} + \frac{1}{24} \right) &= -125 \end{aligned}$$

Solving, $v_1 = 101.24 \text{ V}$; $v_2 = 10.66 \text{ V}$; $v_3 = -106.57 \text{ V}$

$$\begin{aligned} \text{Thus, } i_1 &= \frac{125 - v_1}{1} = 23.76 \text{ A} & i_4 &= \frac{v_1 - v_2}{6} = 15.10 \text{ A} \\ i_2 &= \frac{v_2}{2} = 5.33 \text{ A} & i_5 &= \frac{v_2 - v_3}{12} = 9.77 \text{ A} \\ i_3 &= \frac{v_3 + 125}{1} = 18.43 \text{ A} & i_6 &= \frac{v_1 - v_3}{24} = 8.66 \text{ A} \end{aligned}$$

$$[\text{b}] \sum P_{\text{dev}} = 125i_1 + 125i_3 = 5273.09 \text{ W}$$

$$\sum P_{\text{dis}} = i_1^2(1) + i_2^2(2) + i_3^2(1) + i_4^2(6) + i_5^2(12) + i_6^2(24) = 5273.09 \text{ W}$$

P 4.16

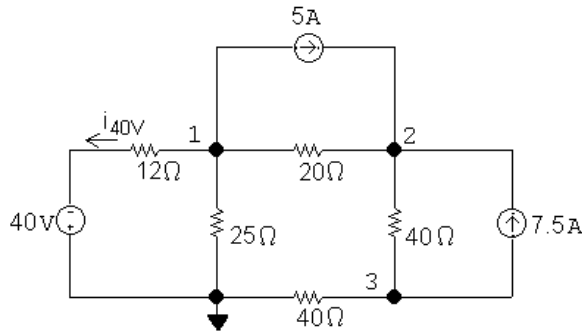

$$\frac{v_1 + 40}{12} + \frac{v_1}{25} + \frac{v_1 - v_2}{20} + 5 = 0$$

$$\left[\frac{v_2 - v_1}{20} \right] - 5 + \frac{v_2 - v_1}{40} + -7.5 = 0$$

$$\frac{v_3}{40} + \frac{v_3 - v_2}{40} + 7.5 = 0$$

$$\text{Solving, } v_1 = -10 \text{ V}; \quad v_2 = 132 \text{ V}; \quad v_3 = -84 \text{ V}; \quad i_{40\text{V}} = \frac{-10 + 40}{12} = 2.5 \text{ A}$$

$$p_{5\text{A}} = 5(v_1 - v_2) = 5(-10 - 132) = -710 \text{ W} \quad (\text{del})$$

$$p_{7.5A} = (-84 - 132)(7.5) = -1620 \text{ W} \quad (\text{del})$$

$$p_{40V} = -(40)(2.5) = -100 \text{ W} \quad (\text{del})$$

$$p_{12\Omega} = (2.5)^2(12) = 75 \text{ W}$$

$$p_{25\Omega} = \frac{v_1^2}{25} = \frac{10^2}{25} = 4 \text{ W}$$

$$p_{20\Omega} = \frac{(v_1 - v_2)^2}{20} = \frac{142^2}{20} = 1008.2 \text{ W}$$

$$p_{40\Omega(\text{lower})} = \frac{(v_3)^2}{40} = \frac{84^2}{40} = 176.4 \text{ W}$$

$$p_{40\Omega(\text{right})} = \frac{(v_2 - v_3)^2}{40} = \frac{216^2}{40} = 1166.4 \text{ W}$$

$$\sum p_{\text{diss}} = 75 + 4 + 1008.2 + 176.4 + 1166.4 = 2430 \text{ W}$$

$$\sum p_{\text{dev}} = 710 + 1620 + 100 = 2430 \text{ W} \quad (\text{CHECKS})$$

The total power dissipated in the circuit is 2430 W.

$$\text{P 4.17} \quad -3 + \frac{v_o}{200} + \frac{v_o + 5i_\Delta}{10} + \frac{v_o - 80}{20} = 0; \quad i_\Delta = \frac{v_o - 80}{20}$$

[a] Solving, $v_o = 50 \text{ V}$

$$[\text{b}] \quad i_{\text{ds}} = \frac{v_o + 5i_\Delta}{10}$$

$$i_\Delta = (50 - 80)/20 = -1.5 \text{ A}$$

$$\therefore i_{\text{ds}} = 4.25 \text{ A}; \quad 5i_\Delta = -7.5 \text{ V}; \quad p_{\text{ds}} = (-5i_\Delta)(i_{\text{ds}}) = 31.875 \text{ W}$$

[c] $p_{3A} = -3v_o = -3(50) = -150 \text{ W} \quad (\text{del})$

$$p_{80V} = 80i_\Delta = 80(-1.5) = -120 \text{ W} \quad (\text{del})$$

$$\sum p_{\text{del}} = 150 + 120 = 270 \text{ W}$$

CHECK:

$$p_{200\Omega} = 2500/200 = 12.5 \text{ W}$$

$$p_{20\Omega} = (80 - 50)^2/20 = 900/20 = 45 \text{ W}$$

$$p_{10\Omega} = (4.25)^2(10) = 180.625 \text{ W}$$

$$\sum p_{\text{diss}} = 31.875 + 180.625 + 12.5 + 45 = 270 \text{ W}$$

P 4.18

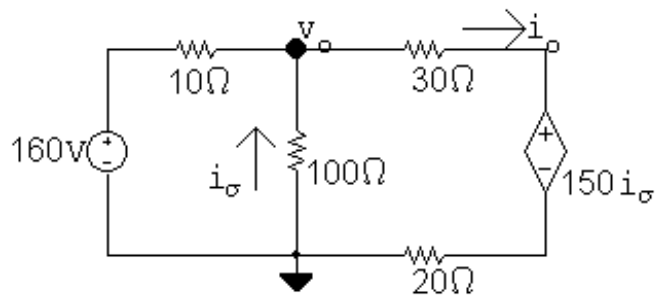

$$\frac{v_o - 160}{10} + \frac{v_o}{100} + \frac{v_o - 150i_\sigma}{50} = 0; \quad i_\sigma = -\frac{v_o}{100}$$

Solving, $v_o = 100 \text{ V}; \quad i_\sigma = -1 \text{ A}$

$$i_o = \frac{100 - (150)(-1)}{50} = 5 \text{ A}$$

$$p_{150i_\sigma} = 150i_\sigma i_o = -750 \text{ W}$$

∴ The dependent voltage source delivers 750 W to the circuit.

P 4.19

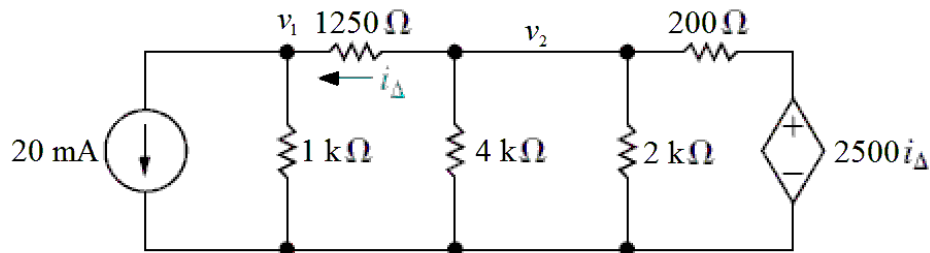

[a] $0.02 + \frac{v_1}{1000} + \frac{v_1 - v_2}{1250} = 0$

$$\frac{v_2 - v_1}{1250} + \frac{v_2}{4000} + \frac{v_2}{2000} + \frac{v_2 - 2500i_\Delta}{200} = 0$$

$$i_\Delta = \frac{v_2 - v_1}{1250}$$

Solving,

$$v_1 = 60 \text{ V}; \quad v_2 = 160 \text{ V}; \quad i_\Delta = 80 \text{ mA}$$

$$P_{20\text{mA}} = (0.02)v_1 = (0.02)(60) = 1.2 \text{ W (absorbed)}$$

$$i_{\text{ds}} = \frac{v_2 - 2500i_\Delta}{200} = \frac{160 - (2500)(0.08)}{200} = -0.2 \text{ A}$$

$$P_{\text{ds}} = (2500i_\Delta)i_{\text{ds}} = 2500(0.08)(-0.2) = -40 \text{ W (40 W developed)}$$

$$P_{\text{developed}} = 40 \text{ W}$$

$$[b] P_{1k} = \frac{v_1^2}{1000} = \frac{60^2}{1000} = 3.6 \text{ W}$$

$$P_{1250} = 1250i_{\Delta}^2 = 1250(0.08)^2 = 8 \text{ W}$$

$$P_{4k} = \frac{v_2^2}{4000} = \frac{160^2}{4000} = 6.4 \text{ W}$$

$$P_{2k} = \frac{v_2^2}{2000} = \frac{160^2}{2000} = 12.8 \text{ W}$$

$$P_{200} = 200i_{ds}^2 = 200(-0.2)^2 = 8 \text{ W}$$

$$\begin{aligned} P_{\text{absorbed}} &= P_{20\text{mA}} + P_{1k} + P_{1250} + P_{4k} + P_{2k} + P_{200} \\ &= 1.2 + 3.6 + 8 + 6.4 + 12.8 + 8 = 40 \text{ W (check)} \end{aligned}$$

P 4.20

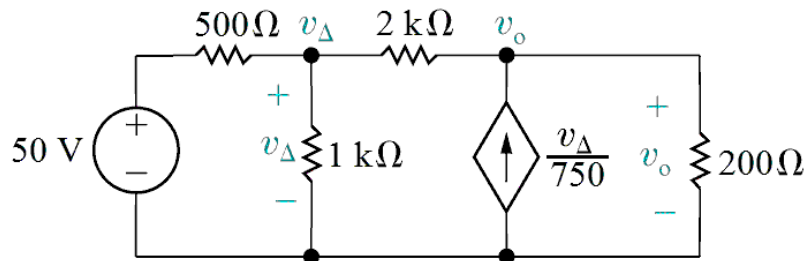

$$[a] \frac{v_{\Delta} - 50}{500} + \frac{v_{\Delta}}{1000} + \frac{v_{\Delta} - v_o}{2000} = 0$$

$$\frac{v_o - v_{\Delta}}{2000} - \frac{v_{\Delta}}{750} + \frac{v_o}{200} = 0$$

Solving,

$$v_{\Delta} = 30 \text{ V}; \quad v_o = 10 \text{ V}$$

$$[b] i_{50\text{V}} = \frac{v_{\Delta} - 50}{500} = \frac{30 - 50}{500} = -0.04 \text{ A}$$

$$P_{50\text{V}} = 50i_{50\text{V}} = 50(-0.04) = -2 \text{ W} \quad (2 \text{ W supplied})$$

$$P_{ds} = -v_o \left(\frac{v_{\Delta}}{750} \right) = -(10) \left(\frac{30}{750} \right) = -0.4 \text{ W} \quad (0.4 \text{ W supplied})$$

$$P_{\text{total}} = 2 + 0.4 = 2.4 \text{ W supplied}$$

P 4.21 [a]

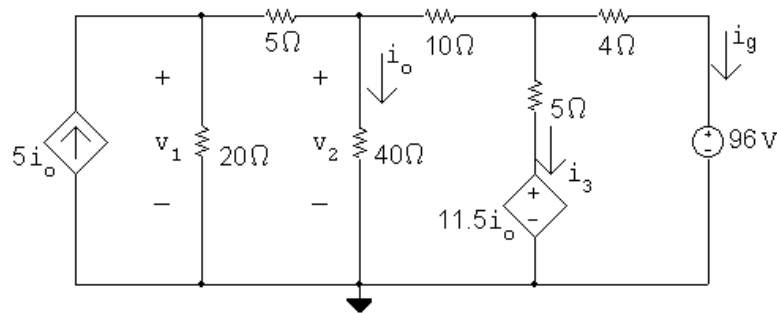

$$i_o = \frac{v_2}{40}$$

$$-5i_o + \frac{v_1}{20} + \frac{v_1 - v_2}{5} = 0 \quad \text{so} \quad 10v_1 - 13v_2 + 0v_3 = 0$$

$$\frac{v_2 - v_1}{5} + \frac{v_2}{40} + \frac{v_2 - v_3}{10} = 0 \quad \text{so} \quad -8v_1 + 13v_2 - 4v_3 = 0$$

$$\frac{v_3 - v_2}{10} + \frac{v_3 - 11.5i_o}{5} + \frac{v_3 - 96}{4} = 0 \quad \text{so} \quad 0v_1 - 63v_2 + 220v_3 = 9600$$

Solving, $v_1 = 156 \text{ V}$; $v_2 = 120 \text{ V}$; $v_3 = 78 \text{ V}$

$$[\text{b}] \quad i_o = \frac{v_2}{40} = \frac{120}{40} = 3 \text{ A}$$

$$i_3 = \frac{v_3 - 11.5i_o}{5} = \frac{78 - 11.5(3)}{5} = 8.7 \text{ A}$$

$$i_g = \frac{78 - 96}{4} = -4.5 \text{ A}$$

$$p_{5i_o} = -5i_o v_1 = -5(3)(156) = -2340 \text{ W (dev)}$$

$$p_{11.5i_o} = 11.5i_o i_3 = 11.5(3)(8.7) = 300.15 \text{ W (abs)}$$

$$p_{96V} = 96(-4.5) = -432 \text{ W (dev)}$$

$$\sum p_{\text{dev}} = 2340 + 432 = 2772 \text{ W}$$

CHECK

$$\begin{aligned} \sum p_{\text{dis}} &= \frac{156^2}{20} + \frac{(156 - 120)^2}{5} + \frac{120^2}{40} + \frac{(120 - 78)^2}{5} \\ &\quad + (8.7)^2(5) + (4.5)^2(4) + 300.15 = 2772 \text{ W} \end{aligned}$$

$$\therefore \sum p_{\text{dev}} = \sum p_{\text{dis}} = 2772 \text{ W}$$

P 4.22 [a]

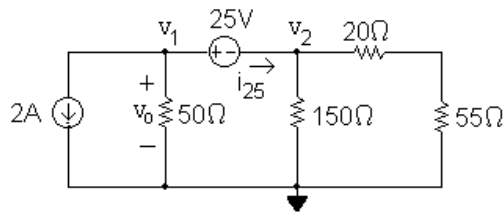

This circuit has a supernode that includes the nodes v_1 , v_2 and the 25 V source. The supernode equation is

$$2 + \frac{v_1}{50} + \frac{v_2}{150} + \frac{v_2}{75} = 0$$

The supernode constraint equation is

$$v_1 - v_2 = 25$$

Place these two equations in standard form:

$$v_1 \left(\frac{1}{50} \right) + v_2 \left(\frac{1}{150} + \frac{1}{75} \right) = -2$$

$$v_1(1) + v_2(-1) = 25$$

Solving, $v_1 = -37.5$ V and $v_2 = -62.5$ V, so $v_o = v_1 = -37.5$ V.

$$p_{2A} = (2)v_o = (2)(-37.5) = -75 \text{ W}$$

The 2 A source delivers 75 W.

[b]

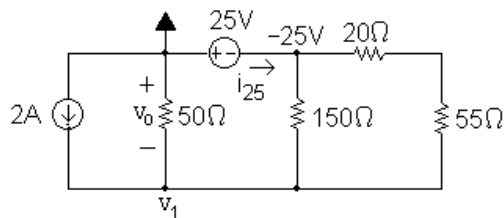

This circuit now has only one non-reference essential node where the voltage is not known – note that it is not a supernode. The KCL equation at v_1 is

$$-2 + \frac{v_1}{50} + \frac{v_1 + 25}{150} + \frac{v_1 + 25}{75} = 0$$

Solving, $v_1 = 37.5$ V so $v_o = -v_1 = -37.5$ V.

$$p_{2A} = (2)v_o = (2)(-37.5) = -75 \text{ W}$$

The 2 A source delivers 75 W.

[c] The choice of a reference node in part (b) resulted in one simple KCL equation, while the choice of a reference node in part (a) resulted in a supernode KCL equation and a second supernode constraint equation. Both methods give the same result but the choice of reference node in part (b) yielded fewer equations to solve, so is the preferred method.

P 4.23

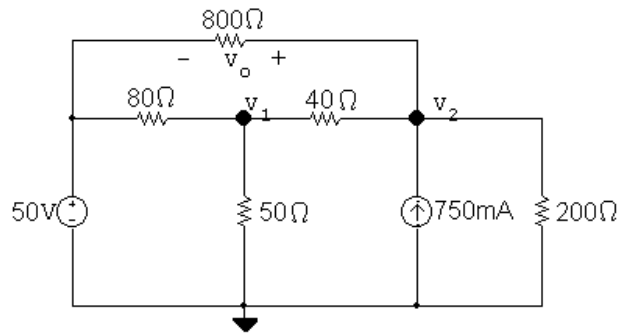

The two node voltage equations are:

$$\frac{v_1 - 50}{80} + \frac{v_1}{50} + \frac{v_1 - v_2}{40} = 0$$

$$\frac{v_2 - v_1}{40} - 0.75 + \frac{v_2}{200} + \frac{v_2 - 50}{800} = 0$$

Place these equations in standard form:

$$v_1 \left(\frac{1}{80} + \frac{1}{50} + \frac{1}{40} \right) + v_2 \left(-\frac{1}{40} \right) = \frac{50}{80}$$

$$v_1 \left(-\frac{1}{40} \right) + v_2 \left(\frac{1}{40} + \frac{1}{200} + \frac{1}{800} \right) = 0.75 + \frac{50}{800}$$

Solving, $v_1 = 34 \text{ V}$; $v_2 = 53.2 \text{ V}$.

Thus, $v_o = v_2 - 50 = 53.2 - 50 = 3.2 \text{ V}$.

POWER CHECK:

$$i_g = (50 - 34)/80 + (50 - 53.2)/800 = 196 \text{ mA}$$

$$p_{50\text{V}} = -(50)(0.196) = -9.8 \text{ W}$$

$$p_{80\Omega} = (50 - 34)^2/80 = 3.2 \text{ W}$$

$$p_{800\Omega} = (50 - 53.2)^2/800 = 12.8 \text{ mW}$$

$$p_{40\Omega} = (53.2 - 34)^2/40 = 9.216 \text{ W}$$

$$p_{50\Omega} = 34^2/50 = 23.12 \text{ W}$$

$$p_{200\Omega} = 53.2^2/200 = 14.1512 \text{ W}$$

$$p_{0.75\text{A}} = -(53.2)(0.75) = -39.9 \text{ W}$$

$$\sum p_{\text{abs}} = 3.2 + 0.0128 + 9.216 + 23.12 + 14.1512 = 49.7 \text{ W}$$

$$\sum p_{\text{del}} = 9.8 + 39.9 = 49.7 \text{ (check)}$$

P 4.24

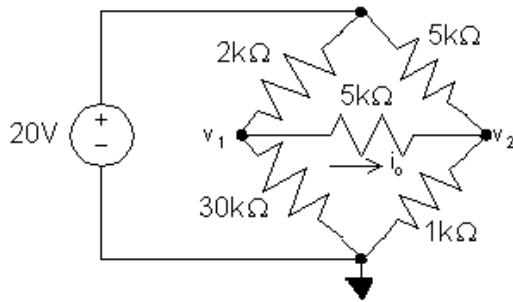

$$\frac{v_1}{30,000} + \frac{v_1 - v_2}{5000} + \frac{v_1 - 20}{2000} = 0 \quad \text{so} \quad 22v_1 - 6v_2 = 300$$

$$\frac{v_2}{1000} + \frac{v_2 - v_1}{5000} + \frac{v_2 - 20}{5000} = 0 \quad \text{so} \quad -v_1 + 7v_2 = 20$$

Solving, $v_1 = 15 \text{ V}$; $v_2 = 5 \text{ V}$

$$\text{Thus, } i_o = \frac{v_1 - v_2}{5000} = 2 \text{ mA}$$

P 4.25 [a]

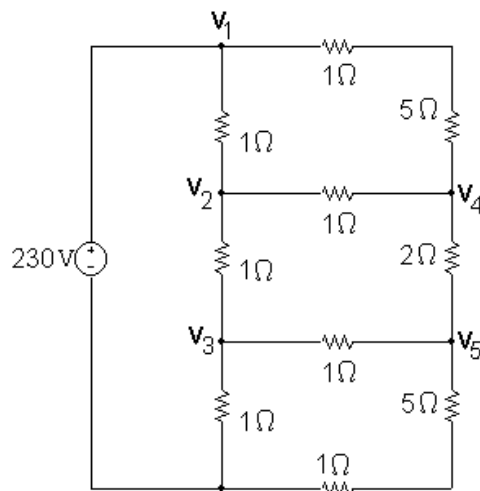

$$\frac{v_2 - 230}{1} + \frac{v_2 - v_4}{1} + \frac{v_2 - v_3}{1} = 0 \quad \text{so} \quad 3v_2 - 1v_3 - 1v_4 + 0v_5 = 230$$

$$\frac{v_3 - v_2}{1} + \frac{v_3}{1} + \frac{v_3 - v_5}{1} = 0 \quad \text{so} \quad -1v_2 + 3v_3 + 0v_4 - 1v_5 = 0$$

$$\frac{v_4 - v_2}{1} + \frac{v_4 - 230}{6} + \frac{v_4 - v_5}{2} = 0 \quad \text{so} \quad -12v_2 + 0v_3 + 20v_4 - 6v_5 = 460$$

$$\frac{v_5 - v_3}{1} + \frac{v_5}{6} + \frac{v_5 - v_4}{2} = 0 \quad \text{so} \quad 0v_2 - 12v_3 - 6v_4 + 20v_5 = 0$$

Solving, $v_2 = 150 \text{ V}$; $v_3 = 80 \text{ V}$; $v_4 = 140 \text{ V}$; $v_5 = 90 \text{ V}$

$$i_{2\Omega} = \frac{v_4 - v_5}{2} = \frac{140 - 90}{2} = 25 \text{ A}$$

$$p_{2\Omega} = (25)^2(2) = 1250 \text{ W}$$

$$\begin{aligned} \text{[b]} \quad i_{230\text{V}} &= \frac{v_1 - v_2}{1} + \frac{v_1 - v_4}{6} \\ &= \frac{230 - 150}{1} + \frac{230 - 140}{6} = 80 + 15 = 95 \text{ A} \end{aligned}$$

$$p_{230\text{V}} = (230)(95) = 21,850 \text{ W}$$

Check:

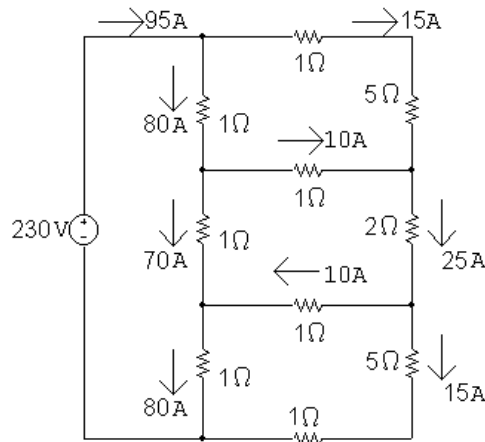

$$\begin{aligned} \sum P_{\text{dis}} &= (80)^2(1) + (70)^2(1) + (80)^2(1) + (15)^2(6) + (10)^2(1) \\ &\quad + (10)^2(1) + (25)^2(2) + (15)^2(6) = 21,850 \text{ W} \end{aligned}$$

P 4.26 Place $5v_\Delta$ inside a supernode and use the lower node as a reference. Then

$$\frac{v_\Delta - 15}{10} + \frac{v_\Delta}{2} + \frac{v_\Delta - 5v_\Delta}{20} + \frac{v_\Delta - 5v_\Delta}{40} = 0$$

$$12v_\Delta = 60; \quad v_\Delta = 5 \text{ V}$$

$$v_o = v_\Delta - 5v_\Delta = -4(5) = -20 \text{ V}$$

P 4.27 [a]

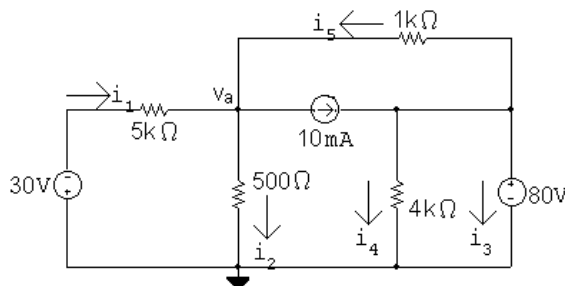

There is only one node voltage equation:

$$\frac{v_a + 30}{5000} + \frac{v_a}{500} + \frac{v_a - 80}{1000} + 0.01 = 0$$

Solving,

$$v_a + 30 + 10v_a + 5v_a - 400 + 50 = 0 \quad \text{so} \quad 16v_a = 320$$

$$\therefore v_a = 20 \text{ V}$$

Calculate the currents:

$$i_1 = (-30 - 20)/5000 = -10 \text{ mA}$$

$$i_2 = 20/500 = 40 \text{ mA}$$

$$i_4 = 80/4000 = 20 \text{ mA}$$

$$i_5 = (80 - 20)/1000 = 60 \text{ mA}$$

$$i_3 + i_4 + i_5 - 10 \text{ mA} = 0 \quad \text{so} \quad i_3 = 0.01 - 0.02 - 0.06 = -0.07 = -70 \text{ mA}$$

$$\text{[b]} \quad p_{30\text{V}} = (30)(-0.01) = -0.3 \text{ W}$$

$$p_{10\text{mA}} = (20 - 80)(0.01) = -0.6 \text{ W}$$

$$p_{80\text{V}} = (80)(-0.07) = -5.6 \text{ W}$$

$$p_{5\text{k}} = (-0.01)^2(5000) = 0.5 \text{ W}$$

$$p_{500\Omega} = (0.04)^2(500) = 0.8 \text{ W}$$

$$p_{1\text{k}} = (80 - 20)^2/(1000) = 3.6 \text{ W}$$

$$p_{4\text{k}} = (80)^2/(4000) = 1.6 \text{ W}$$

$$\sum p_{\text{abs}} = 0.5 + 0.8 + 3.6 + 1.6 = 6.5 \text{ W}$$

$$\sum p_{\text{del}} = 0.3 + 0.6 + 5.6 = 6.5 \text{ W (checks!)}$$

P 4.28

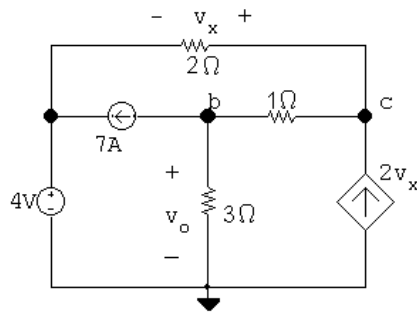

The two node voltage equations are:

$$7 + \frac{v_b}{3} + \frac{v_b - v_c}{1} = 0$$

$$-2v_x + \frac{v_c - v_b}{1} + \frac{v_c - 4}{2} = 0$$

The constraint equation for the dependent source is:

$$v_x = v_c - 4$$

Place these equations in standard form:

$$v_b \left(\frac{1}{3} + 1 \right) + v_c(-1) + v_x(0) = -7$$

$$v_b(-1) + v_c \left(1 + \frac{1}{2} \right) + v_x(-2) = \frac{4}{2}$$

$$v_b(0) + v_c(1) + v_x(-1) = 4$$

Solving, $v_c = 9 \text{ V}$, $v_x = 5 \text{ V}$, and $v_o = v_b = 1.5 \text{ V}$

P 4.29

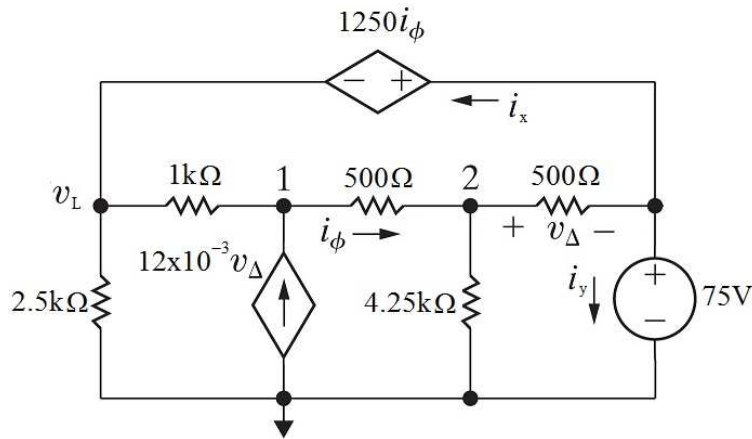

[a] The left-most node voltage is $75 - 1250i_\phi$. The right-most node voltage is 75 V . Write KCL equations at the essential nodes labeled 1 and 2.

[b] From the values given,

$$i_\phi = \frac{v_1 - v_2}{500} = \frac{105 - 85}{500} = 0.04 \text{ A}$$

$$v_\Delta = v_2 - 75 = 85 - 75 = 10 \text{ V}$$

$$v_L = 75 - (1250)(0.04) = 25 \text{ V}$$

$$i_x = \frac{v_L - v_1}{1000} + \frac{v_L}{2500} = \frac{25 - 105}{1000} + \frac{25}{2500} = -0.07 \text{ A}$$

$$i_y = \frac{v_2 - 75}{500} - i_x = \frac{85 - 75}{500} + 0.07 = 0.09 \text{ A}$$

Calculate the total power:

$$P_{\text{dstop}} = 1250i_\phi(i_x) = 1250(0.04)(-0.07) = -3.5 \text{ W}$$

$$P_{\text{dsbot}} = -v_1(12 \times 10^{-3}v_\Delta) = -(105)(12 \times 10^{-3})(10) = -12.6 \text{ W}$$

$$P_{75\text{V}} = 75i_y = 75(0.09) = 6.75 \text{ W}$$

$$P_{1k} = \frac{(v_L - v_1)^2}{1000} = \frac{(25 - 105)^2}{1000} = 6.4 \text{ W}$$

$$P_{2.5k} = \frac{v_L^2}{2500} = \frac{25^2}{2500} = 0.25 \text{ W}$$

$$P_{500\text{mid}} = 500i_\phi^2 = 500(0.04)^2 = 0.8 \text{ W}$$

$$P_{500\text{right}} = \frac{v_\Delta^2}{500} = \frac{10^2}{500} = 0.2 \text{ W}$$

$$P_{4.25k} = \frac{v_2^2}{4250} = \frac{85^2}{4250} = 1.7 \text{ W}$$

[c] $P_{\text{supplied}} = 3.5 + 12.6 = 16.1 \text{ W}$

$$P_{\text{absorbed}} = 6.75 + 6.4 + 0.25 + 0.8 + 0.2 + 1.7 = 16.1 \text{ W} = P_{\text{supplied}}$$

Therefore the analyst is correct.

P 4.30

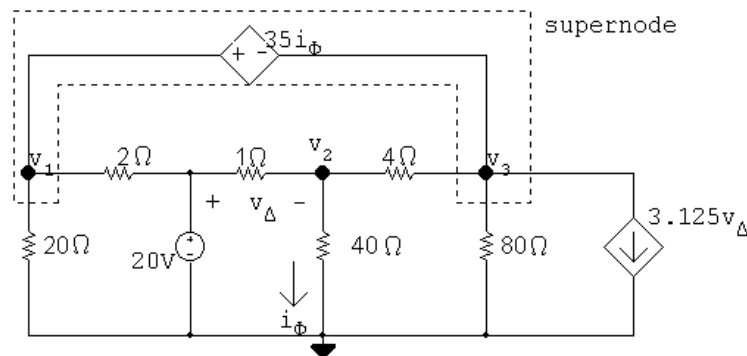

Node equations:

$$\frac{v_1}{20} + \frac{v_1 - 20}{2} + \frac{v_3 - v_2}{4} + \frac{v_3}{80} + 3.125v_\Delta = 0$$

$$\frac{v_2}{40} + \frac{v_2 - v_3}{4} + \frac{v_2 - 20}{1} = 0$$

Constraint equations:

$$v_\Delta = 20 - v_2$$

$$v_1 - 35i_\phi = v_3$$

$$i_\phi = v_2/40$$

$$\text{Solving, } v_1 = -20.25 \text{ V; } v_2 = 10 \text{ V; } v_3 = -29 \text{ V}$$

Let i_g be the current delivered by the 20 V source, then

$$i_g = \frac{20 - (20.25)}{2} + \frac{20 - 10}{1} = 30.125 \text{ A}$$

$$p_g \text{ (delivered)} = 20(30.125) = 602.5 \text{ W}$$

P 4.31 From Eq. 4.16, $i_B = v_c / (1 + \beta)R_E$

From Eq. 4.17, $i_B = (v_b - V_o) / (1 + \beta)R_E$

From Eq. 4.19,

$$\begin{aligned} i_B &= \frac{1}{(1 + \beta)R_E} \left[\frac{V_{CC}(1 + \beta)R_ER_2 + V_oR_1R_2}{R_1R_2 + (1 + \beta)R_E(R_1 + R_2)} - V_o \right] \\ &= \frac{V_{CC}R_2 - V_o(R_1 + R_2)}{R_1R_2 + (1 + \beta)R_E(R_1 + R_2)} = \frac{[V_{CC}R_2 / (R_1 + R_2)] - V_o}{[R_1R_2 / (R_1 + R_2)] + (1 + \beta)R_E} \end{aligned}$$

P 4.32 [a]

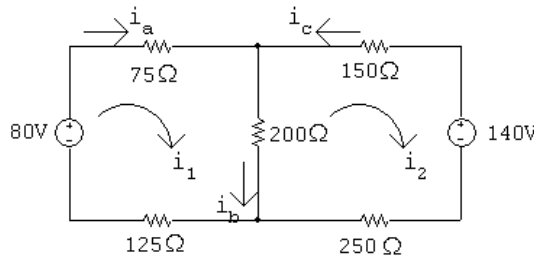

$$80 = 400i_1 - 200i_2$$

$$-140 = -200i_1 + 600i_2$$

$$\text{Solving, } i_1 = 0.1 \text{ A; } i_2 = -0.2 \text{ A}$$

$$i_a = i_1 = 0.1 \text{ A; } i_b = i_1 - i_2 = 0.3 \text{ A; } i_c = -i_2 = 0.2 \text{ A}$$

[b] If the polarity of the 140 V source is reversed, we have

$$80 = 400i_1 - 200i_2$$

$$140 = -200i_1 + 600i_2$$

$$i_1 = 0.38 \text{ A} \quad \text{and} \quad i_2 = 0.36 \text{ A}$$

$$i_a = i_1 = 0.38 \text{ A; } i_b = i_1 - i_2 = 0.02 \text{ A; } i_c = -i_2 = -0.36 \text{ A}$$

P 4.33 [a]

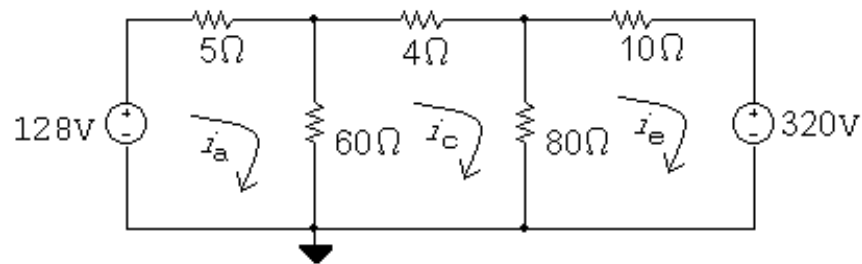

The three mesh current equations are:

$$-128 + 5i_a + 60(i_a - i_c) = 0$$

$$4i_c + 80(i_c - i_e) + 60(i_c - i_a) = 0$$

$$320 + 80(i_e - i_c) + 10i_e = 0$$

Place these equations in standard form:

$$i_a(5 + 60) + i_c(-60) + i_e(0) = 128$$

$$i_a(-60) + i_c(4 + 80 + 60) + i_e(-80) = 0$$

$$i_a(0) + i_c(-80) + i_e(80 + 10) = -320$$

Solving, $i_a = -6.8$ A; $i_c = -9.5$ A; $i_e = -12$ A

Now calculate the remaining branch currents:

$$i_b = i_a - i_c = 2.7 \text{ A}$$

$$i_d = i_c - i_e = 2.5 \text{ A}$$

[b] $p_{128V} = -(128)(-6.8) = 870.4 \text{ W (abs)}$

$$p_{320V} = (320)(-12) = -3840 \text{ W (dev)}$$

Therefore, the total power developed is 3840 W.

P 4.34 [a]

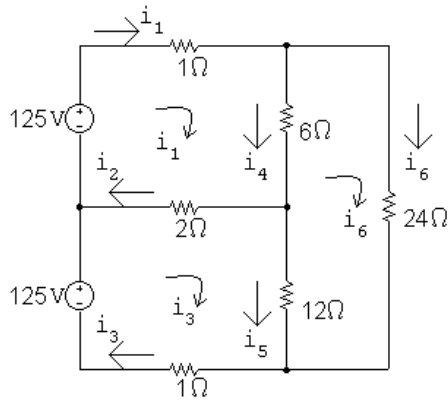

The three mesh current equations are:

$$-125 + 1i_1 + 6(i_1 - i_6) + 2(i_1 - i_3) = 0$$

$$24i_6 + 12(i_6 - i_3) + 6(i_6 - i_1) = 0$$

$$-125 + 2(i_3 - i_1) + 12(i_3 - i_6) + 1i_3 = 0$$

Place these equations in standard form:

$$i_1(1 + 6 + 2) + i_3(-2) + i_6(-6) = 125$$

$$i_1(-6) + i_3(-12) + i_6(24 + 12 + 6) = 0$$

$$i_1(-2) + i_3(2 + 12 + 1) + i_6(-12) = 125$$

Solving, $i_1 = 23.76$ A; $i_3 = 18.43$ A; $i_6 = 8.66$ A

Now calculate the remaining branch currents:

$$i_2 = i_1 - i_3 = 5.33 \text{ A}$$

$$i_4 = i_1 - i_6 = 15.10 \text{ A}$$

$$i_5 = i_3 - i_6 = 9.77 \text{ A}$$

$$[b] p_{\text{sources}} = p_{\text{top}} + p_{\text{bottom}} = -(125)(23.76) - (125)(18.43)$$

$$= -2969.58 - 2303.51 = -5273 \text{ W}$$

Thus, the power developed in the circuit is 5273 W.

Now calculate the power absorbed by the resistors:

$$p_{1\text{top}} = (23.76)^2(1) = 564.39 \text{ W}$$

$$p_2 = (5.33)^2(2) = 56.79 \text{ W}$$

$$p_{1\text{bot}} = (18.43)^2(1) = 339.59 \text{ W}$$

$$p_6 = (15.10)^2(6) = 1367.64 \text{ W}$$

$$p_{12} = (9.77)^2(12) = 1145.22 \text{ W}$$

$$p_{24} = (8.66)^2(24) = 1799.47 \text{ W}$$

The power absorbed by the resistors is

$564.39 + 56.79 + 339.59 + 1367.64 + 1145.22 + 1799.47 = 5273 \text{ W}$ so the power balances.

P 4.35

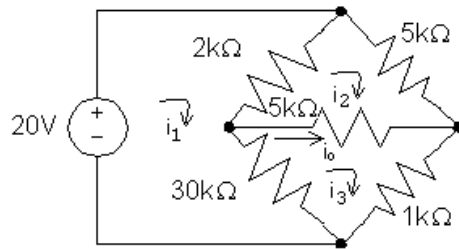

The three mesh current equations are:

$$-20 + 2000(i_1 - i_2) + 30,000(i_1 - i_3) = 0$$

$$5000i_2 + 5000(i_2 - i_3) + 2000(i_2 - i_1) = 0$$

$$1000i_3 + 30,000(i_3 - i_1) + 5000(i_3 - i_2) = 0$$

Place these equations in standard form:

$$i_1(32,000) + i_2(-2000) + i_3(-30,000) = 20$$

$$i_1(-2000) + i_2(12,000) + i_3(-5000) = 0$$

$$i_1(-30,000) + i_2(-5000) + i_3(36,000) = 0$$

Solving, $i_1 = 5.5 \text{ mA}$; $i_2 = 3 \text{ mA}$; $i_3 = 5 \text{ mA}$

Thus, $i_o = i_3 - i_2 = 2 \text{ mA}$.

P 4.36 [a]

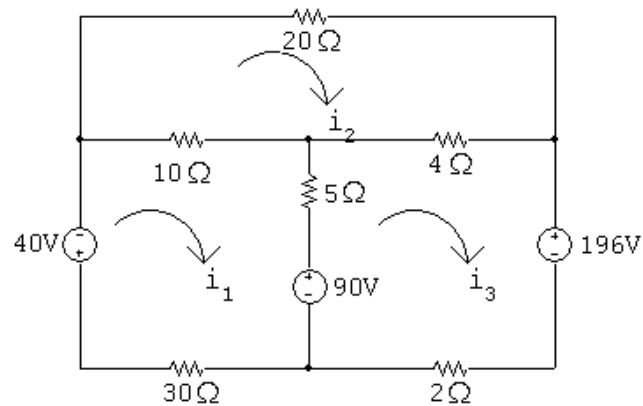

$$40 + 10(i_1 - i_2) + 5(i_1 - i_3) + 90 + 30i_1 = 0$$

$$20i_2 + 4(i_2 - i_3) + 10(i_2 - i_1) = 0$$

$$196 + 2i_3 - 90 + 5(i_3 - i_1) + 4(i_3 - i_2) = 0$$

$$\text{Solving, } i_1 = -5 \text{ A; } i_2 = -3 \text{ A; } i_3 = -13 \text{ A}$$

$$p_{40} = 40i_1 = -200 \text{ W (del)}$$

$$p_{90} = 90(i_1 - i_3) = 720 \text{ W (abs)}$$

$$p_{196} = 196i_3 = -2548 \text{ W (del)}$$

$$\therefore \sum p_{\text{dev}} = 2748 \text{ W}$$

$$\text{[b] } p_{20\Omega} = (-3)^2(20) = 180 \text{ W}$$

$$p_{10\Omega} = (2)^2(10) = 40 \text{ W}$$

$$p_{4\Omega} = (10)^2(4) = 400 \text{ W}$$

$$p_{5\Omega} = (8)^2(5) = 320 \text{ W}$$

$$p_{30\Omega} = (-5)^2(30) = 750 \text{ W}$$

$$p_{2\Omega} = (-13)^2(2) = 338 \text{ W}$$

$$\therefore \sum p_{\text{abs}} = 720 + 180 + 40 + 400 + 320 + 750 + 338 = 2748 \text{ W}$$

P 4.37 [a]

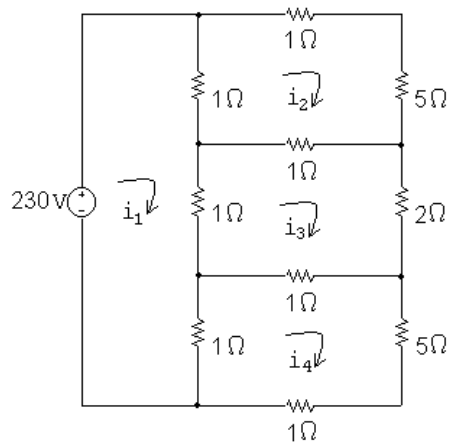

The four mesh current equations are:

$$-230 + 1(i_1 - i_2) + 1(i_1 - i_3) + 1(i_1 - i_4) = 0$$

$$6i_2 + 1(i_2 - i_3) + 1(i_2 - i_1) = 0$$

$$2i_3 + 1(i_3 - i_4) + 1(i_3 - i_1) + 1(i_3 - i_2) = 0$$

$$6i_4 + 1(i_4 - i_1) + 1(i_4 - i_3) = 0$$

Place these equations in standard form:

$$i_1(3) + i_2(-1) + i_3(-1) + i_4(-1) = 230$$

$$i_1(-1) + i_2(8) + i_3(-1) + i_4(0) = 0$$

$$i_1(-1) + i_2(-1) + i_3(5) + i_4(-1) = 0$$

$$i_1(-1) + i_2(0) + i_3(-1) + i_4(8) = 0$$

Solving, $i_1 = 95$ A; $i_2 = 15$ A; $i_3 = 25$ A; $i_4 = 15$ A

The power absorbed by the 5Ω resistor is

$$p_5 = i_3^2(2) = (25)^2(2) = 1250 \text{ W}$$

[b] $p_{230} = -(230)i_1 = -(230)(95) = -21,850 \text{ W}$

P 4.38

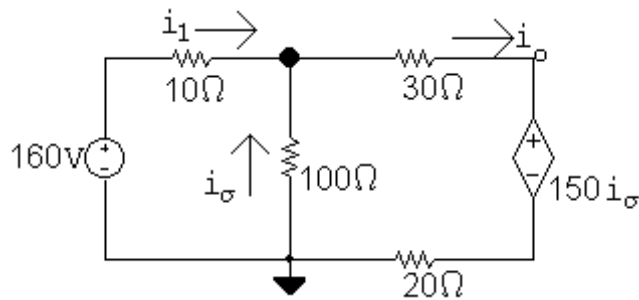

$$-160 + 10i_1 + 100(i_1 - i_o) = 0$$

$$30i_o + 150i_\sigma + 20i_o + 100i_\sigma = 0$$

$$i_\sigma = i_o - i_1$$

Solving,

$$i_1 = 6 \text{ A}; \quad i_o = 5 \text{ A}; \quad i_\sigma = -1 \text{ A}$$

$$P_{ds} = (150i_\sigma)i_o = 150(-1)(5) = -750 \text{ W}$$

Thus, 750 W is delivered by the dependent source.

P 4.39

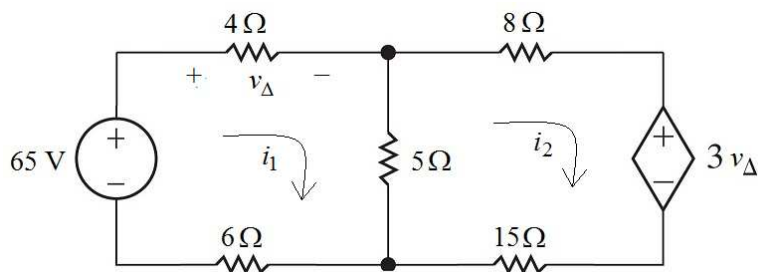

$$-65 + 4i_1 + 5(i_1 - i_2) + 6i_1 = 0$$

$$8i_2 + 3v_\Delta + 15i_2 + 5(i_2 - i_1) = 0$$

$$v_\Delta = 4i_1$$

$$\text{Solving, } i_1 = 4 \text{ A} \quad i_2 = -1 \text{ A} \quad v_\Delta = 16 \text{ V}$$

$$p_{15\Omega} = (-1)^2(15) = 15 \text{ W}$$

P 4.40

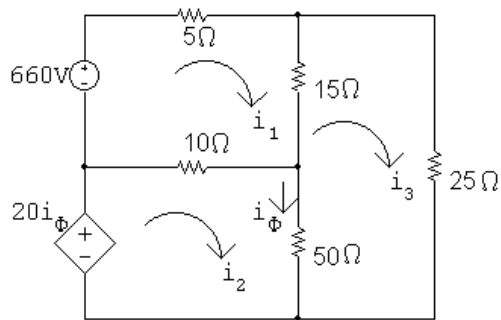

$$660 = 30i_1 - 10i_2 - 15i_3$$

$$20i_\phi = -10i_1 + 60i_2 - 50i_3$$

$$0 = -15i_1 - 50i_2 + 90i_3$$

$$i_\phi = i_2 - i_3$$

$$\text{Solving, } i_1 = 42 \text{ A; } \quad i_2 = 27 \text{ A; } \quad i_3 = 22 \text{ A; } \quad i_\phi = 5 \text{ A}$$

$$20i_\phi = 100 \text{ V}$$

$$p_{20i_\phi} = -100i_2 = -100(27) = -2700 \text{ W}$$

$$\therefore p_{20i_\phi} \text{ (developed)} = 2700 \text{ W}$$

CHECK:

$$p_{660\text{V}} = -660(42) = -27,720 \text{ W (dev)}$$

$$\therefore \sum P_{\text{dev}} = 27,720 + 2700 = 30,420 \text{ W}$$

$$\begin{aligned} \sum P_{\text{dis}} &= (42)^2(5) + (22)^2(25) + (20)^2(15) + (5)^2(50) + \\ &\quad (15)^2(10) \\ &= 30,420 \text{ W} \end{aligned}$$

P 4.41 [a]

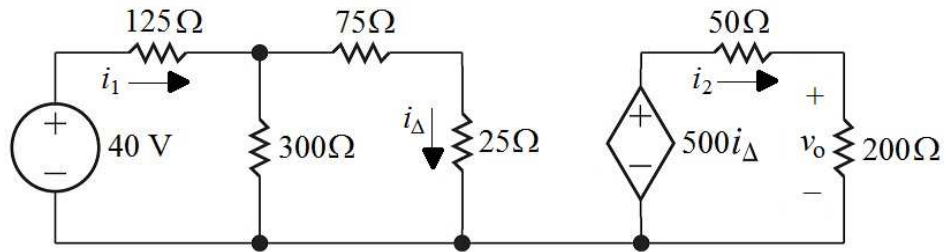

$$40 = 125i_1 + 300(i_1 - i_\Delta)$$

$$0 = 75i_\Delta + 25i_\Delta + 300(i_\Delta - i_1)$$

$$0 = 50i_2 + 200i_2 - 500i_\Delta$$

Solving, $i_1 = 0.2 \text{ A}$; $i_2 = 0.3 \text{ A}$; $i_\Delta = 0.15 \text{ A}$

$$v_o = 200i_2 = 200(0.3) = 60 \text{ V}$$

[b] $p_{ds} = -(500i_\Delta)i_2 = -500(0.15)(0.3) = -22.5 \text{ W}$

$\therefore p_{ds} \text{ (delivered)} = 22.5 \text{ W}$

P 4.42

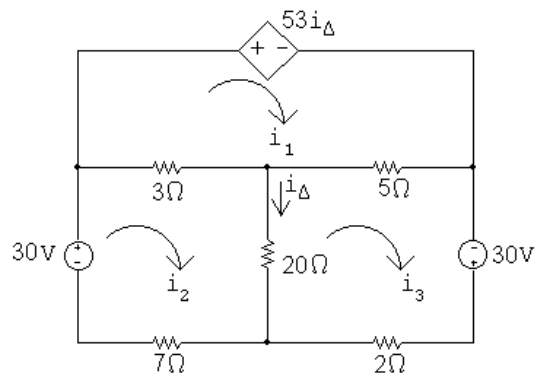

Mesh equations:

$$53i_\Delta + 8i_1 - 3i_2 - 5i_3 = 0$$

$$0i_\Delta - 3i_1 + 30i_2 - 20i_3 = 30$$

$$0i_\Delta - 5i_1 - 20i_2 + 27i_3 = 30$$

Constraint equations:

$$i_\Delta = i_2 - i_3$$

$$\text{Solving, } i_1 = 110 \text{ A; } \quad i_2 = 52 \text{ A; } \quad i_3 = 60 \text{ A; } \quad i_\Delta = -8 \text{ A}$$

$$p_{\text{depsource}} = 53i_\Delta i_1 = (53)(-8)(110) = -46,640 \text{ W}$$

Therefore, the dependent source is developing 46,640 W.

CHECK:

$$p_{30\text{V}} = -30i_2 = -1560 \text{ W (left source)}$$

$$p_{30\text{V}} = -30i_3 = -1800 \text{ W (right source)}$$

$$\sum p_{\text{dev}} = 46,640 + 1560 + 1800 = 50 \text{ kW}$$

$$p_{3\Omega} = (110 - 52)^2(3) = 10,092 \text{ W}$$

$$p_{5\Omega} = (110 - 60)^2(5) = 12,500 \text{ W}$$

$$p_{20\Omega} = (-8)^2(20) = 1280 \text{ W}$$

$$p_{7\Omega} = (52)^2(7) = 18,928 \text{ W}$$

$$p_{2\Omega} = (60)^2(2) = 7200 \text{ W}$$

$$\sum p_{\text{diss}} = 10,092 + 12,500 + 1280 + 18,928 + 7200 = 50 \text{ kW}$$

P 4.43 [a]

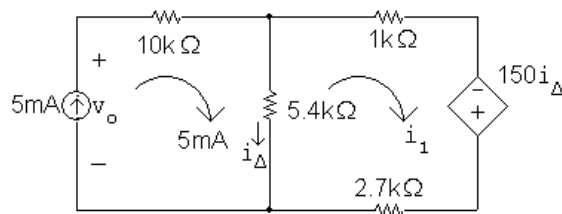

The mesh current equation for the right mesh is:

$$5400(i_1 - 0.005) + 3700i_1 - 150(0.005 - i_1) = 0$$

$$\text{Solving, } \quad 9250i_1 = 27.75 \quad \therefore \quad i_1 = 3 \text{ mA}$$

$$\text{Then, } \quad i_\Delta = 5 - 3 = 2 \text{ mA}$$

$$\text{[b] } v_o = (0.005)(10,000) + (5400)(0.002) = 60.8 \text{ V}$$

$$p_{5\text{mA}} = -(60.8)(0.005) = -304 \text{ mW}$$

Thus, the 5 mA source delivers 304 mW

$$\text{[c] } p_{\text{dep source}} = -150i_\Delta i_1 = (-150)(0.002)(0.003) = -0.9 \text{ mW}$$

The dependent source delivers 0.9 mW.

P 4.44

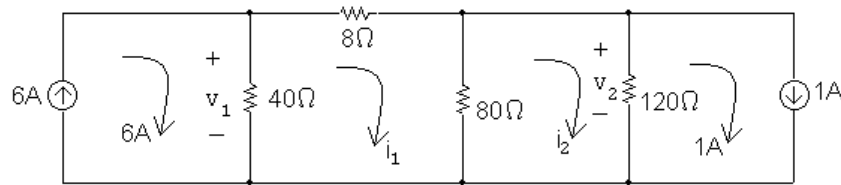

Mesh equations:

$$128i_1 - 80i_2 = 240$$

$$-80i_1 + 200i_2 = 120$$

Solving,

$$i_1 = 3 \text{ A}; \quad i_2 = 1.8 \text{ A}$$

Therefore,

$$v_1 = 40(6 - 3) = 120 \text{ V}; \quad v_2 = 120(1.8 - 1) = 96 \text{ V}$$

P 4.45 [a]

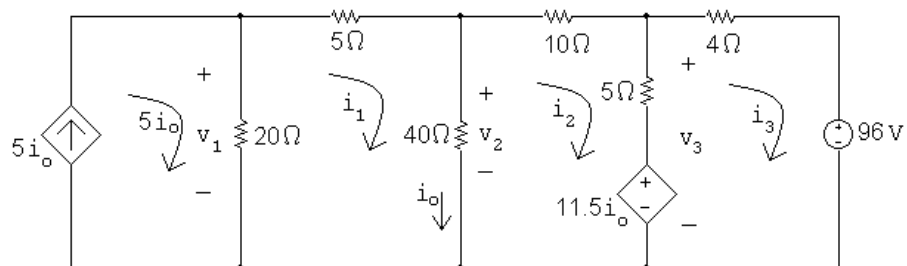

Mesh equations:

$$65i_1 - 40i_2 + 0i_3 - 100i_o = 0$$

$$-40i_1 + 55i_2 - 5i_3 + 11.5i_o = 0$$

$$0i_1 - 5i_2 + 9i_3 - 11.5i_o = 0$$

$$-1i_1 + 1i_2 + 0i_3 + 1i_o = 0$$

Solving,

$$i_1 = 7.2 \text{ A}; \quad i_2 = 4.2 \text{ A}; \quad i_3 = -4.5 \text{ A}; \quad i_o = 3 \text{ A}$$

Therefore,

$$v_1 = 20[5(3) - 7.2] = 156 \text{ V}; \quad v_2 = 40(7.2 - 4.2) = 120 \text{ V}$$

$$v_3 = 5(4.2 + 4.5) + 11.5(3) = 78 \text{ V}$$

$$[b] p_{5i_o} = -5i_o v_1 = -5(3)(156) = -2340 \text{ W}$$

$$p_{11.5i_o} = 11.5i_o(i_2 - i_3) = 11.5(3)(4.2 + 4.5) = 300.15 \text{ W}$$

$$p_{96V} = 96i_3 = 96(-4.5) = -432 \text{ W}$$

Thus, the total power dissipated in the circuit, which equals the total power developed in the circuit is $2340 + 432 = 2772 \text{ W}$.

P 4.46

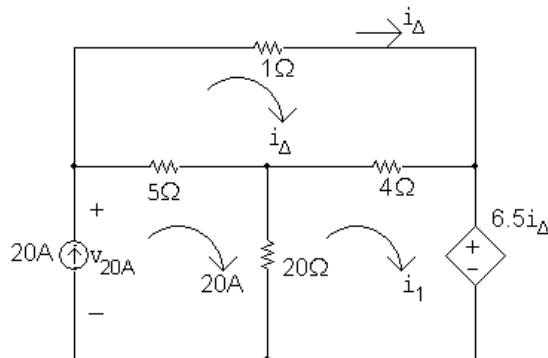

Mesh equations:

$$10i_{\Delta} - 4i_1 = 0$$

$$-4i_{\Delta} + 24i_1 + 6.5i_{\Delta} = 400$$

$$\text{Solving, } i_1 = 15 \text{ A; } i_{\Delta} = 16 \text{ A}$$

$$v_{20A} = 1i_{\Delta} + 6.5i_{\Delta} = 7.5(16) = 120 \text{ V}$$

$$p_{20A} = -20v_{20A} = -(20)(120) = -2400 \text{ W (del)}$$

$$p_{6.5i_{\Delta}} = 6.5i_{\Delta}i_1 = (6.5)(16)(15) = 1560 \text{ W (abs)}$$

Therefore, the independent source is developing 2400 W, all other elements are absorbing power, and the total power developed is thus 2400 W.

CHECK:

$$p_{1\Omega} = (16)^2(1) = 256 \text{ W}$$

$$p_{5\Omega} = (20 - 16)^2(5) = 80 \text{ W}$$

$$p_{4\Omega} = (1)^2(4) = 4 \text{ W}$$

$$p_{20\Omega} = (20 - 15)^2(20) = 500 \text{ W}$$

$$\sum p_{\text{abs}} = 1560 + 256 + 80 + 4 + 500 = 2400 \text{ W (CHECKS)}$$

P 4.47

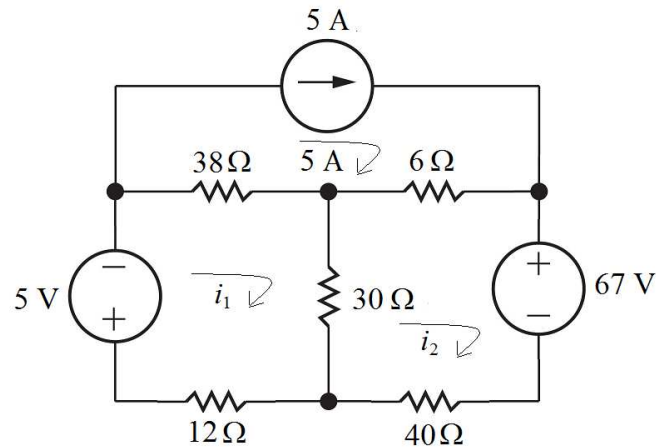

$$5 + 38(i_1 - 5) + 30(i_1 - i_2) + 12i_1 = 0$$

$$67 + 40i_2 + 30(i_2 - i_1) + 6(i_2 - 5) = 0$$

Solving, $i_1 = 2.5 \text{ A}$; $i_2 = 0.5 \text{ A}$

$$\begin{aligned} \text{[a]} \quad v_{5\text{A}} &= 38(2.5 - 5) + 6(0.5 - 5) \\ &= -122 \text{ V} \end{aligned}$$

$$p_{5\text{A}} = 5v_{5\text{A}} = 5(-122) = -610 \text{ W}$$

Therefore, the 5 A source delivers 610 W.

$$\text{[b]} \quad p_{5\text{V}} = 5(2.5) = 12.5 \text{ W}$$

$$p_{67\text{V}} = 67(0.5) = 33.5 \text{ W}$$

Therefore, only the current source delivers power and the total power delivered is 610 W.

$$\begin{aligned} \text{[c]} \quad \sum p_{\text{resistors}} &= (2.5)^2(38) + (4.5)^2(6) + (2)^2(30) + (2.5)^2(12) + (0.5)^2(40) \\ &= 564 \text{ W} \end{aligned}$$

$$\sum p_{\text{abs}} = 564 + 12.5 + 33.5 = 610 \text{ W} = \sum p_{\text{del}} \text{ (CHECKS)}$$

P 4.48 [a]

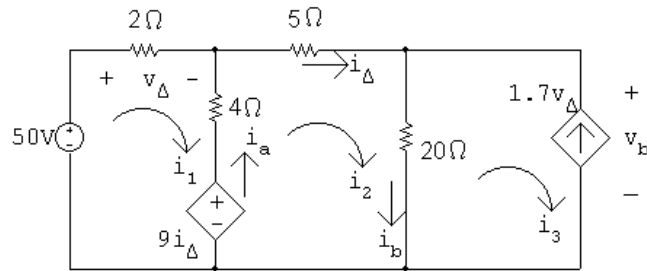

Mesh equations:

$$-50 + 6i_1 - 4i_2 + 9i_\Delta = 0$$

$$-9i_\Delta - 4i_1 + 29i_2 - 20i_3 = 0$$

Constraint equations:

$$i_\Delta = i_2; \quad i_3 = -1.7v_\Delta; \quad v_\Delta = 2i_1$$

$$\text{Solving, } i_1 = -5 \text{ A}; \quad i_2 = 16 \text{ A}; \quad i_3 = 17 \text{ A}; \quad v_\Delta = -10 \text{ V}$$

$$9i_\Delta = 9(16) = 144 \text{ V}$$

$$i_a = i_2 - i_1 = 21 \text{ A}$$

$$i_b = i_2 - i_3 = -1 \text{ A}$$

$$v_b = 20i_b = -20 \text{ V}$$

$$p_{50\text{V}} = -50i_1 = 250 \text{ W (absorbing)}$$

$$p_{9i_\Delta} = -i_a(9i_\Delta) = -(21)(144) = -3024 \text{ W (delivering)}$$

$$p_{1.7\text{V}} = -1.7v_\Delta v_b = i_3 v_b = (17)(-20) = -340 \text{ W (delivering)}$$

$$[\text{b}] \sum P_{\text{dev}} = 3024 + 340 = 3364 \text{ W}$$

$$\begin{aligned} \sum P_{\text{dis}} &= 250 + (-5)^2(2) + (21)^2(4) + (16)^2(5) + (-1)^2(20) \\ &= 3364 \text{ W} \end{aligned}$$

P 4.49

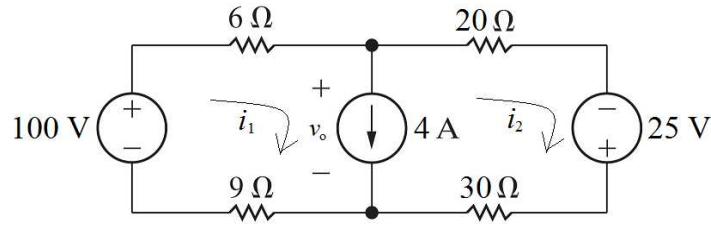

$$-100 + 6i_1 + 20i_2 - 25 + 30i_2 + 9i_1 = 0; \quad i_1 - i_2 = 4$$

Solving, $i_1 = 5 \text{ A}$; $i_2 = 1 \text{ A}$

$$p_{100\text{V}} = -100i_1 = -500 \text{ W (delivered)}$$

$$p_{6\Omega} = (5)^2(6) = 150 \text{ W}$$

$$p_{9\Omega} = (5)^2(9) = 225 \text{ W}$$

$$p_{20\Omega} = (1)^2(20) = 20 \text{ W}$$

$$p_{30\Omega} = (1)^2(30) = 30 \text{ W}$$

$$v_o = 20(1) - 25 + 30(1) = 25 \text{ V}$$

$$p_{4\text{A}} = 4v_o = 100 \text{ W}$$

$$p_{25\text{V}} = -25i_2 = -25 \text{ W (delivered)}$$

$$\sum p_{\text{dev}} = 150 + 225 + 20 + 30 + 100 = 525 \text{ W}$$

$$\sum p_{\text{diss}} = -500 - 25 = -525 \text{ W}$$

Thus the total power dissipated is 525 W.

P 4.50 [a] Summing around the supermesh used in the solution to Problem 4.49 gives

$$-67.5 + 6i_1 + 20i_2 - 25 + 30i_2 + 9i_1 = 0; \quad i_1 - i_2 = 4$$

$$\therefore i_1 = 4.5 \text{ A}; \quad i_2 = 0.5 \text{ A}$$

$$p_{67.5\text{V}} = -67.5(4.5) = -303.75 \text{ W (del)}$$

$$v_o = 20(0.5) - 25 + 30(0.5) = 0 \text{ V}$$

$$p_{4\text{A}} = 4v_o = 0 \text{ W}$$

$$p_{25\text{V}} = -25i_2 = -12.5 \text{ W (del)}$$

$$\sum p_{\text{diss}} = (4.5)^2(6 + 9) + (0.5)^2(20 + 30) = 316.25 \text{ W}$$

$$\sum p_{\text{dev}} = 303.75 + 0 + 12.5 = 316.25 \text{ W} = \sum p_{\text{diss}}$$

[b] With 4 A current source replaced with a short circuit

$$15i_1 = 67.5; \quad 50i_2 = 25$$

Solving,

$$i_1 = 4.5 \text{ A}, \quad i_2 = 0.5 \text{ A}$$

$$\therefore \sum P_{\text{sources}} = -(67.5)(4.5) - (25)(0.5) = -316.25 \text{ W}$$

[c] A 4 A source with zero terminal voltage is equivalent to a short circuit carrying 4 A.

[d] With the new value of the right-hand source, we want $v_o = 0$ but the current in the middle branch must still equal 4 A.

KVL left:

$$-100 + 6i_1 + 0 + 9i_1 = 0 \quad \text{so} \quad i_1 = 6.667 \text{ A}$$

$$i_1 - i_2 = 4 \quad \text{so} \quad i_2 = i_1 - 4 = 2.667 \text{ A}$$

KVL right:

$$20i_2 - V_2 + 30i_2 + 0 = 0 \quad \text{so} \quad V_2 = 50i_2 = 133.333 \text{ V}$$

To check these results, sum around the supermesh with the value of the source on the right as 133.333 V,

$$-100 + 6i_1 + 20i_2 - 133.333 + 30i_2 + 9i_1 = 0; \quad i_1 - i_2 = 4$$

Solving,

$$i_1 = 6.667 \text{ A}; \quad i_2 = 2.667 \text{ A}$$

Therefore,

$$v_o = 20i_2 - 133.333 + 30i_2 = 0$$

Thus,

$$P_{4\text{A}} = 4v_o = 0 \text{ (checks)}$$

P 4.51 [a]

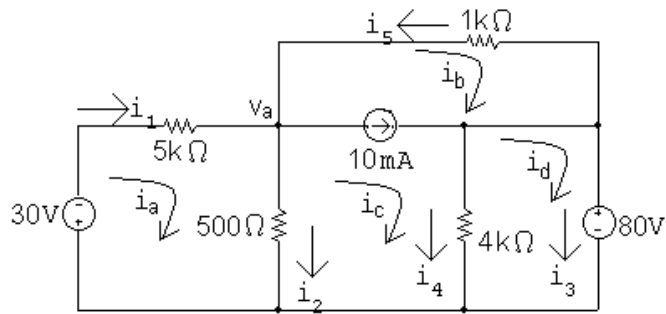

Supermesh equations:

$$1000i_b + 4000(i_c - i_d) + 500(i_c - i_a) = 0$$

$$i_c - i_b = 0.01$$

Two remaining mesh equations:

$$5500i_a - 500i_c = -30$$

$$4000i_d - 4000i_c = -80$$

In standard form,

$$-500i_a + 1000i_b + 4500i_c - 4000i_d = 0$$

$$0i_a - 1i_b + 1i_c + 0i_d = 0.01$$

$$5500i_a + 0i_b - 500i_c + 0i_d = -30$$

$$0i_a + 0i_b - 4000i_c + 4000i_d = -80$$

Solving:

$$i_a = -10 \text{ mA}; \quad i_b = -60 \text{ mA}; \quad i_c = -50 \text{ mA}; \quad i_d = -70 \text{ mA}$$

Then,

$$i_1 = i_a = -10 \text{ mA}; \quad i_2 = i_a - i_c = 40 \text{ mA}; \quad i_3 = i_d = -70 \text{ mA}$$

$$[b] \quad p_{\text{sources}} = 30(-0.01) + [1000(-0.06)](0.01) + 80(-0.07) = -6.5 \text{ W}$$

$$p_{\text{resistors}} = 1000(0.06)^2 + 5000(0.01)^2 + 500(0.04)^2 \\ + 4000(-0.05 + 0.07)^2 = 6.5 \text{ W}$$

P 4.52 [a]

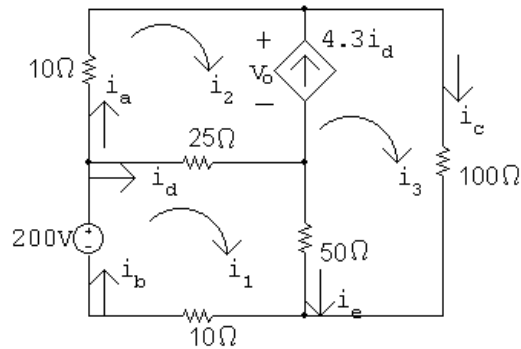

$$200 = 85i_1 - 25i_2 - 50i_3$$

$$0 = -75i_1 + 35i_2 + 150i_3 \quad (\text{supermesh})$$

$$i_3 - i_2 = 4.3(i_1 - i_2)$$

$$\text{Solving, } i_1 = 4.6 \text{ A; } \quad i_2 = 5.7 \text{ A; } \quad i_3 = 0.97 \text{ A}$$

$$i_a = i_2 = 5.7 \text{ A; } \quad i_b = i_1 = 4.6 \text{ A}$$

$$i_c = i_3 = 0.97 \text{ A; } \quad i_d = i_1 - i_2 = -1.1 \text{ A}$$

$$i_e = i_1 - i_3 = 3.63 \text{ A}$$

$$[\text{b}] \quad 10i_2 + v_o + 25(i_2 - i_1) = 0$$

$$\therefore v_o = -57 - 27.5 = -84.5 \text{ V}$$

$$p_{4.3i_d} = -v_o(4.3i_d) = -(-84.5)(4.3)(-1.1) = -399.685 \text{ W (dev)}$$

$$p_{200\text{V}} = -200(4.6) = -920 \text{ W (dev)}$$

$$\sum P_{\text{dev}} = 1319.685 \text{ W}$$

$$\begin{aligned} \sum P_{\text{dis}} &= (5.7)^2(10) + (1.1)^2(25) + (0.97)^2(100) + (4.6)^2(10) + \\ &\quad (3.63)^2(50) \\ &= 1319.685 \text{ W} \end{aligned}$$

$$\therefore \sum P_{\text{dev}} = \sum P_{\text{dis}} = 1319.685 \text{ W}$$

P 4.53 [a]

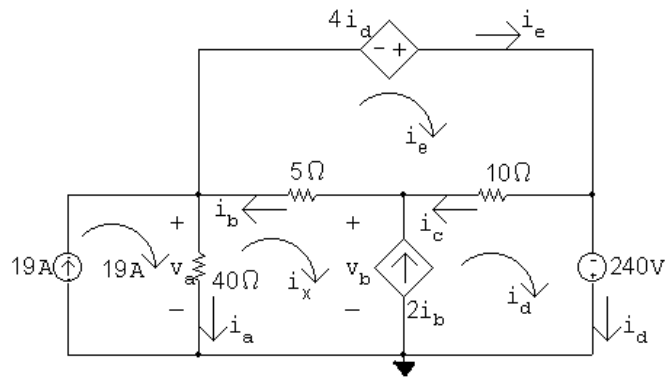

$$-4i_d + 10(i_e - i_d) + 5(i_e - i_x) = 0$$

$$5(i_x - i_e) + 10(i_d - i_e) - 240 + 40(i_x - 19) = 0$$

$$i_d - i_x = 2i_b = 2(i_e - i_x)$$

Solving, $i_d = 10 \text{ A}$; $i_e = 18 \text{ A}$; $i_x = 26 \text{ A}$

$$i_a = 19 - i_x = -7 \text{ A}; \quad i_b = i_e - i_x = -8 \text{ A}; \quad i_c = i_e - i_d = 8 \text{ A};$$

[b] $v_a = 40i_a = -280 \text{ V}$; $v_b = 5i_b + 40i_a = -320 \text{ V}$

$$p_{19\text{A}} = -19v_a = 5320 \text{ W}$$

$$p_{4i_d} = -4i_d i_e = -720 \text{ W}$$

$$p_{2i_b} = -2i_b v_b = -5120 \text{ W}$$

$$p_{240\text{V}} = -240i_d = -2400 \text{ W}$$

$$p_{40\Omega} = (7)^2(40) = 1960 \text{ W} =$$

$$p_{5\Omega} = (8)^2(5) = 320 \text{ W}$$

$$p_{10\Omega} = (8)^2(10) = 640 \text{ W}$$

$$\sum P_{\text{gen}} = 720 + 5120 + 2400 = 8240 \text{ W}$$

$$\sum P_{\text{diss}} = 5320 + 1960 + 320 + 640 = 8240 \text{ W}$$

P 4.54 [a] There are three unknown node voltages and only two unknown mesh currents. Use the mesh current method to minimize the number of simultaneous equations.

[b]

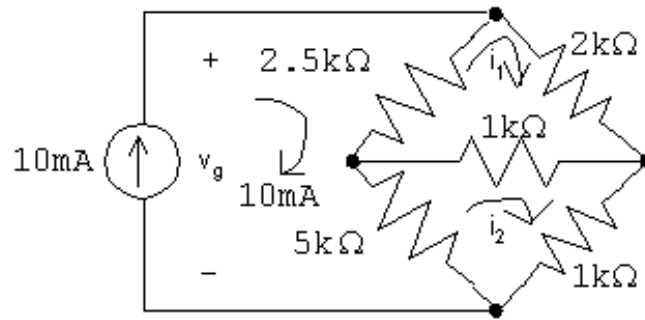

The mesh current equations:

$$2500(i_1 - 0.01) + 2000i_1 + 1000(i_1 - i_2) = 0$$

$$5000(i_2 - 0.01) + 1000(i_2 - i_1) + 1000i_2 = 0$$

Place the equations in standard form:

$$i_1(2500 + 2000 + 1000) + i_2(-1000) = 25$$

$$i_1(-1000) + i_2(5000 + 1000 + 1000) = 50$$

Solving, $i_1 = 6 \text{ mA}$; $i_2 = 8 \text{ mA}$

Find the power in the $1 \text{ k}\Omega$ resistor:

$$i_{1k} = i_1 - i_2 = -2 \text{ mA}$$

$$p_{1k} = (-0.002)^2(1000) = 4 \text{ mW}$$

[c] No, the voltage across the 10 A current source is readily available from the mesh currents, and solving two simultaneous mesh-current equations is less work than solving three node voltage equations.

[d] $v_g = 2000i_1 + 1000i_2 = 12 + 8 = 20 \text{ V}$

$$p_{10\text{mA}} = -(20)(0.01) = -200 \text{ mW}$$

Thus the 10 mA source develops 200 mW .

P 4.55 [a] There are three unknown node voltages and three unknown mesh currents, so the number of simultaneous equations required is the same for both methods. The node voltage method has the advantage of having to solve the three simultaneous equations for one unknown voltage provided the connection at either the top or bottom of the circuit is used as the reference node. Therefore recommend the node voltage method.

[b]

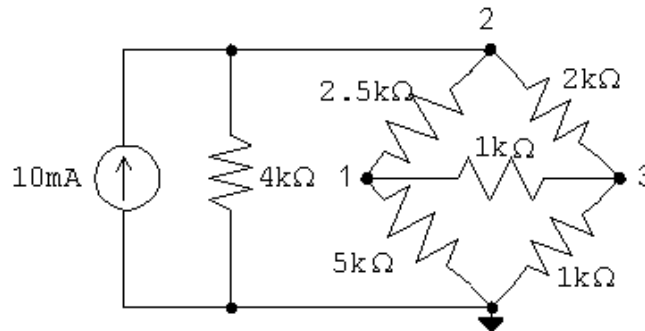

The node voltage equations are:

$$\frac{v_1}{5000} + \frac{v_1 - v_2}{2500} + \frac{v_1 - v_3}{1000} = 0$$

$$-0.01 + \frac{v_2}{4000} + \frac{v_2 - v_1}{2500} + \frac{v_2 - v_3}{2000} = 0$$

$$\frac{v_3 - v_1}{1000} + \frac{v_3 - v_2}{2000} + \frac{v_3}{1000} = 0$$

Put the equations in standard form:

$$v_1 \left(\frac{1}{5000} + \frac{1}{2500} + \frac{1}{1000} \right) + v_2 \left(-\frac{1}{2500} \right) + v_3 \left(-\frac{1}{1000} \right) = 0$$

$$v_1 \left(-\frac{1}{2500} \right) + v_2 \left(\frac{1}{4000} + \frac{1}{2500} + \frac{1}{2000} \right) + v_3 \left(-\frac{1}{2000} \right) = 0.01$$

$$v_1 \left(-\frac{1}{1000} \right) + v_2 \left(-\frac{1}{2000} \right) + v_3 \left(\frac{1}{2000} + \frac{1}{1000} + \frac{1}{1000} \right) = 0$$

Solving, $v_1 = 6.67 \text{ V}$; $v_2 = 13.33 \text{ V}$; $v_3 = 5.33 \text{ V}$

$$p_{10\text{m}} = -(13.33)(0.01) = -133.33 \text{ mW}$$

Therefore, the 10 mA source is developing 133.33 mW

P 4.56 [a] The node voltage method requires summing the currents at two supernodes in terms of four node voltages and using two constraint equations to reduce the system of equations to two unknowns. If the connection at the bottom of the circuit is used as the reference node, then the voltages controlling the dependent sources are node voltages. This makes it easy to formulate the constraint equations. The current in the 20 V source is obtained by summing the currents at either terminal of the source.

The mesh current method requires summing the voltages around the two meshes not containing current sources in terms of four mesh currents. In addition the voltages controlling the dependent sources must be expressed in terms of the mesh currents. Thus the constraint equations are more complicated, and the reduction to two equations and two unknowns involves more algebraic manipulation. The current in the 20 V source is found by subtracting two mesh currents.

Because the constraint equations are easier to formulate in the node

voltage method, it is the preferred approach.

[b]

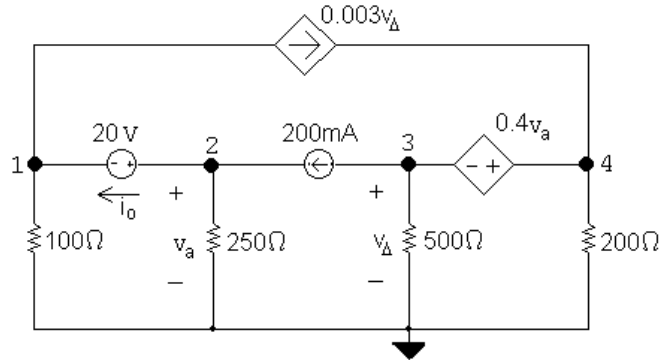

Node voltage equations:

$$\frac{v_1}{100} + 0.003v_\Delta + \frac{v_2}{250} - 0.2 = 0$$

$$0.2 + \frac{v_3}{100} + \frac{v_4}{200} - 0.003v_\Delta = 0$$

Constraints:

$$v_2 = v_a; \quad v_3 = v_\Delta; \quad v_4 - v_3 = 0.4v_a; \quad v_2 - v_1 = 20$$

$$\text{Solving, } v_1 = 24 \text{ V}; \quad v_2 = 44 \text{ V}; \quad v_3 = -72 \text{ V}; \quad v_4 = -54 \text{ V}.$$

$$i_o = 0.2 - \frac{v_2}{250} = 24 \text{ mA}$$

$$p_{20\text{V}} = 20(0.024) = 480 \text{ mW}$$

Thus, the 20 V source absorbs 480 mW.

P 4.57 [a] The mesh-current method does not directly involve the voltage drop across the 40 mA source. Instead, use the node-voltage method and choose the reference node so that a node voltage is identical to the voltage across the 40 mA source.

[b]

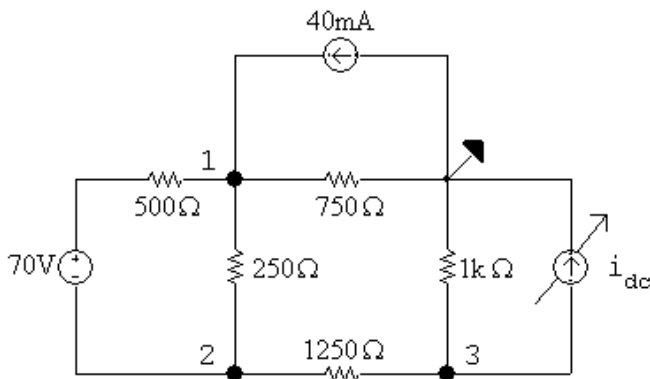

Since the 40 mA source is developing 0 W, v_1 must be 0 V.

Since v_1 is known, we can sum the currents away from node 1 to find v_2 ; thus:

$$\frac{0 - (70 + v_2)}{500} + \frac{0 - v_2}{250} + \frac{0}{750} - 0.04 = 0$$

$$\therefore v_2 = -30 \text{ V}$$

Now that we know v_2 we sum the currents away from node 2 to find v_3 ; thus:

$$\frac{v_2 + 70 - 0}{500} + \frac{v_2 - 0}{250} + \frac{v_2 - v_3}{1250} = 0$$

$$\therefore v_3 = -80 \text{ V}$$

Now that we know v_3 we sum the currents away from node 3 to find i_{dc} ; thus:

$$\frac{v_3}{1000} + \frac{v_3 - v_2}{1250} + i_{dc} = 0$$

$$\therefore i_{dc} = 0.12 = 120 \text{ mA}$$

- P 4.58 [a] If the mesh-current method is used, then the value of the lower left mesh current is $i_o = 0$. This shortcut will simplify the set of KVL equations. The node-voltage method has no equivalent simplifying shortcut, so the mesh-current method is preferred.

[b]

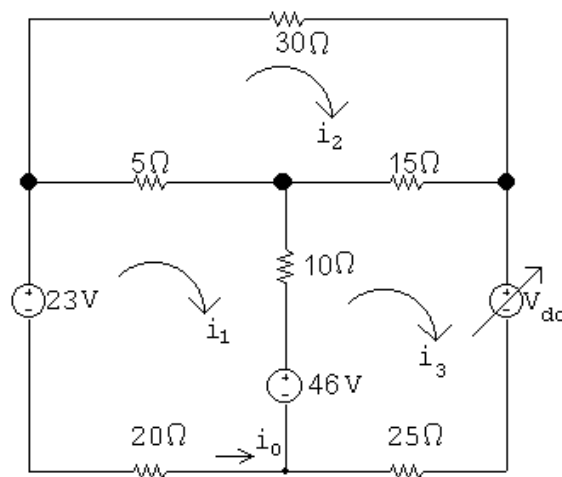

Write the mesh current equations. Note that if $i_o = 0$, then $i_1 = 0$:

$$-23 + 5(-i_2) + 10(-i_3) + 46 = 0$$

$$30i_2 + 15(i_2 - i_3) + 5i_2 = 0$$

$$V_{dc} + 25i_3 - 46 + 10i_3 + 15(i_3 - i_2) = 0$$

Place the equations in standard form:

$$i_2(-5) + i_3(-10) + V_{dc}(0) = -23$$

$$i_2(30 + 15 + 5) + i_3(-15) + V_{dc}(0) = 0$$

$$i_2(-15) + i_3(25 + 10 + 15) + V_{dc}(1) = 46$$

Solving, $i_2 = 0.6 \text{ A}$; $i_3 = 2 \text{ A}$; $V_{dc} = -45 \text{ V}$

Thus, the value of V_{dc} required to make $i_o = 0$ is -45 V .

[c] Calculate the power:

$$p_{23\text{V}} = -(23)(0) = 0 \text{ W}$$

$$p_{46\text{V}} = -(46)(2) = -92 \text{ W}$$

$$p_{V_{dc}} = (-45)(2) = -90 \text{ W}$$

$$p_{30\Omega} = (30)(0.6)^2 = 10.8 \text{ W}$$

$$p_{5\Omega} = (5)(0.6)^2 = 1.8 \text{ W}$$

$$p_{15\Omega} = (15)(2 - 0.6)^2 = 29.4 \text{ W}$$

$$p_{10\Omega} = (10)(2)^2 = 40 \text{ W}$$

$$p_{20\Omega} = (20)(0)^2 = 0 \text{ W}$$

$$p_{25\Omega} = (25)(2)^2 = 100 \text{ W}$$

$$\sum p_{\text{dev}} = 92 + 90 = 182 \text{ W}$$

$$\sum p_{\text{dis}} = 10.8 + 1.8 + 29.4 + 40 + 0 + 100 = 182 \text{ W (checks)}$$

P 4.59 [a]

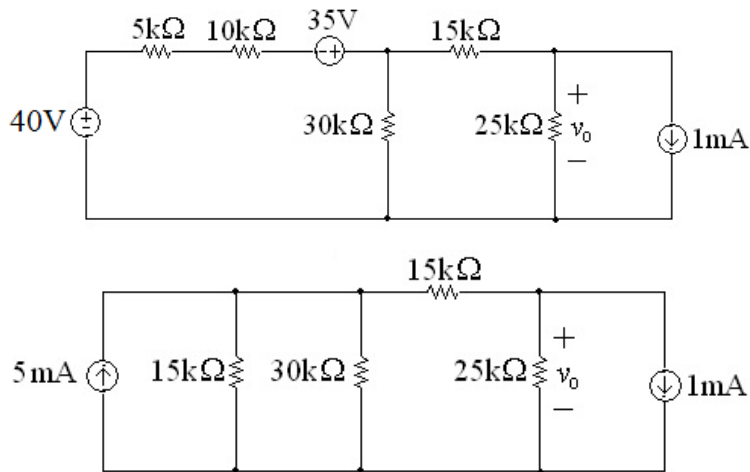

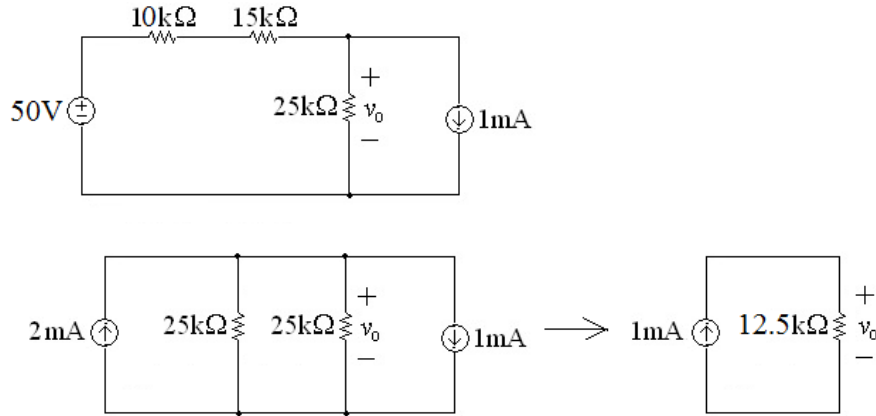

$$v_o = (12,500)(0.001) = 12.5 \text{ V}$$

[b]

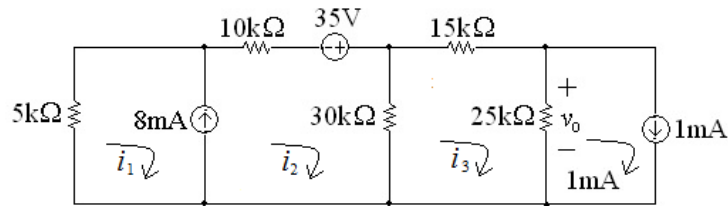

$$5000i_1 + 40,000i_2 - 30,000i_3 = 35$$

$$i_2 - i_1 = 0.008$$

$$-30,000i_2 + 70,000i_3 = 25$$

Solving,

$$i_1 = -5.33 \text{ mA}; \quad i_2 = 2.667 \text{ mA}; \quad i_3 = 1.5 \text{ mA}$$

$$v_o = (25,000)(i_3 - 0.001) = (25,000)(0.0005) = 12.5 \text{ V}$$

P 4.60 [a]

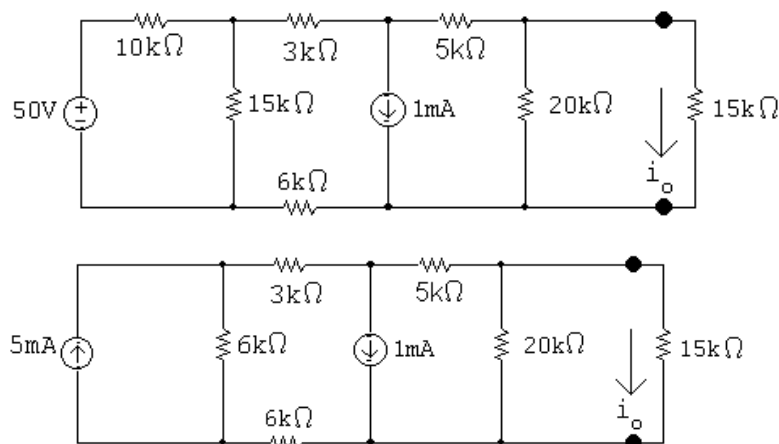

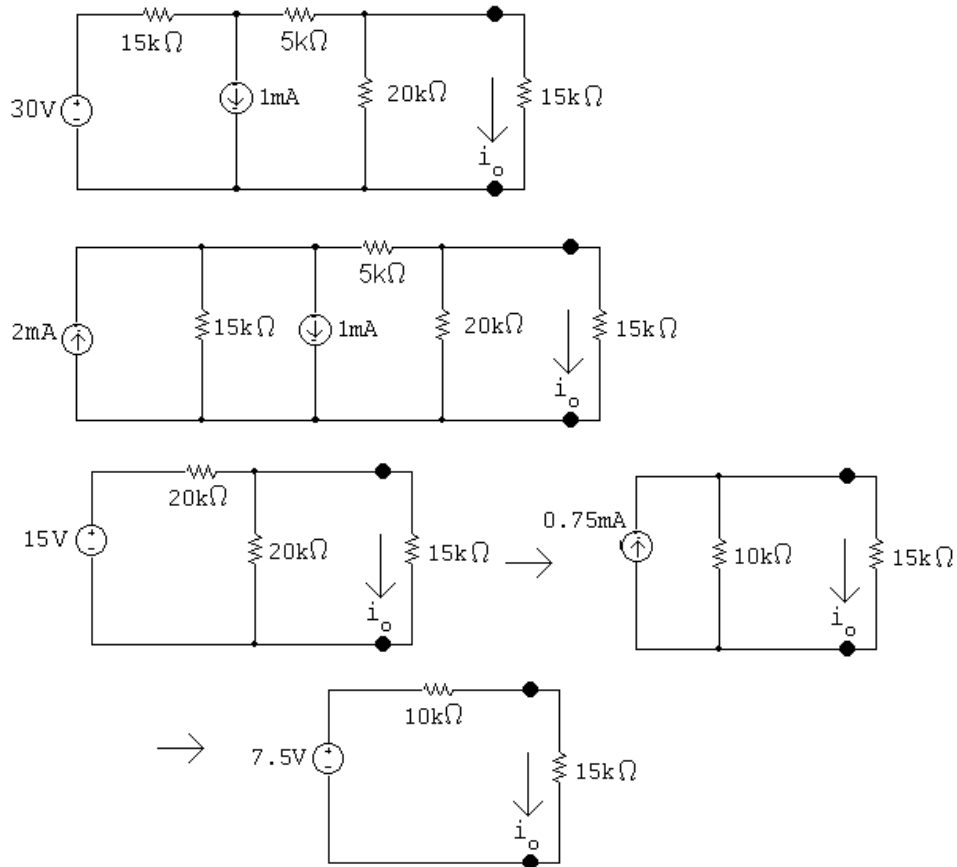

$$i_o = \frac{7.5}{25,000} = 0.3 \text{ mA}$$

[b]

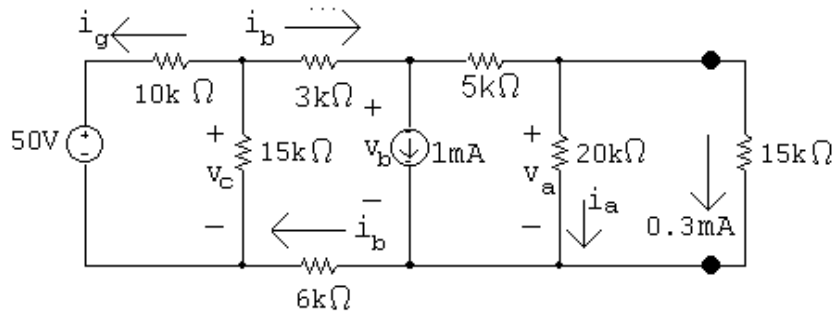

$$v_a = (15,000)(0.0003) = 4.5 \text{ V}$$

$$i_a = \frac{v_a}{20,000} = 225 \mu\text{A}$$

$$i_b = 1 + 0.225 + 0.3 = 1.525 \text{ mA}$$

$$v_b = 5000(0.525 \times 10^{-3}) + 4.5 = 7.125 \text{ V}$$

$$v_c = 3000(1.525 \times 10^{-3}) + 7.125 + 6000(1.525 \times 10^{-3}) = 20.85 \text{ V}$$

$$i_g = \frac{20.85 - 50}{10,000} = -2.915 \text{ mA}$$

$$p_{50V} = (50)(-2.915 \times 10^{-3}) = -145.75 \text{ mW}$$

Check:

$$p_{1mA} = (7.125)(10^{-3}) = 7.125 \text{ mW}$$

$$\sum P_{\text{dev}} = 145.75 \text{ mW}$$

$$\begin{aligned} \sum P_{\text{dis}} &= (10,000)(2.915 \times 10^{-3})^2 + (20.85)^2/15,000 + (9000)(1.525 \times 10^{-3})^2 \\ &\quad + (5000)(0.525 \times 10^{-3})^2 + (20,000)(0.225 \times 10^{-3})^2 \\ &\quad + (15,000)(0.3 \times 10^{-3})^2 + 7.125 \times 10^{-3} \\ &= 145.75 \text{ mW} \end{aligned}$$

P 4.61 [a] Apply source transformations to both current sources to get

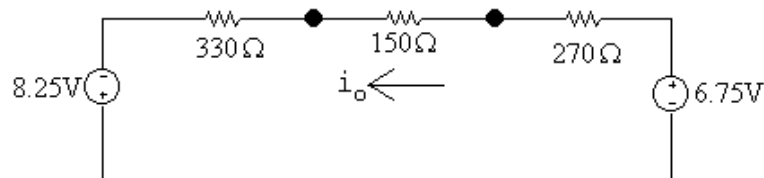

$$i_o = \frac{(6.75 + 8.25)}{330 + 150 + 270} = 20 \text{ mA}$$

[b]

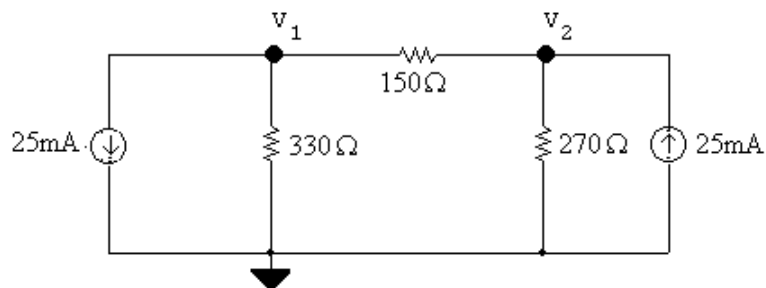

The node voltage equations:

$$0.025 + \frac{v_1}{330} + \frac{v_1 - v_2}{150} = 0$$

$$\frac{v_2}{270} + \frac{v_2 - v_1}{150} - 0.025 = 0$$

Place these equations in standard form:

$$v_1 \left(\frac{1}{330} + \frac{1}{150} \right) + v_2 \left(-\frac{1}{150} \right) = -0.025$$

$$v_1 \left(-\frac{1}{150} \right) + v_2 \left(\frac{1}{270} + \frac{1}{150} \right) = 0.025$$

$$\text{Solving, } v_1 = -1.65 \text{ V; } v_2 = 1.35 \text{ V}$$

$$\therefore i_o = \frac{v_2 - v_1}{150} = 20 \text{ mA}$$

P 4.62 [a] Applying a source transformation to each current source yields

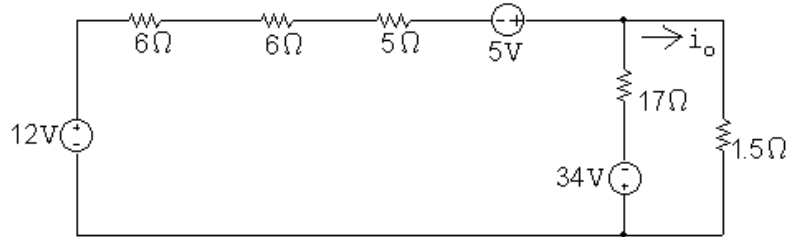

Now combine the 12 V and 5 V sources into a single voltage source and the 6 Ω, 6 Ω and 5 Ω resistors into a single resistor to get

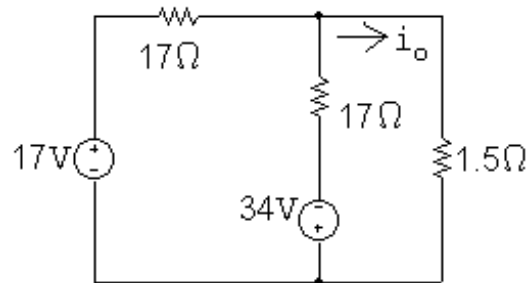

Now use a source transformation on each voltage source, thus

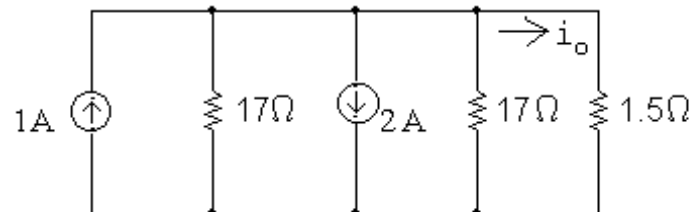

which can be reduced to

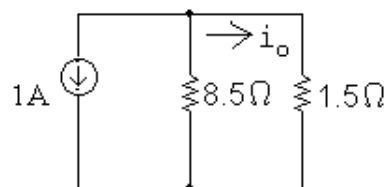

$$\therefore i_o = -\frac{8.5}{10}(1) = -0.85 \text{ A}$$

[b]

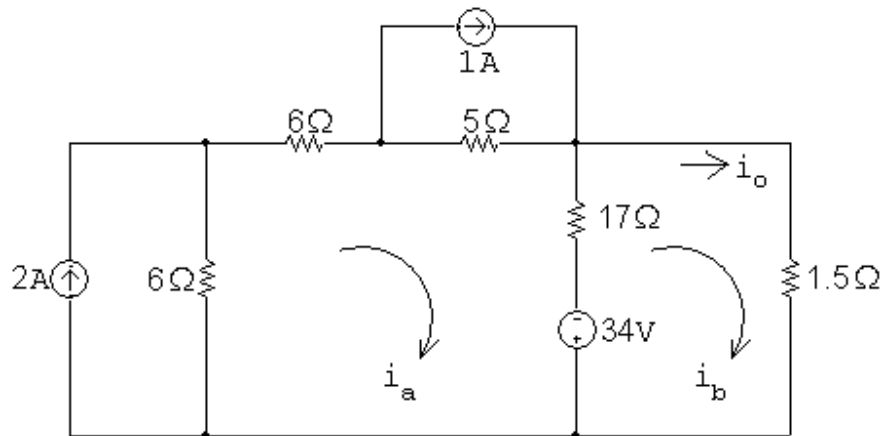

$$34i_a - 17i_b = 12 + 5 + 34 = 51$$

$$-17i_a + 18.5i_b = -34$$

Solving, $i_b = -0.85 \text{ A} = i_o$

P 4.63 [a] First remove the 16Ω and 260Ω resistors:

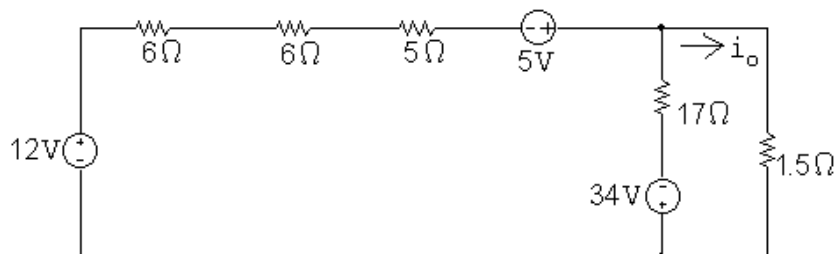

Next use a source transformation to convert the 1 A current source and 40Ω resistor:

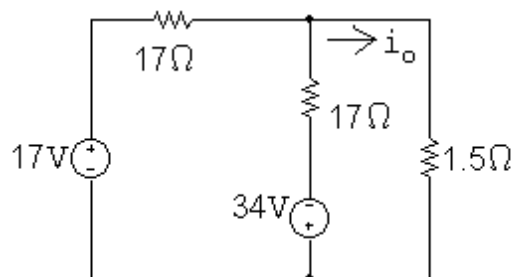

which simplifies to

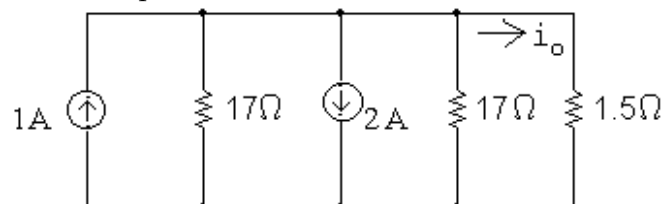

$$\therefore v_o = \frac{250}{300}(480) = 400 \text{ V}$$

[b] Return to the original circuit with $v_o = 400$ V:

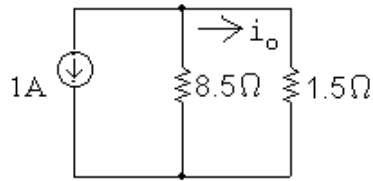

$$i_g = \frac{520}{260} + 1.6 = 3.6 \text{ A}$$

$$p_{520\text{V}} = -(520)(3.6) = -1872 \text{ W}$$

Therefore, the 520 V source is developing 1872 W.

[c] $v_1 = -520 + 1.6(4 + 250 + 6) = -104$ V

$$v_g = v_1 - 1(16) = -104 - 16 = -120 \text{ V}$$

$$p_{1\text{A}} = (1)(-120) = -120 \text{ W}$$

Therefore the 1 A source is developing 120 W.

[d] $\sum p_{\text{dev}} = 1872 + 120 = 1992$ W

$$\sum p_{\text{diss}} = (1)^2(16) + \frac{(104)^2}{40} + \frac{(520)^2}{260} + (1.6)^2(260) = 1992 \text{ W}$$

$$\therefore \sum p_{\text{diss}} = \sum p_{\text{dev}}$$

P 4.64 $v_{\text{Th}} = \frac{30}{40}(80) = 60$ V

$$R_{\text{Th}} = 2.5 + \frac{(30)(10)}{40} = 10 \Omega$$

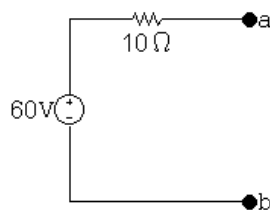

P 4.65 Find the open-circuit voltage:

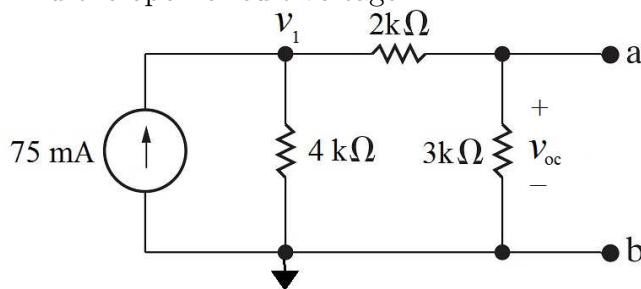

$$-0.075 + \frac{v_1}{4000} + \frac{v_1}{5000} = 0$$

$$v_1 = 166.67 \text{ V}; \quad \text{so} \quad v_{oc} = \frac{3000}{5000}v_1 = 100 \text{ V}$$

Find the short-circuit current:

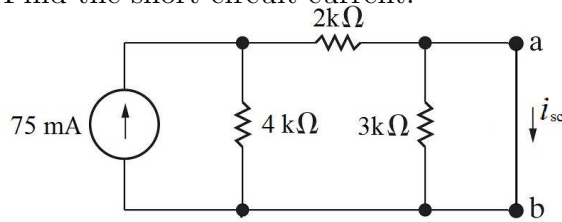

$$i_{sc} = \frac{4000 \parallel 2000}{2000} (0.075) = 50 \text{ mA}$$

Thus,

$$I_N = i_{sc} = 50 \text{ mA}; \quad R_N = \frac{v_{oc}}{i_{sc}} = \frac{100}{0.05} = 2 \text{ k}\Omega$$

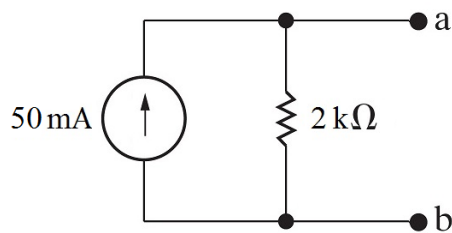

P 4.66

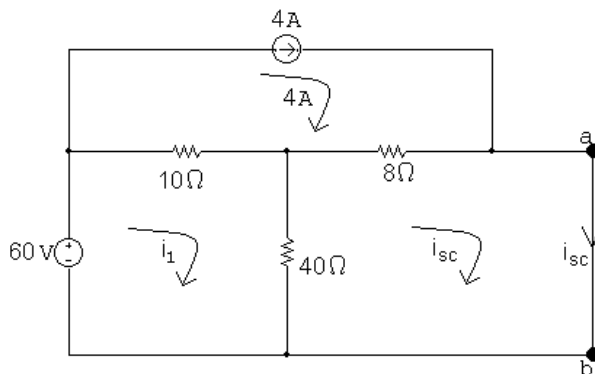

$$50i_1 - 40i_{sc} = 60 + 40$$

$$-40i_1 + 48i_{sc} = 32$$

Solving, $i_{sc} = 7 \text{ A}$

$$R_{Th} = 8 + \frac{(10)(40)}{50} = 16 \Omega$$

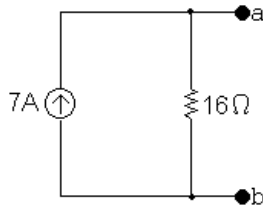

P 4.67 After making a source transformation the circuit becomes

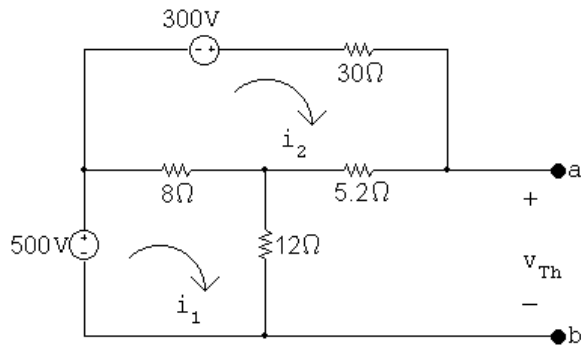

$$500 = 20i_1 - 8i_2$$

$$300 = -8i_1 + 43.2i_2$$

$$\therefore i_1 = 30 \text{ A and } i_2 = 12.5 \text{ A}$$

$$v_{Th} = 12i_1 + 5.2i_2 = 425 \text{ V}$$

$$R_{Th} = (8 \parallel (12 + 5.2)) \parallel 30 = 7.5 \Omega$$

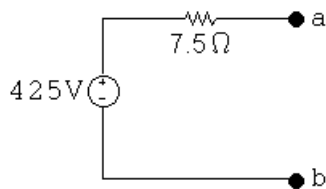

P 4.68 First we make the observation that the 10 mA current source and the 10 kΩ resistor will have no influence on the behavior of the circuit with respect to the terminals a,b. This follows because they are in parallel with an ideal voltage source. Hence our circuit can be simplified to

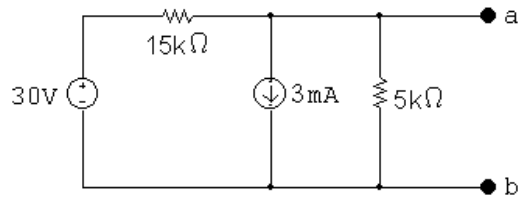

or

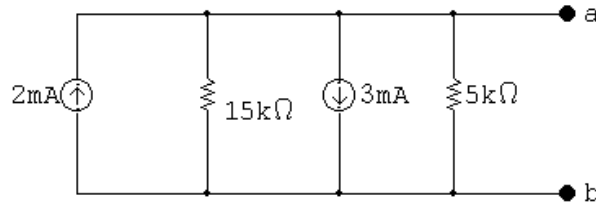

Therefore the Norton equivalent is

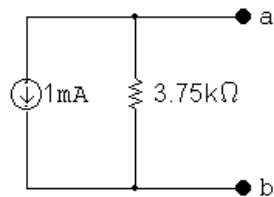

P 4.69

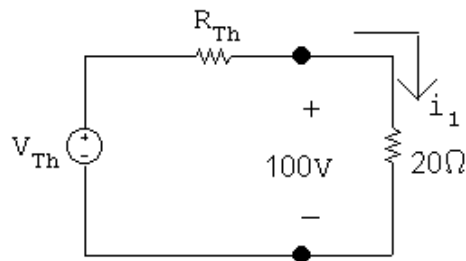

$$i_1 = 100/20 = 5 \text{ A}$$

$$100 = v_{Th} - 5R_{Th}, \quad v_{Th} = 100 + 5R_{Th}$$

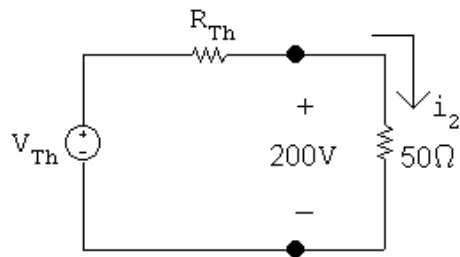

$$i_2 = 200/50 = 4 \text{ A}$$

$$200 = v_{Th} - 4R_{Th}, \quad v_{Th} = 200 + 4R_{Th}$$

$$\therefore 100 + 5R_{Th} = 200 + 4R_{Th} \quad \text{so} \quad R_{Th} = 100\Omega$$

$$v_{Th} = 100 + 500 = 600\text{ V}$$

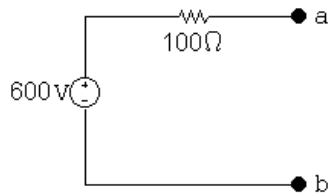

P 4.70

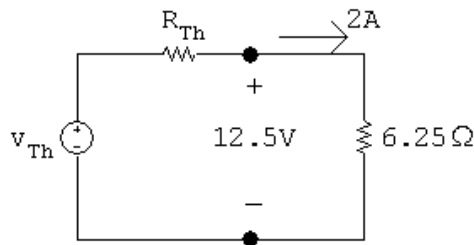

$$12.5 = v_{Th} - 2R_{Th}$$

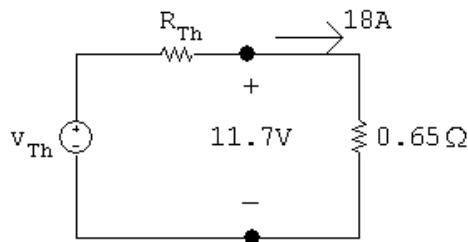

$$11.7 = v_{Th} - 18R_{Th}$$

Solving the above equations for V_{Th} and R_{Th} yields

$$v_{Th} = 12.6\text{ V}, \quad R_{Th} = 50\text{ m}\Omega$$

$$\therefore I_N = 252\text{ A}, \quad R_N = 50\text{ m}\Omega$$

P 4.71 First, find the Thévenin equivalent with respect to R_o .

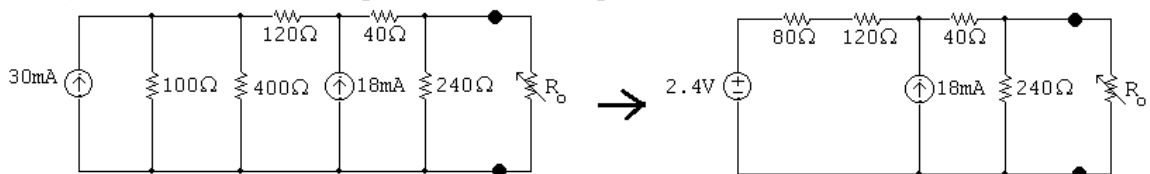

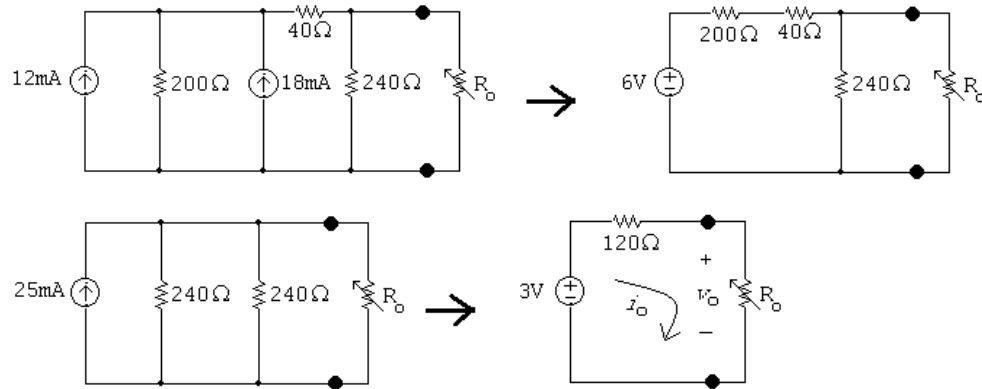

$R_o(\Omega)$	$i_o(\text{mA})$	$v_o(\text{V})$
100	13.64	1.364
120	12.5	1.5
150	11.11	1.667
180	10	1.8

P 4.72 [a] First, find the Thévenin equivalent with respect to a,b using a succession of source transformations.

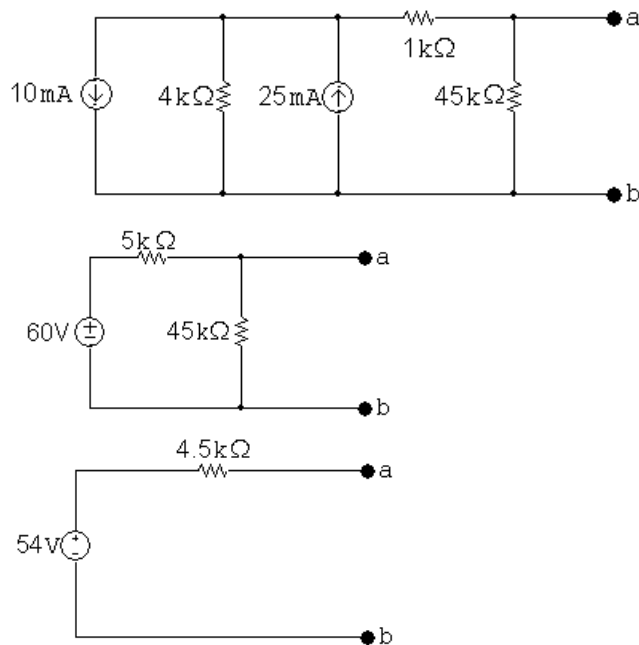

$$\therefore v_{Th} = 54 \text{ V} \quad R_{Th} = 4.5 \text{ k}\Omega$$

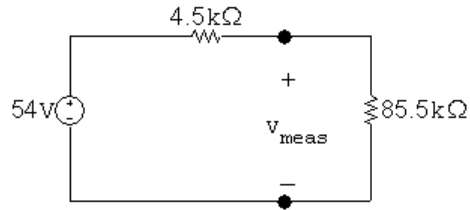

$$v_{\text{meas}} = \frac{54}{90}(85.5) = 51.3 \text{ V}$$

$$\text{[b] } \% \text{error} = \left(\frac{51.3 - 54}{54} \right) \times 100 = -5\%$$

P 4.73

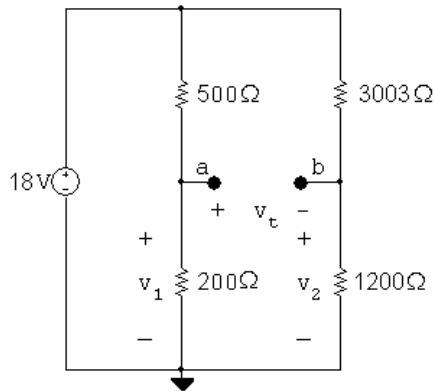

$$v_1 = \frac{200}{700}(18) = 5.143 \text{ V}$$

$$v_2 = \frac{1200}{4203}(18) = 5.139 \text{ V}$$

$$v_{\text{Th}} = v_1 - v_2 = 5.143 - 5.139 = 3.67 \text{ mV}$$

$$R_{\text{Th}} = \frac{(500)(200)}{700} + \frac{(3003)(1200)}{4203} = 1000.24 \Omega$$

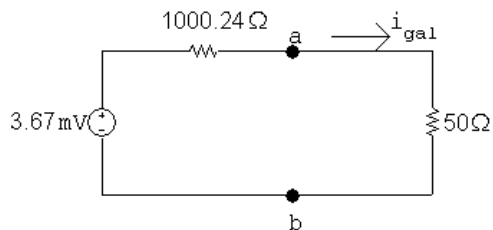

$$i_{\text{gal}} = \frac{3.67 \times 10^{-3}}{1050.24} = 3.5 \mu\text{A}$$

P 4.74

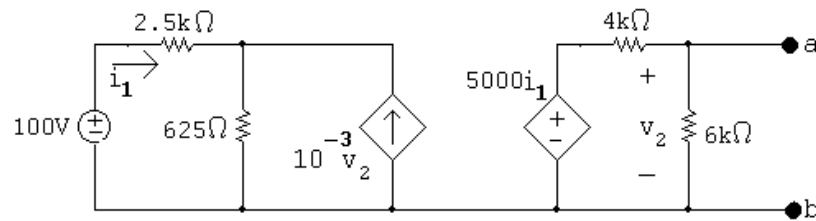

OPEN CIRCUIT

$$100 = 2500i_1 + 625(i_1 + 10^{-3}v_2)$$

$$v_2 = \frac{6000}{10,000}(5000i_1)$$

Solving,

$$i_1 = 0.02 \text{ A}; \quad v_2 = v_{oc} = 60 \text{ V}$$

SHORT CIRCUIT

$$v_2 = 0; \quad i_{sc} = \frac{5000}{4000}i_1$$

$$i_1 = \frac{100}{2500 + 625} = 0.032 \text{ A}$$

Thus,

$$i_{sc} = \frac{5}{4}i_1 = 0.04 \text{ A}$$

$$R_{Th} = \frac{60}{0.04} = 1.5 \text{ k}\Omega$$

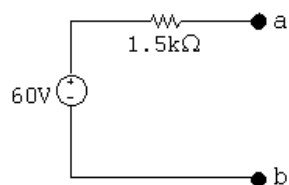

P 4.75

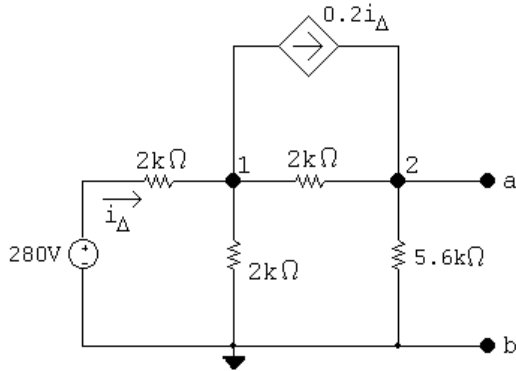

The node voltage equations and dependant source equation are:

$$\frac{v_1 - 280}{2000} + \frac{v_1}{2000} + \frac{v_1 - v_2}{2000} + 0.2i_{\Delta} = 0$$

$$\frac{v_2 - v_1}{2000} + \frac{v_2}{5600} - 0.2i_{\Delta} = 0$$

$$i_{\Delta} = \frac{280 - v_1}{2000}$$

In standard form:

$$v_1 \left(\frac{1}{2000} + \frac{1}{2000} + \frac{1}{2000} \right) + v_2 \left(-\frac{1}{2000} \right) + i_{\Delta}(0.2) = \frac{280}{2000}$$

$$v_1 \left(-\frac{1}{2000} \right) + v_2 \left(\frac{1}{2000} + \frac{1}{5600} \right) + i_{\Delta}(-0.2) = 0$$

$$v_1 \left(\frac{1}{2000} \right) + v_2(0) + i_{\Delta}(1) = \frac{280}{2000}$$

Solving, $v_1 = 120 \text{ V}$; $v_2 = 112 \text{ V}$; $i_{\Delta} = 0.08 \text{ A}$

$V_{Th} = v_2 = 112 \text{ V}$

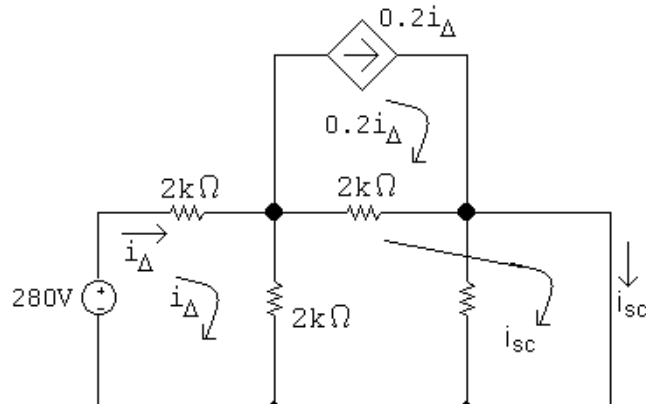

The mesh current equations are:

$$\begin{aligned}
 -280 + 2000i_{\Delta} + 2000(i_{\Delta} - i_{sc}) &= 0 \\
 2000(i_{sc} - 0.2i_{\Delta}) + 2000(i_{sc} - i_{\Delta}) &= 0
 \end{aligned}$$

Put these equations in standard form:

$$\begin{aligned}
 i_{\Delta}(4000) + i_{sc}(-2000) &= 280 \\
 i_{\Delta}(-2400) + i_{sc}(4000) &= 0
 \end{aligned}$$

Solving, $i_{\Delta} = 0.1 \text{ A}$; $i_{sc} = 0.06 \text{ A}$

$$R_{Th} = \frac{112}{0.06} = 1866.67 \Omega$$

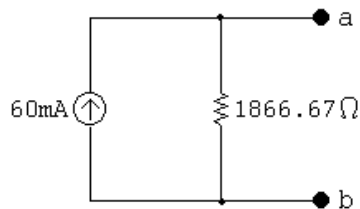

P 4.76 [a] Find the Thévenin equivalent with respect to the terminals of the ammeter. This is most easily done by first finding the Thévenin with respect to the terminals of the 4.8Ω resistor.

Thévenin voltage: note i_{ϕ} is zero.

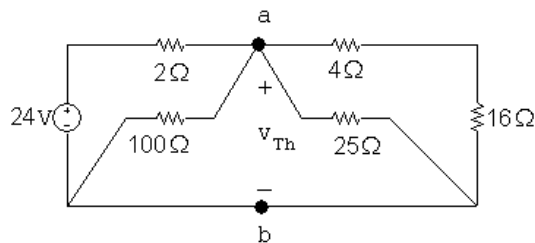

$$\frac{v_{Th}}{100} + \frac{v_{Th}}{25} + \frac{v_{Th}}{20} + \frac{v_{Th} - 16}{2} = 0$$

Solving, $v_{Th} = 20 \text{ V}$.

Short-circuit current:

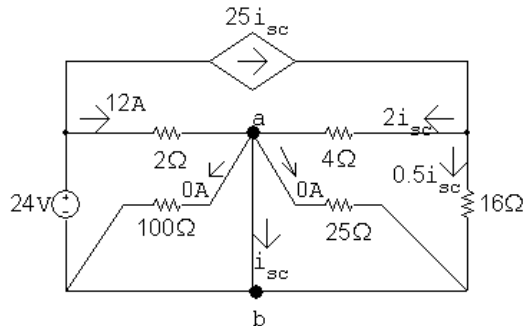

$$i_{sc} = 12 + 2i_{sc}, \quad \therefore i_{sc} = -12 \text{ A}$$

$$R_{Th} = \frac{20}{-12} = -(5/3) \Omega$$

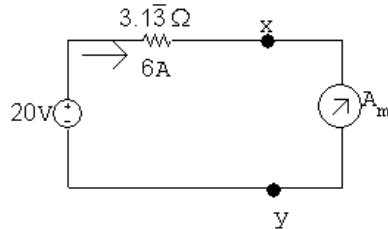
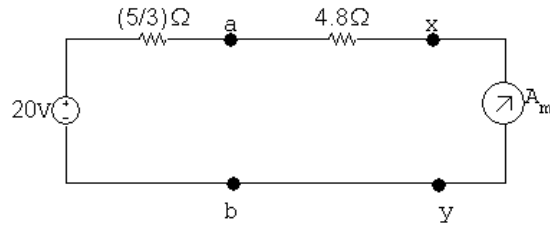

$$R_{\text{total}} = \frac{20}{6} = 3.33 \Omega$$

$$R_{\text{meter}} = 3.33 - 3.13 = 0.2 \Omega$$

[b] Actual current:

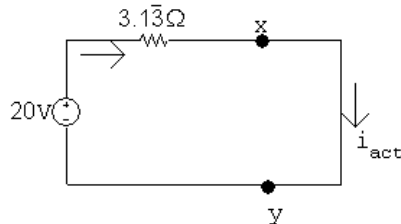

$$i_{\text{actual}} = \frac{20}{3.13} = 6.38 \text{ A}$$

$$\% \text{ error} = \frac{6 - 6.38}{6.38} \times 100 = -6\%$$

P 4.77 [a] Replace the voltage source with a short circuit and find the equivalent resistance from the terminals a,b:

$$R_{\text{Th}} = 10 \parallel 30 + 2.5 = 10 \Omega$$

[b] Replace the current source with an open circuit and the voltage source with a short circuit. Find the equivalent resistance from the terminals a,b:

$$R_{\text{Th}} = 10 \parallel 40 + 8 = 16 \Omega$$

P 4.78 [a] Open circuit:

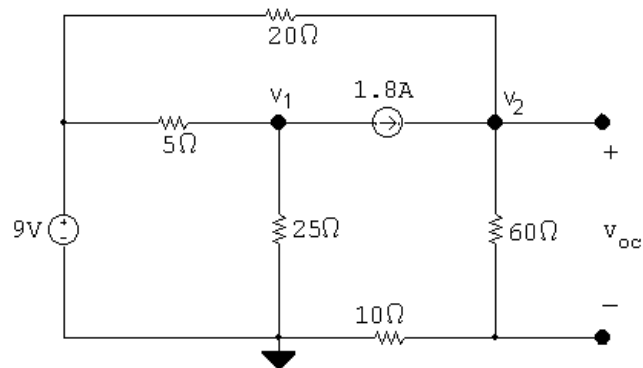

$$\frac{v_2 - 9}{20} + \frac{v_2}{70} - 1.8 = 0$$

$$v_2 = 35 \text{ V}$$

$$v_{\text{Th}} = \frac{60}{70}v_2 = 30 \text{ V}$$

Short circuit:

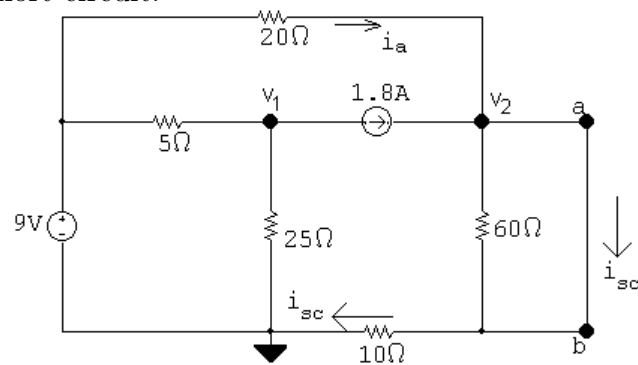

$$\frac{v_2 - 9}{20} + \frac{v_2}{10} - 1.8 = 0$$

$$\therefore v_2 = 15 \text{ V}$$

$$i_a = \frac{9 - 15}{20} = -0.3 \text{ A}$$

$$i_{\text{sc}} = 1.8 - 0.3 = 1.5 \text{ A}$$

$$R_{\text{Th}} = \frac{30}{1.5} = 20 \Omega$$

[b]

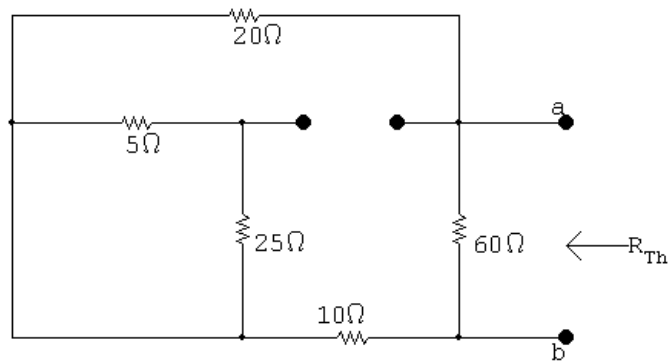

$$R_{Th} = (20 + 10 \parallel 60) = 20 \Omega \text{ (CHECKS)}$$

P 4.79 $V_{Th} = 0$, since circuit contains no independent sources.

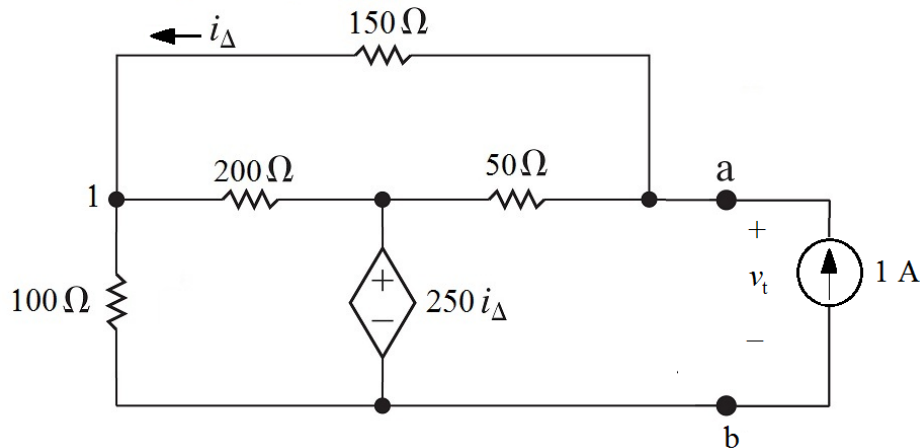

$$\frac{v_1}{100} + \frac{v_1 - 250i_\Delta}{200} + \frac{v_1 - v_t}{150} = 0$$

$$\frac{v_t - v_1}{150} + \frac{v_t - 250i_\Delta}{50} - 1 = 0$$

$$i_\Delta = \frac{v_t - v_1}{150}$$

In standard form:

$$v_1 \left(\frac{1}{100} + \frac{1}{200} + \frac{1}{150} \right) + v_t \left(-\frac{1}{150} \right) + i_\Delta \left(-\frac{250}{200} \right) = 0$$

$$v_1 \left(-\frac{1}{150} \right) + v_t \left(\frac{1}{150} + \frac{1}{50} \right) + i_\Delta \left(-\frac{250}{50} \right) = 1$$

$$v_1 \left(-\frac{1}{150} \right) + v_t \left(\frac{1}{150} \right) + i_\Delta (-1) = 0$$

Solving,

$$v_1 = 75 \text{ V}; \quad v_t = 150 \text{ V}; \quad i_{\Delta} = 0.5 \text{ A}$$

$$\therefore R_{\text{Th}} = \frac{v_t}{1 \text{ A}} = 150 \Omega$$

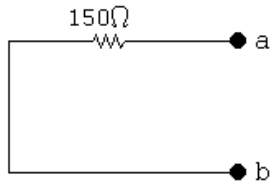

P 4.80 Since there is no independent source, $V_{\text{Th}} = 0$. Now apply a test source at the terminals a,b to find the Thévenin equivalent resistance:

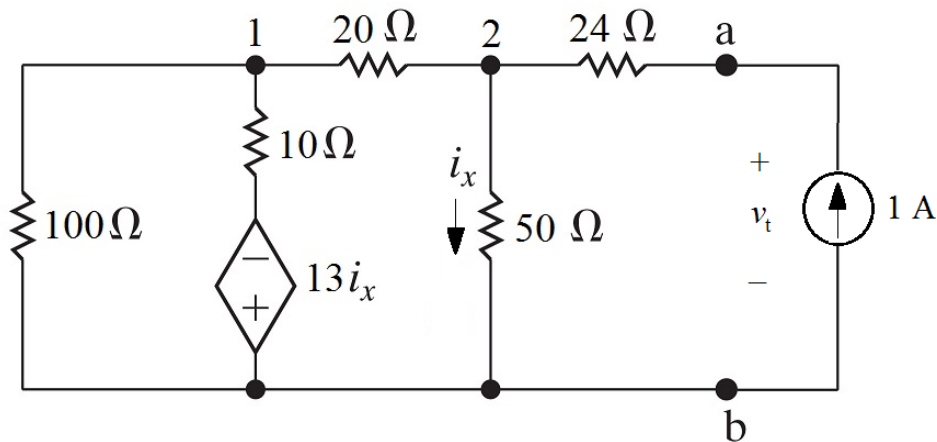

$$\frac{v_1}{100} + \frac{v_1 + 13i_x}{10} + \frac{v_1 - v_2}{20} = 0$$

$$\frac{v_2 - v_1}{20} + \frac{v_2}{50} - 1 = 0$$

$$i_x = \frac{v_2}{50}$$

Solving,

$$v_1 = 2.4 \text{ V}; \quad v_2 = 16 \text{ V}; \quad i_x = 0.32 \text{ A}$$

$$v_t - 24(1) = v_2; \quad \text{so} \quad v_t = 16 + 24 = 40 \text{ V}$$

$$R_{\text{Th}} = \frac{v_t}{1 \text{ A}} = 40 \Omega$$

The Thévenin equivalent is simply a 40Ω resistor.

P 4.81 $V_{Th} = 0$ since there are no independent sources in the circuit. Thus we need only find R_{Th} .

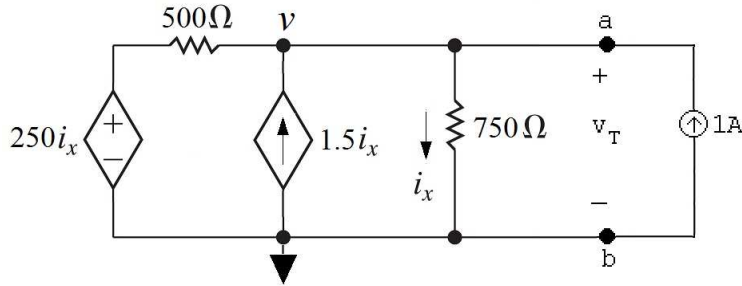

$$\frac{v - 250i_x}{500} - 1.5i_x + \frac{v}{750} - 1 = 0$$

$$i_x = \frac{v}{750}$$

Solving,

$$v = 1500 \text{ V}; \quad i_x = 2 \text{ A}$$

$$R_{Th} = \frac{v}{1 \text{ A}} = 1500 = 1.5 \text{ k}\Omega$$

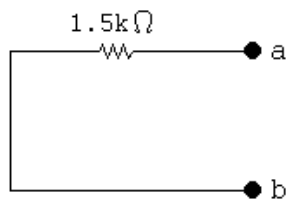

P 4.82 [a]

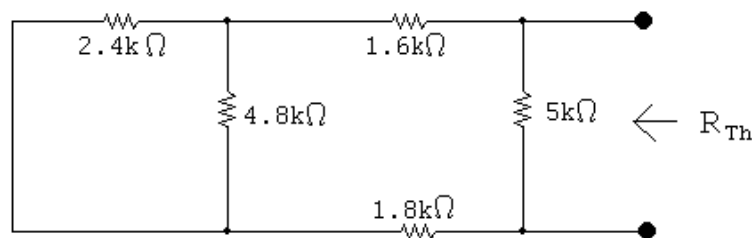

$$R_{Th} = 5000 \parallel (1600 + 2400 \parallel 4800 + 1800) = 2.5 \text{ k}\Omega$$

$$R_o = R_{Th} = 2.5 \text{ k}\Omega$$

[b]

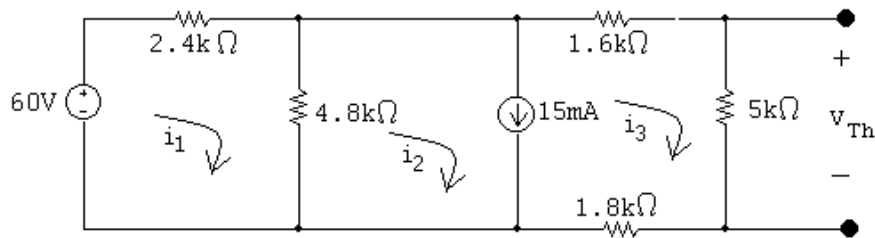

$$7200i_1 - 4800i_2 = 60$$

$$-4800i_1 + 4800i_2 + 8400i_3 = 0$$

$$i_2 - i_3 = 0.015$$

Solving,

$$i_1 = 19.4 \text{ mA}; \quad i_2 = 16.6 \text{ mA}; \quad i_3 = 1.6 \text{ mA}$$

$$v_{oc} = 5000i_3 = 8 \text{ V}$$

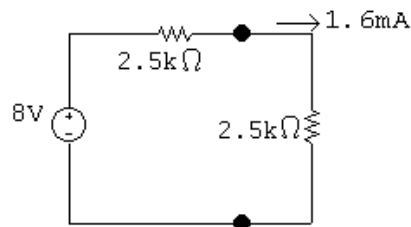

$$p_{\max} = (1.6 \times 10^{-3})^2(2500) = 6.4 \text{ mW}$$

[c] The resistor closest to $2.5 \text{ k}\Omega$ from Appendix H has a value of $2.7 \text{ k}\Omega$. Use voltage division to find the voltage drop across this load resistor, and use the voltage to find the power delivered to it:

$$v_{2.7\text{k}} = \frac{2700}{2700 + 2500}(8) = 4.154 \text{ V}$$

$$p_{2.7\text{k}} = \frac{(4.154)^2}{2700} = 6.391 \text{ mW}$$

The percent error between the maximum power and the power delivered to the best resistor from Appendix H is

$$\% \text{ error} = \left(\frac{6.391}{6.4} - 1 \right) (100) = -0.1\%$$

P 4.83 Write KVL equations for the left mesh and the supermesh, place them in standard form, and solve:

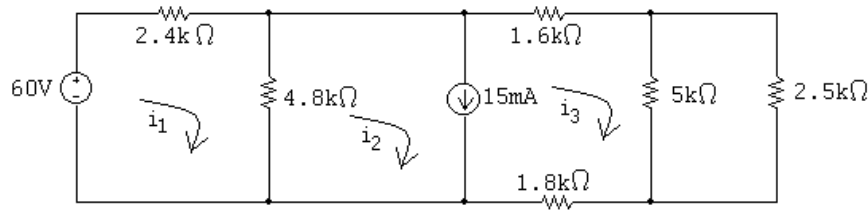

$$\text{At } i_1: \quad -60 + 2400i_1 + 4800(i_1 - i_2) = 0$$

$$\text{Supermesh:} \quad 4800(i_2 - i_1) + 1600i_3 + (5000 \parallel 2500)i_3 + 1800i_3 = 0$$

$$\text{Constraint:} \quad i_2 - i_3 = 0.015 = 0$$

Standard form:

$$i_1(7200) + i_2(-4800) + i_3(0) = 60$$

$$i_1(-4800) + i_2(4800) + i_3(5066.67) = 0$$

$$i_1(0) + i_2(1) + i_3(-1) = 0.015$$

Calculator solution:

$$i_1 = 19.933 \text{ mA}; \quad i_2 = 17.4 \text{ mA}; \quad i_3 = 2.4 \text{ mA}$$

Calculate voltage across the current source:

$$v_{15\text{mA}} = 4800(i_1 - i_2) = 12.16 \text{ V}$$

Calculate power delivered by the sources:

$$p_{15\text{mA}} = (0.015)(12.16) = 182.4 \text{ mW (abs)}$$

$$p_{60\text{V}} = -60i_1 = -60(0.019933) = -1.196 \text{ W (del)}$$

$$p_{\text{delivered}} = 1.196 \text{ W}$$

Calculate power absorbed by the 2.5kΩ resistor and the percentage power:

$$i_{2.5\text{k}} = \frac{5000 \parallel 2500}{2500} i_3 = 1.6 \text{ mA}$$

$$p_{2.5\text{k}} = (0.0016)^2(2500) = 6.4 \text{ mW}$$

$$\% \text{ delivered to } R_o: \quad \frac{0.0064}{1.196}(100) = 0.535\%$$

P 4.84 [a] From the solution to Problem 4.71 we have

$R_o(\Omega)$	$p_o(\text{mW})$
100	18.595
120	18.75
150	18.52
180	18

The $120\ \Omega$ resistor dissipates the most power, because its value is equal to the Thévenin equivalent resistance of the circuit.

[b]

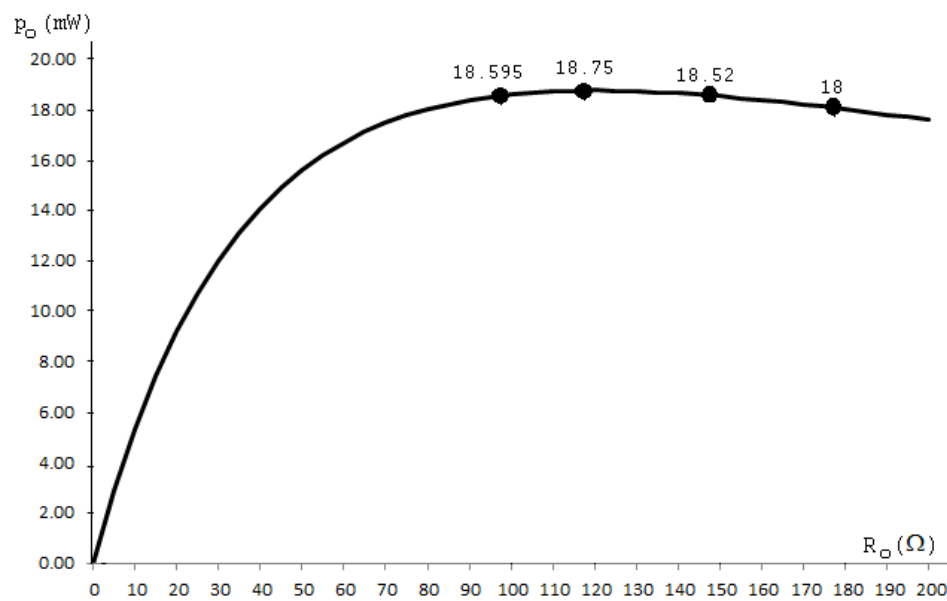

[c] $R_o = 120\ \Omega$, $p_o = 18.75\ \text{mW}$, which is the maximum power that can be delivered to a load resistor.

P 4.85 [a] Since $0 \leq R_o \leq \infty$ maximum power will be delivered to the $6\ \Omega$ resistor when $R_o = 0$.

[b]
$$P = \frac{30^2}{6} = 150\ \text{W}$$

P 4.86 [a] From the solution of Problem 4.75 we have $R_{\text{Th}} = 1866.67\ \Omega$ and $V_{\text{Th}} = 112\ \text{V}$. Therefore

$$R_o = R_{\text{Th}} = 1866.67\ \Omega$$

[b]
$$p = \frac{(56)^2}{1866.67} = 1.68\ \text{W}$$

[c]

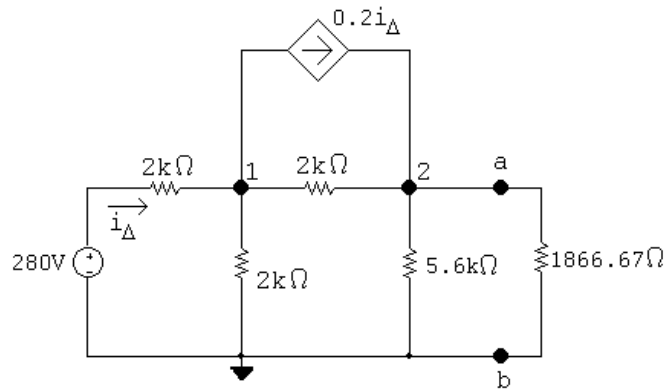

The node voltage equations are:

$$\frac{v_1 - 280}{2000} + \frac{v_1}{2000} + \frac{v_1 - v_2}{2000} + 0.2i_{\Delta} = 0$$

$$\frac{v_2 - v_1}{2000} + \frac{v_2}{5600} + \frac{v_2}{1866.67} - 0.2i_{\Delta} = 0$$

The dependent source constraint equation is:

$$i_{\Delta} = \frac{280 - v_1}{2000}$$

Place these equations in standard form:

$$v_1 \left(\frac{1}{2000} + \frac{1}{2000} + \frac{1}{2000} \right) + v_2 \left(-\frac{1}{2000} \right) + i_{\Delta}(0.2) = \frac{280}{2000}$$

$$v_1 \left(-\frac{1}{2000} \right) + v_2 \left(\frac{1}{2000} + \frac{1}{5600} + \frac{1}{1866.67} \right) + i_{\Delta}(-0.2) = 0$$

$$v_1(1) + v_2(0) + i_{\Delta}(2000) = 280$$

$$\text{Solving, } v_1 = 100 \text{ V; } v_2 = 56 \text{ V; } i_{\Delta} = 90 \text{ mA}$$

Calculate the power:

$$p_{280\text{V}} = -(280)(0.09) = -25.2 \text{ W}$$

$$p_{\text{dep source}} = (v_1 - v_2)(0.2i_{\Delta}) = 0.792 \text{ W}$$

$$\sum p_{\text{dev}} = 25.2 \text{ W}$$

$$\% \text{ delivered} = \frac{1.68}{25.2} \times 100 = 6.67\%$$

[d] The 1.8 kΩ resistor in Appendix H is closest to the Thévenin equivalent resistance.

[e] Substitute the 1.8 kΩ resistor into the original circuit and calculate the power developed by the sources in this circuit:

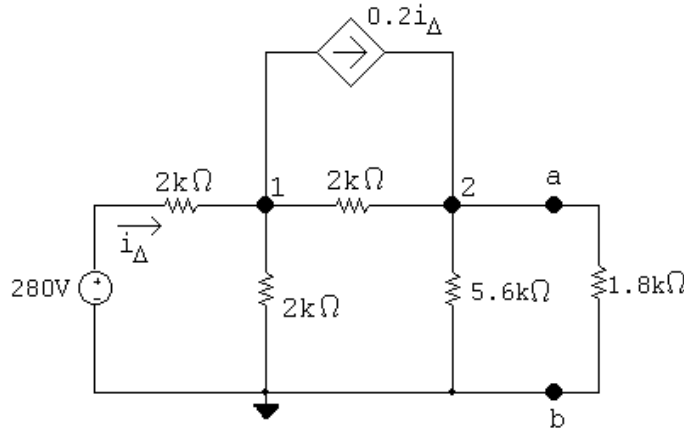

The node voltage equations are:

$$\frac{v_1 - 280}{2000} + \frac{v_1}{2000} + \frac{v_1 - v_2}{2000} + 0.2i_\Delta = 0$$

$$\frac{v_2 - v_1}{2000} + \frac{v_2}{5600} + \frac{v_2}{1800} - 0.2i_\Delta = 0$$

The dependent source constraint equation is:

$$i_\Delta = \frac{280 - v_1}{2000}$$

Place these equations in standard form:

$$v_1 \left(\frac{1}{2000} + \frac{1}{2000} + \frac{1}{2000} \right) + v_2 \left(-\frac{1}{2000} \right) + i_\Delta(0.2) = \frac{280}{2000}$$

$$v_1 \left(-\frac{1}{2000} \right) + v_2 \left(\frac{1}{2000} + \frac{1}{5600} + \frac{1}{1800} \right) + i_\Delta(-0.2) = 0$$

$$v_1(1) + v_2(0) + i_\Delta(2000) = 280$$

Solving, $v_1 = 99.64 \text{ V}$; $v_2 = 54.98 \text{ V}$; $i_\Delta = 90.18 \text{ mA}$

Calculate the power:

$$p_{280V} = -(280)(0.09018) = -25.25 \text{ W}$$

$$\sum p_{\text{dev}} = 25.25 \text{ mW}$$

$$p_L = (54.98)^2 / 1800 = 1.68 \text{ W} \quad \% \text{ delivered} = \frac{1.68}{25.25} \times 100 = 6.65\%$$

P 4.87 [a] Open circuit voltage

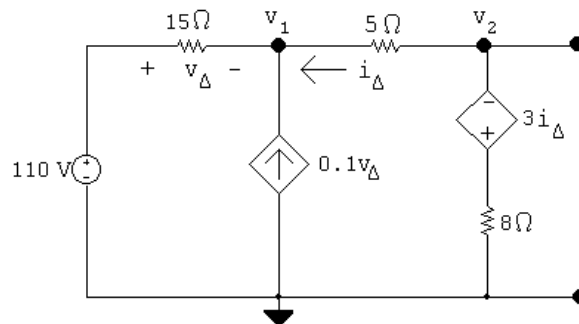

Node voltage equations:

$$\frac{v_1 - 110}{15} - 0.1v_\Delta + \frac{v_1 - v_2}{5} = 0$$

$$\frac{v_2 - v_1}{5} + \frac{v_2 + 3i_\Delta}{8} = 0$$

Constraint equations:

$$i_\Delta = \frac{v_2 - v_1}{5}; \quad v_\Delta = 110 - v_1$$

Solving, $v_2 = 55 \text{ V} = v_{\text{Th}}$

Thévenin resistance using a test source:

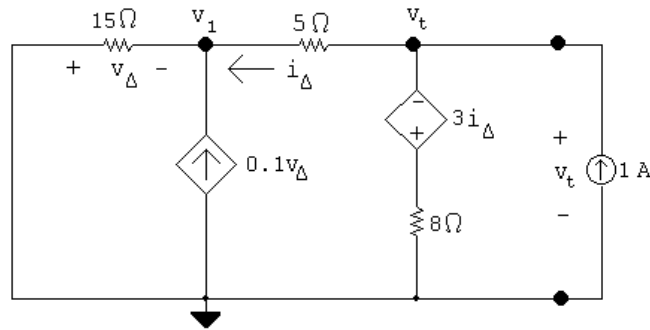

$$\frac{v_1}{15} - 0.1v_\Delta + \frac{v_1 - v_t}{5} = 0$$

$$\frac{v_t - v_1}{5} + \frac{v_t + 3i_\Delta}{8} - 1 = 0$$

$$i_\Delta = \frac{v_t - v_1}{5}; \quad v_\Delta = -v_1$$

Solving, $v_t = 4 \text{ V}$.

$$R_{\text{Th}} = \frac{v_t}{1} = 4 \Omega$$

$$\therefore R_o = R_{\text{Th}} = 4 \Omega$$

[b]

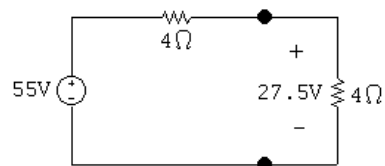

$$p_{\text{max}} = \frac{(27.5)^2}{4} = 189.0625 \text{ W}$$

[c]

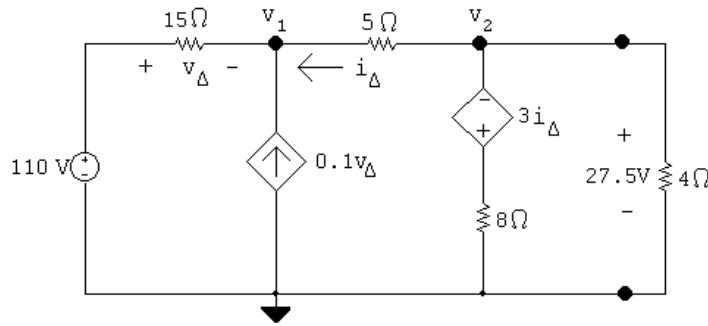

$$\frac{v_1 - 110}{15} - 0.1v_\Delta + \frac{v_1 - 27.5}{5} = 0$$

$$v_\Delta = 110 - v_1$$

Solving, $v_1 = 65$ V,

$$i_{110V} = \frac{65 - 110}{15} = -3 \text{ A}$$

$$p_{110V} = 110(-3) = -330 \text{ W}$$

$$i_\Delta = \frac{27.5 - 65}{5} = -7.5 \text{ A}$$

$$i_{CCVS} = \frac{27.5 + 3i_\Delta}{8} = 0.625 \text{ A}$$

$$p_{CCVS} = -[3(-7.5)](0.625) = 14.0625 \text{ W}$$

$$p_{VCCS} = -[0.1(45)](65) = -292.5 \text{ W}$$

$$\sum p_{\text{dev}} = 330 + 292.5 = 622.5 \text{ W}$$

$$\% \text{ delivered} = \frac{189.0625}{622.5} \times 100 = 30.37\%$$

P 4.88 We begin by finding the Thévenin equivalent with respect to R_o . After making a couple of source transformations the circuit simplifies to

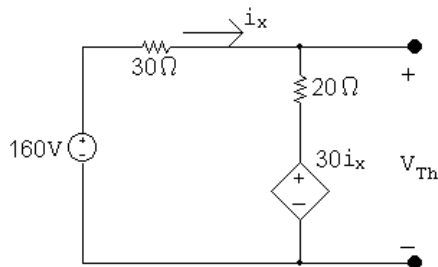

$$i_\Delta = \frac{160 - 30i_\Delta}{50}; \quad i_\Delta = 2 \text{ A}$$

$$V_{Th} = 20i_{\Delta} + 30i_{\Delta} = 50i_{\Delta} = 100 \text{ V}$$

Using the test-source method to find the Thévenin resistance gives

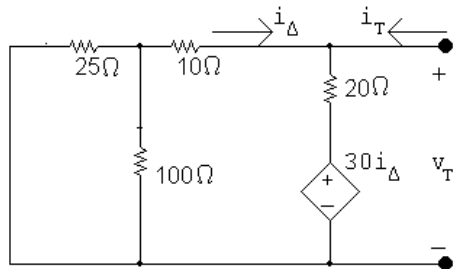

$$i_T = \frac{v_T}{30} + \frac{v_T - 30(-v_T/30)}{20}$$

$$\frac{i_T}{v_T} = \frac{1}{30} + \frac{1}{10} = \frac{4}{30} = \frac{2}{15}$$

$$R_{Th} = \frac{v_T}{i_T} = \frac{15}{2} = 7.5 \Omega$$

Thus our problem is reduced to analyzing the circuit shown below.

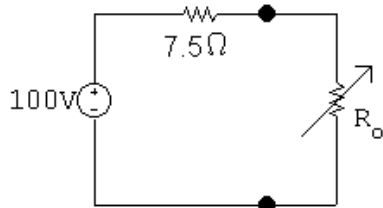

$$p = \left(\frac{100}{7.5 + R_o} \right)^2 R_o = 250$$

$$\frac{10^4}{R_o^2 + 15R_o + 56.25} R_o = 250$$

$$\frac{10^4 R_o}{250} = R_o^2 + 15R_o + 56.25$$

$$40R_o = R_o^2 + 15R_o + 56.25$$

$$R_o^2 - 25R_o + 56.25 = 0$$

$$R_o = 12.5 \pm \sqrt{156.25 - 56.25} = 12.5 \pm 10$$

$$R_o = 22.5 \Omega$$

$$R_o = 2.5 \Omega$$

P 4.89 [a] First find the Thévenin equivalent with respect to R_o .

Open circuit voltage: $i_\phi = 0$; $184i_\phi = 0$

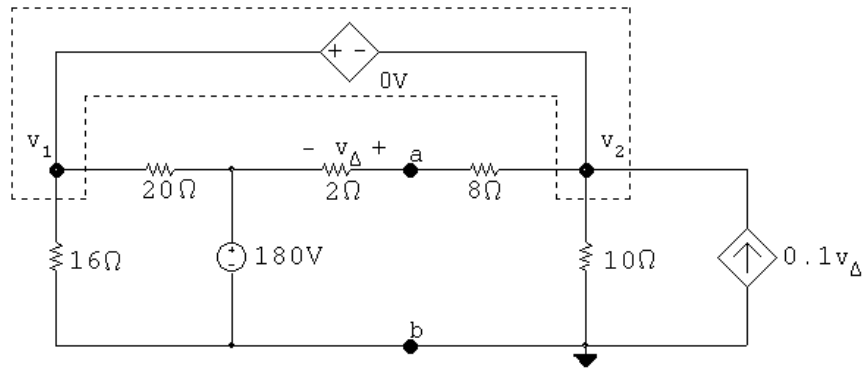

$$\frac{v_1}{16} + \frac{v_1 - 180}{20} + \frac{v_1 - 180}{10} + \frac{v_1}{10} - 0.1v_\Delta = 0$$

$$v_\Delta = \frac{v_1 - 180}{10}(2) = 0.2v_1 - 36$$

$$v_1 = 80 \text{ V}; \quad v_\Delta = -20 \text{ V}$$

$$V_{Th} = 180 + v_\Delta = 180 - 20 = 160 \text{ V}$$

Short circuit current

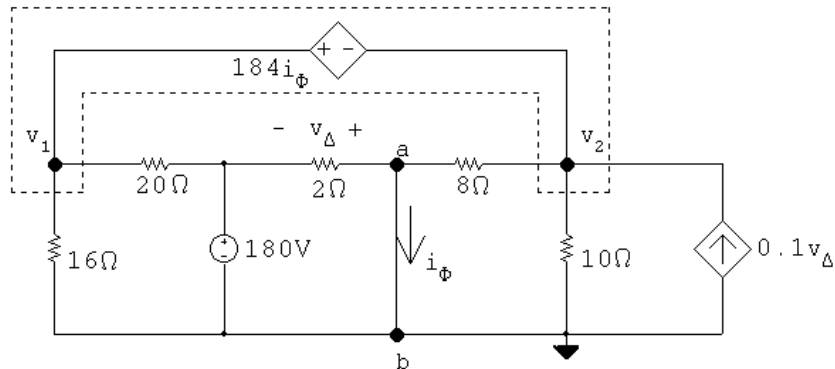

$$\frac{v_1}{16} + \frac{v_1 - 180}{20} + \frac{v_2}{8} + \frac{v_2}{10} - 0.1(-180) = 0$$

$$v_2 + 184i_\phi = v_1$$

$$i_\phi = \frac{180}{2} + \frac{v_2}{8} = 90 + 0.125v_2$$

$$v_2 = -640 \text{ V}; \quad v_1 = 1200 \text{ V}$$

$$i_\phi = i_{sc} = 10 \text{ A}$$

$$R_{Th} = V_{Th}/i_{sc} = 160/10 = 16 \Omega$$

$$\therefore R_o = 16 \Omega$$

[b]

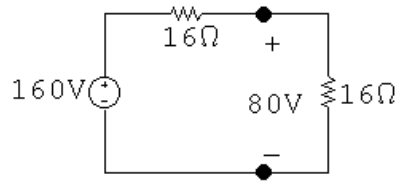

$$p_{\max} = (80)^2/16 = 400 \text{ W}$$

[c]

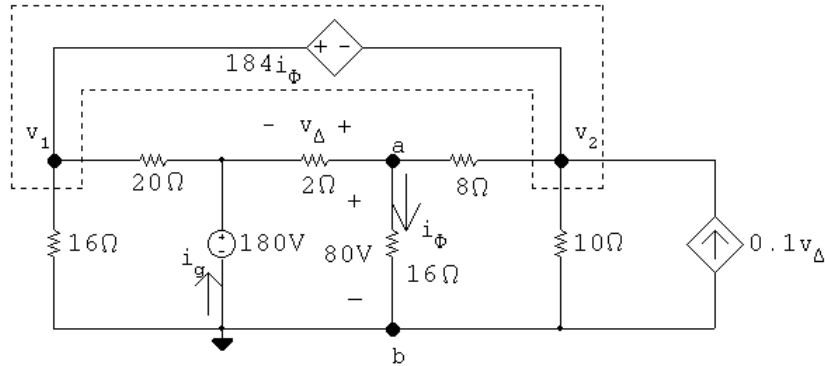

$$\frac{v_1}{16} + \frac{v_1 - 180}{20} + \frac{v_2 - 80}{8} + \frac{v_2}{10} - 0.1(80 - 180) = 0$$

$$v_2 + 184i_\phi = v_1; \quad i_\phi = 80/16 = 5 \text{ A}$$

Therefore, $v_1 = 640 \text{ V}$ and $v_2 = -280 \text{ V}$; thus,

$$i_g = \frac{180 - 80}{2} + \frac{180 - 640}{20} = 27 \text{ A}$$

$$p_{180\text{V}} (\text{dev}) = (180)(27) = 4860 \text{ W}$$

P 4.90 [a] Find the Thévenin equivalent with respect to the terminals of R_L .
Open circuit voltage:

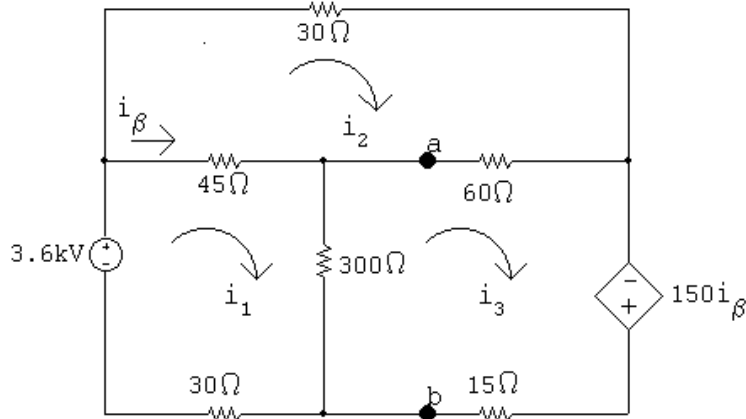

The mesh current equations are:

$$\begin{aligned}
 -3600 + 45(i_1 - i_2) + 300(i_1 - i_3) + 30i_1 &= 0 \\
 30i_2 + 60(i_2 - i_3) + 45(i_2 - i_1) &= 0 \\
 -150i_\beta + 15i_3 + 300(i_3 - i_1) + 60(i_3 - i_2) &= 0
 \end{aligned}$$

The dependent source constraint equation is:

$$i_\beta = i_1 - i_2$$

Place these equations in standard form:

$$\begin{aligned}
 i_1(45 + 300 + 30) + i_2(-45) + i_3(-300) + i_\beta(0) &= 3600 \\
 i_1(-45) + i_2(30 + 60 + 45) + i_3(-60) + i_\beta(0) &= 0 \\
 i_1(-300) + i_2(-60) + i_3(15 + 300 + 60) + i_\beta(-150) &= 0 \\
 i_1(1) + i_2(-1) + i_3(0) + i_\beta(-1) &= 0
 \end{aligned}$$

Solving, $i_1 = 99.6 \text{ A}$; $i_2 = 78 \text{ A}$; $i_3 = 100.8 \text{ A}$; $i_\beta = 21.6 \text{ A}$

$$V_{Th} = 300(i_1 - i_3) = -360 \text{ V}$$

Short-circuit current:

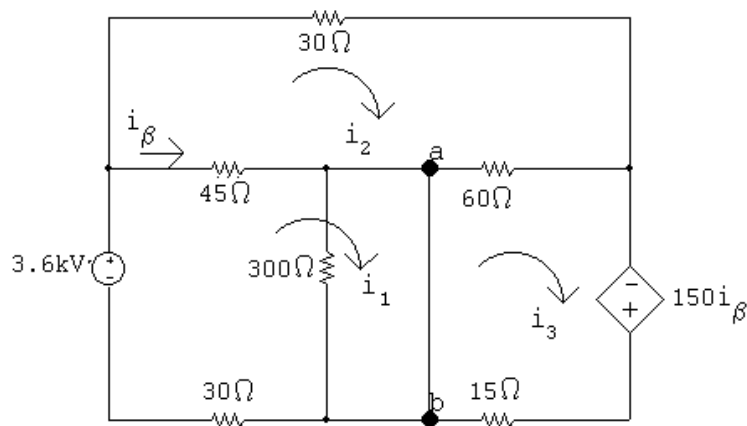

The mesh current equations are:

$$\begin{aligned}
 -3600 + 45(i_1 - i_2) + 30i_1 &= 0 \\
 30i_2 + 60(i_2 - i_3) + 45(i_2 - i_1) &= 0 \\
 -150i_\beta + 15i_3 + 60(i_3 - i_2) &= 0
 \end{aligned}$$

The dependent source constraint equation is:

$$i_\beta = i_1 - i_2$$

Place these equations in standard form:

$$\begin{aligned}
 i_1(45 + 30) + i_2(-45) + i_3(0) + i_\beta(0) &= 3600 \\
 i_1(-45) + i_2(30 + 60 + 45) + i_3(-60) + i_\beta(0) &= 0 \\
 i_1(0) + i_2(-60) + i_3(60 + 15) + i_\beta(-150) &= 0 \\
 i_1(1) + i_2(-1) + i_3(0) + i_\beta(-1) &= 0
 \end{aligned}$$

Solving, $i_1 = 92 \text{ A}$; $i_2 = 73.33 \text{ A}$; $i_3 = 96 \text{ A}$; $i_\beta = 18.67 \text{ A}$

$$i_{sc} = i_1 - i_3 = -4 \text{ A}; \quad R_{Th} = \frac{V_{Th}}{i_{sc}} = \frac{-360}{-4} = 90 \Omega$$

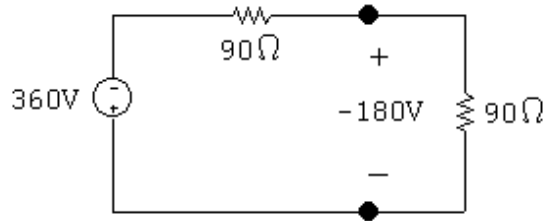

$$R_L = R_{Th} = 90 \Omega$$

[b] $p_{max} = \frac{180^2}{90} = 360 \text{ W}$

P 4.91 [a] We begin by finding the Thévenin equivalent with respect to the terminals of R_o .

Open circuit voltage

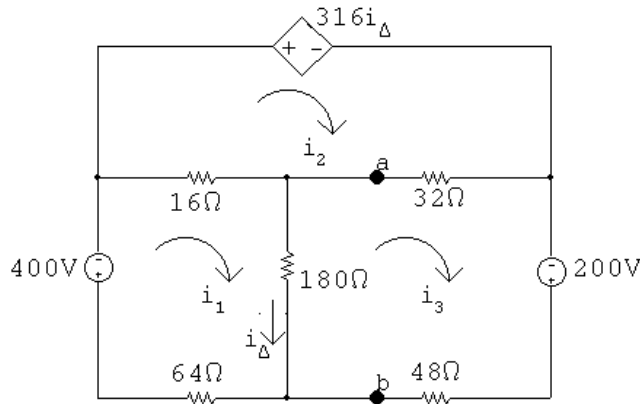

The mesh current equations are:

$$260i_1 - 16i_2 - 180i_3 = -400$$

$$-16i_1 + 48i_2 - 32i_3 + 316(i_1 - i_3) = 0$$

$$-180i_1 - 32i_2 + 260i_3 = 200$$

Solving, $i_1 = 3 \text{ A}; \quad i_2 = 17.5 \text{ A}; \quad i_3 = 5 \text{ A}; \quad i_{\Delta} = i_1 - i_3 = -2 \text{ A}$

Also, $V_{Th} = v_{oc} = 180i_{\Delta} = -360 \text{ V}$

Now find the short-circuit current.

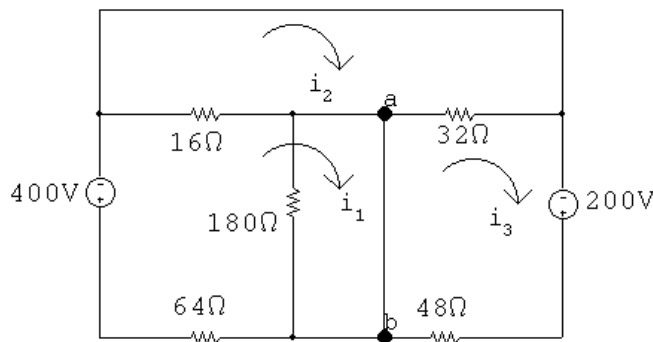

Note with the short circuit from a to b that i_{Δ} is zero, hence $316i_{\Delta}$ is also zero.

The mesh currents are:

$$80i_1 - 16i_2 + 0i_3 = -400$$

$$-16i_1 + 48i_2 - 32i_3 = 0$$

$$0i_1 - 32i_2 + 80i_3 = 200$$

Solving, $i_1 = -5 \text{ A}$; $i_2 = 0 \text{ A}$; $i_3 = 2.5 \text{ A}$

Then, $i_{sc} = i_1 - i_3 = -7.5 \text{ A}$

$$R_{Th} = \frac{-360}{-7.5} = 48 \Omega$$

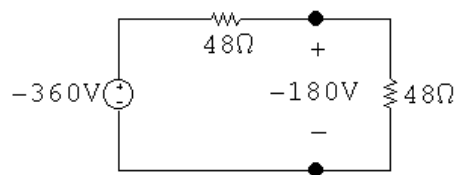

For maximum power transfer $R_o = R_{Th} = 48 \Omega$

[b] $p_{max} = \frac{180^2}{48} = 675 \text{ W}$

[c] The problem reduces to the analysis of the following circuit. In constructing the circuit we have used the fact that i_{Δ} is -1 A , and hence $316i_{\Delta}$ is -316 V .

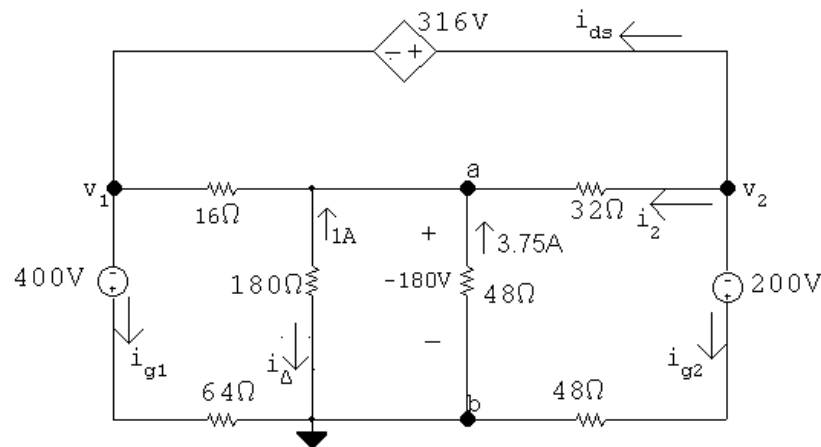

Using the node voltage method to find v_1 and v_2 yields

$$\frac{v_1 + 400}{64} + \frac{v_1 + 180}{16} + \frac{v_2 + 180}{32} + \frac{v_2 + 200}{48} = 0$$

$$v_2 - v_1 = 316$$

Solving, $v_1 = -336 \text{ V}$; $v_2 = -20 \text{ V}$.

It follows that

$$\begin{aligned} i_{g_1} &= \frac{-336 + 400}{64} = 1 \text{ A} \\ i_{g_2} &= \frac{-20 + 200}{48} = 3.75 \text{ A} \\ i_2 &= \frac{-20 + 180}{32} = 5 \text{ A} \\ i_{ds} &= -5 - 3.75 = -8.75 \text{ A} \\ p_{400V} &= -400i_{g_1} = -400 \text{ W} \\ p_{200V} &= -200i_{g_2} = -750 \text{ W} \\ p_{ds} &= 316i_{ds} = -2765 \text{ W} \end{aligned}$$

$$\therefore \sum p_{dev} = 400 + 750 + 2765 = 3915 \text{ W}$$

$$\therefore \% \text{ delivered} = \frac{675}{3915}(100) = 17.24\%$$

\therefore 17.24% of developed power is delivered to load

- [d]** The resistor from Appendix H that is closest to the Thévenin resistance is 47Ω . To calculate the power delivered to a 47Ω load resistor, calculate the current using the Thévenin circuit and use it to find the power delivered to the load resistor:

$$i_{47} = \frac{-360}{47 + 48} = 3.7895 \text{ A}$$

$$p_{47} = 47(3.7895)^2 = 674.9 \text{ W}$$

Thus, using a 47Ω resistor selected from Appendix H will cause 674.9 W of power to be delivered to the load, compared to the maximum power of 675 W that will be delivered if a 48Ω resistor is used.

P 4.92 **[a]** By hypothesis $i'_o + i''_o = 3 \text{ mA}$.

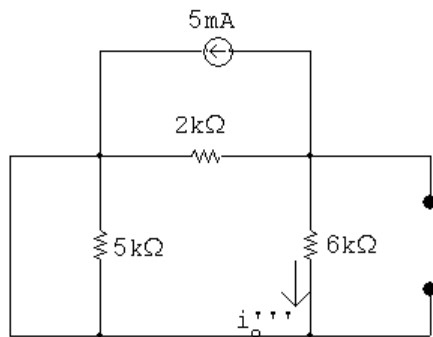

$$i'''_o = -5 \frac{(2)}{(8)} = -1.25 \text{ mA}; \quad \therefore i_o = 3.5 - 1.25 = 2.25 \text{ mA}$$

[b] With all three sources in the circuit write a single node voltage equation.

$$\frac{v_b}{6} + \frac{v_b - 8}{2} + 5 - 10 = 0$$

$$\therefore v_b = 13.5 \text{ V}$$

$$i_o = \frac{v_b}{6} = 2.25 \text{ mA}$$

P 4.93 [a] 110 V source acting alone:

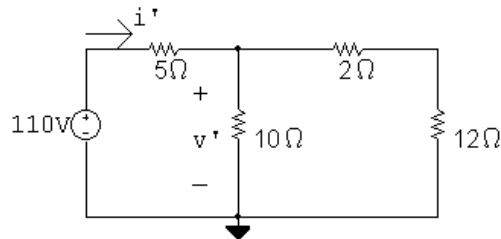

$$R_e = \frac{10(12)}{24} = \frac{35}{6} \Omega$$

$$i' = \frac{110}{5 + 35/6} = \frac{132}{13} \text{ A}$$

$$v' = \left(\frac{35}{6}\right) \left(\frac{132}{13}\right) = \frac{770}{13} \text{ V} = 59.231 \text{ V}$$

4 A source acting alone:

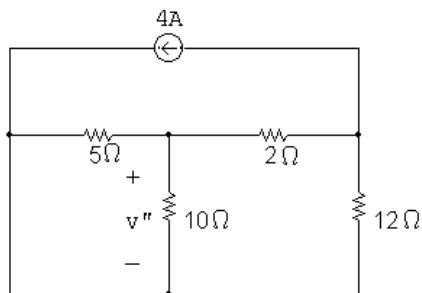

$$5 \Omega \parallel 10 \Omega = 50/15 = 10/3 \Omega$$

$$10/3 + 2 = 16/3 \Omega$$

$$16/3 \parallel 12 = 48/13 \Omega$$

Hence our circuit reduces to:

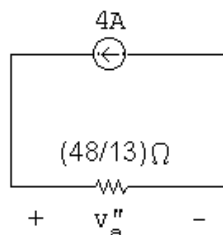

It follows that

$$v''_a = 4(48/13) = (192/13) \text{ V}$$

and

$$v'' = \frac{-v''_a}{(16/3)}(10/3) = -\frac{5}{8}v''_a = -(120/13) \text{ V} = -9.231 \text{ V}$$

$$\therefore v = v' + v'' = \frac{770}{13} - \frac{120}{13} = 50 \text{ V}$$

[b] $p = \frac{v^2}{10} = 250 \text{ W}$

P 4.94 Voltage source acting alone:

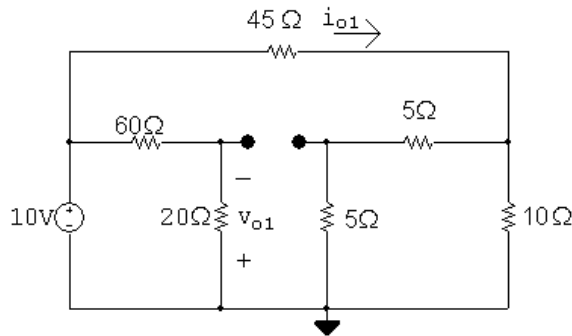

$$i_{o1} = \frac{10}{45 + (5 + 5) \parallel 10} = \frac{10}{45 + 5} = 0.2 \text{ A}$$

$$v_{o1} = \frac{20}{20 + 60}(-10) = -2.5 \text{ V}$$

Current source acting alone:

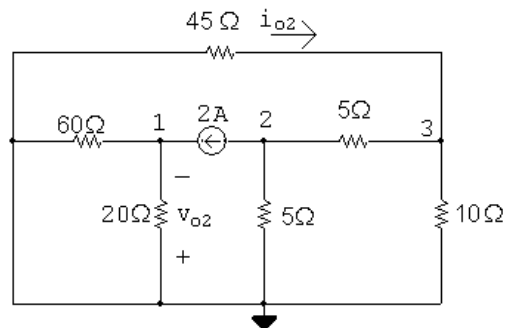

$$\frac{v_2}{5} + 2 + \frac{v_2 - v_3}{5} = 0$$

$$\frac{v_3}{10} + \frac{v_3 - v_2}{5} + \frac{v_3}{45} = 0$$

Solving, $v_2 = -7.25 \text{ V} = v_{o2}$; $v_3 = -4.5 \text{ V}$

$$i_{o2} = -\frac{v_3}{45} = -0.1 \text{ A}$$

$$i_{20} = \frac{60 \parallel 20}{20}(2) = 1.5 \text{ A}$$

$$v_{o2} = -20i_{20} = -20(1.5) = -30 \text{ V}$$

$$\therefore v_o = v_{o1} + v_{o2} = -2.5 - 30 = -32.5 \text{ V}$$

$$i_o = i_{o1} + i_{o2} = 0.2 + 0.1 = 0.3 \text{ A}$$

P 4.95 6 A source:

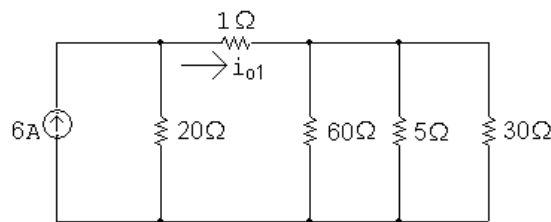

$$30 \Omega \parallel 5 \Omega \parallel 60 \Omega = 4 \Omega$$

$$\therefore i_{o1} = \frac{20}{20 + 5}(6) = 4.8 \text{ A}$$

10 A source:

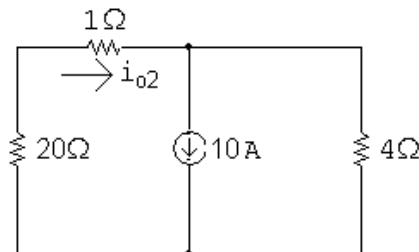

$$i_{o2} = \frac{4}{25}(10) = 1.6 \text{ A}$$

75 V source:

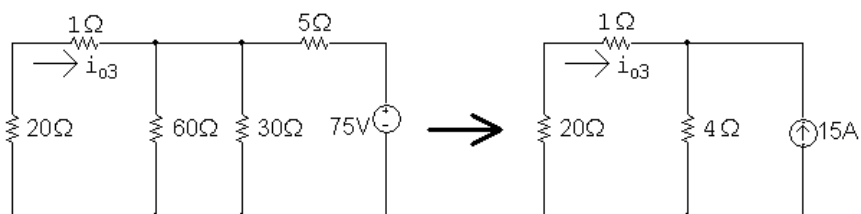

$$i_{o3} = -\frac{4}{25}(15) = -2.4 \text{ A}$$

$$i_o = i_{o1} + i_{o2} + i_{o3} = 4.8 + 1.6 - 2.4 = 4 \text{ A}$$

P 4.96 240 V source acting alone:

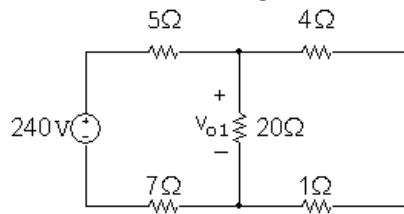

$$v_{o1} = \frac{20 \parallel 5}{5 + 7 + 20 \parallel 5} (240) = 60 \text{ V}$$

84 V source acting alone:

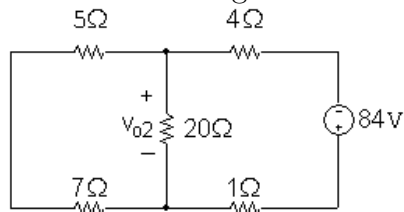

$$v_{o2} = \frac{20 \parallel 12}{1 + 4 + 20 \parallel 12} (-84) = -50.4 \text{ V}$$

16 A current source acting alone:

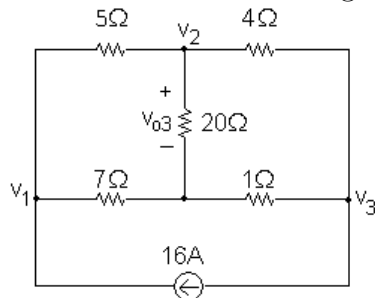

$$\frac{v_1 - v_2}{5} + \frac{v_1}{7} - 16 = 0$$

$$\frac{v_2 - v_1}{5} + \frac{v_2}{20} + \frac{v_2 - v_3}{4} = 0$$

$$\frac{v_3 - v_2}{4} + \frac{v_3}{1} + 16 = 0$$

Solving, $v_2 = 18.4 \text{ V} = v_{o3}$. Therefore,

$$v_o = v_{o1} + v_{o2} + v_{o3} = 60 - 50.4 + 18.4 = 28 \text{ V}$$

P 4.97 Voltage source acting alone:

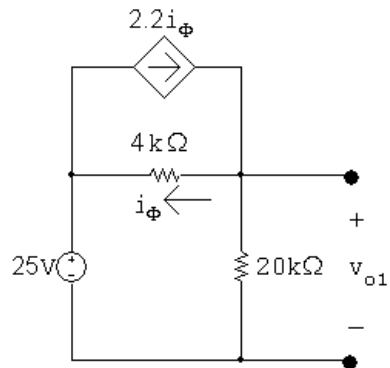

$$\frac{v_{o1} - 25}{4000} + \frac{v_{o1}}{20,000} - 2.2 \left(\frac{v_{o1} - 25}{4000} \right) = 0$$

Simplifying $5v_{o1} - 125 + v_{o1} - 11v_{o1} + 275 = 0$

$$\therefore v_{o1} = 30 \text{ V}$$

Current source acting alone:

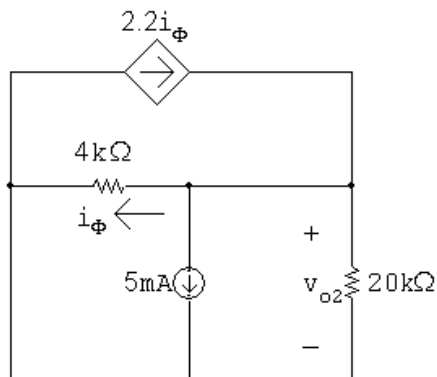

$$\frac{v_{o2}}{4000} + \frac{v_{o2}}{20,000} + 0.005 - 2.2 \left(\frac{v_{o2}}{4000} \right) = 0$$

Simplifying $5v_{o2} + v_{o2} + 100 - 11v_{o2} = 0$

$$\therefore v_{o2} = 20 \text{ V}$$

$$v_o = v_{o1} + v_{o2} = 30 + 20 = 50 \text{ V}$$

P 4.98 90-V source acting alone:

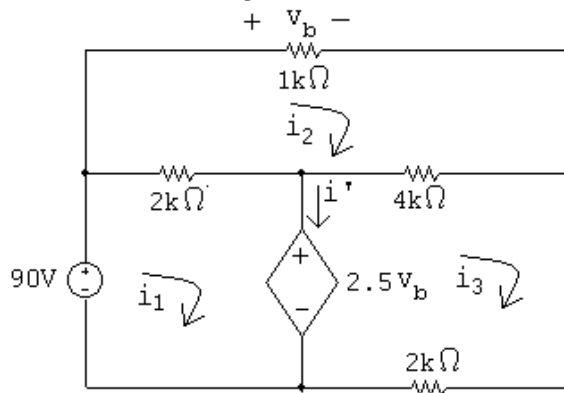

$$2000(i_1 - i_2) + 2.5v_b = 90$$

$$-2000i_1 + 7000i_2 - 4000i_3 = 0$$

$$-4000i_2 + 6000i_3 - 2.5v_b = 0$$

$$v_b = 1000i_2$$

Solving,

$$i_1 = 37.895 \text{ mA}; \quad i_3 = 30.789 \text{ mA}; \quad i' = i_1 - i_3 = 7.105 \text{ mA}$$

40-V source acting alone:

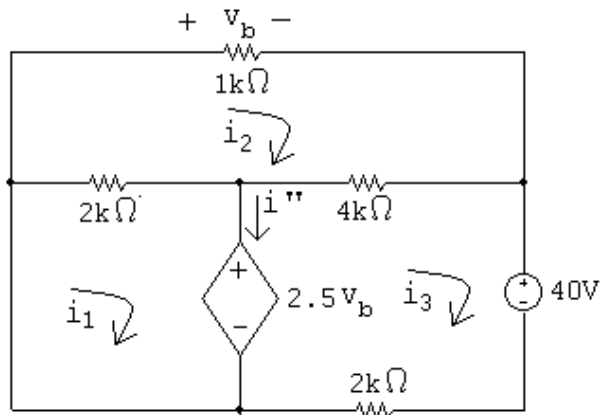

$$2000(i_1 - i_2) + 2.5v_b = 0$$

$$-2000i_1 + 7000i_2 - 4000i_3 = 0$$

$$-4000i_2 + 6000i_3 - 2.5v_b = -40$$

$$v_b = 1000i_2$$

Solving,

$$i_1 = 2.105 \text{ mA}; \quad i_3 = -15.789 \text{ mA}; \quad i'' = i_1 - i_3 = 17.895 \text{ mA}$$

$$\text{Hence, } i = i' + i'' = 7.105 + 17.895 = 25 \text{ mA}$$

P 4.99 [a] In studying the circuit in Fig. P4.99 we note it contains six meshes and six essential nodes. Further study shows that by replacing the parallel resistors with their equivalent values the circuit reduces to four meshes and four essential nodes as shown in the following diagram.

The node-voltage approach will require solving three node voltage equations along with equations involving v_x , v_y , and i_x .

The mesh-current approach will require writing one mesh equation and one supermesh equation plus five constraint equations involving the five sources. Thus at the outset we know the supermesh equation can be reduced to a single unknown current. Since we are interested in the power developed by the 50 V source, we will retain the mesh current i_b and eliminate the mesh currents i_a , i_c and i_d .

The supermesh is denoted by the dashed line in the following figure.

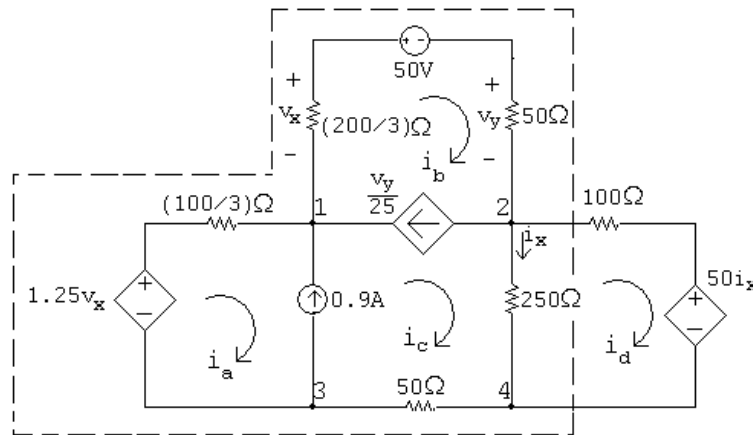

[b] Summing the voltages around the supermesh yields

$$-1.25v_x + (100/3)i_a + (200/3)i_b + 50 + 50i_b + 250(i_c - i_d) + 50i_c = 0$$

The remaining mesh equation is

$$50i_x + 350i_d - 250i_c = 0$$

The constraint equations are

$$\frac{v_y}{25} = i_b - i_c; \quad 0.9 = i_c - i_a; \quad v_x = -(200/3)i_b$$

$$v_y = 50i_b; \quad i_x = i_c - i_d$$

Solving,

$$i_a = -0.3 \text{ A}; \quad i_b = -0.6 \text{ A}; \quad i_c = 0.6 \text{ A}; \quad i_d = 0.4 \text{ A}$$

Finally,

$$p_{50\text{V}} = 50i_b = -30 \text{ W}$$

The 50 V source delivers 30 W of power.

P 4.100

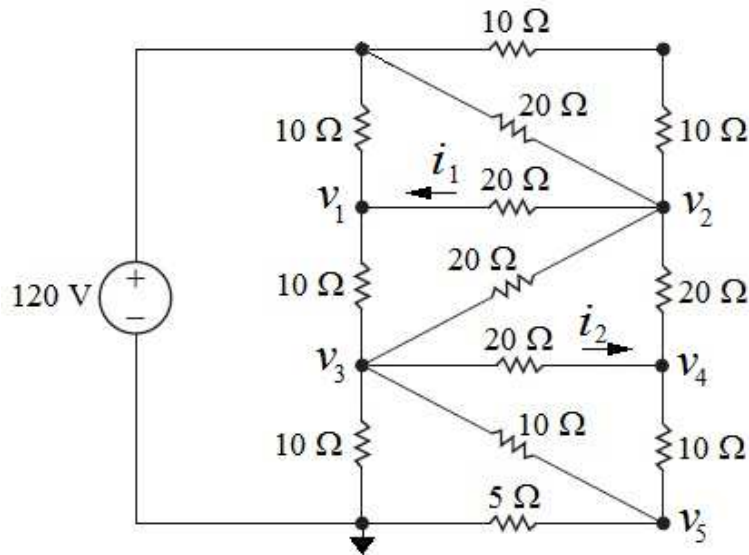

$$\text{At } v_1: \frac{v_1 - 120}{10} + \frac{v_1 - v_2}{20} + \frac{v_1 - v_3}{10} = 0$$

$$\text{At } v_2: \frac{v_2 - 120}{20} + \frac{v_2 - 120}{20} + \frac{v_2 - v_1}{20} + \frac{v_1 - v_3}{20} + \frac{v_2 - v_4}{20} = 0$$

$$\text{At } v_3: \frac{v_3 - v_1}{10} + \frac{v_3 - v_2}{20} + \frac{v_3 - v_4}{20} + \frac{v_3}{10} + \frac{v_3 - v_5}{10} = 0$$

$$\text{At } v_4: \frac{v_4 - v_2}{20} + \frac{v_4 - v_3}{20} + \frac{v_4 - v_5}{10} = 0$$

$$\text{At } v_5: \frac{v_5 - v_4}{10} + \frac{v_5 - v_3}{10} + \frac{v_5}{5} = 0$$

A calculator solution yields

$$v_1 = 80 \text{ A}; \quad v_2 = 80 \text{ A};$$

$$v_3 = 40 \text{ A}; \quad v_4 = 40 \text{ A};$$

$$v_5 = 20 \text{ A}.$$

$$\therefore i_1 = \frac{v_2 - v_1}{20} = 0 \text{ A}; \quad i_2 = \frac{v_3 - v_4}{20} = 0 \text{ A}$$

P 4.101

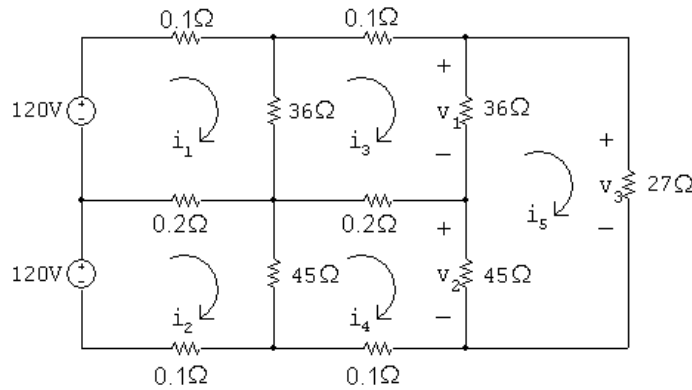

The mesh equations are:

$$\begin{aligned} i_1(36.3) + i_2(-0.2) + i_3(-36) + i_4(0) + i_5(0) &= 120 \\ i_1(-0.2) + i_2(45.3) + i_3(0) + i_4(-45) + i_5(0) &= 120 \\ i_1(-36) + i_2(0) + i_3(72.3) + i_4(-0.2) + i_5(-36) &= 0 \\ i_1(0) + i_2(-45) + i_3(-0.2) + i_4(90.3) + i_5(-45) &= 0 \\ i_1(0) + i_2(0) + i_3(-36) + i_4(-45) + i_5(108) &= 0 \end{aligned}$$

Solving,

$$i_1 = 15.226 \text{ A}; \quad i_2 = 13.953 \text{ A}; \quad i_3 = 11.942 \text{ A}; \quad i_4 = 11.314 \text{ A}; \quad i_5 = 8.695 \text{ A}$$

Find the requested voltages:

$$\begin{aligned} v_1 &= 36(i_3 - i_5) = 118.6 \text{ V} \\ v_2 &= 45(i_4 - i_5) = 117.8 \text{ V} \\ v_3 &= 27i_5 = 234.8 \text{ V} \end{aligned}$$

P 4.102 [a]

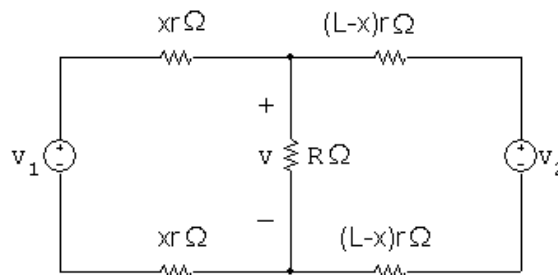

$$\begin{aligned} \frac{v - v_1}{2xr} + \frac{v}{R} + \frac{v - v_2}{2r(L - x)} &= 0 \\ v \left[\frac{1}{2xr} + \frac{1}{R} + \frac{1}{2r(L - x)} \right] &= \frac{v_1}{2xr} + \frac{v_2}{2r(L - x)} \\ v &= \frac{v_1 RL + xR(v_2 - v_1)}{RL + 2rLx - 2rx^2} \end{aligned}$$

[b] Let $D = RL + 2rLx - 2rx^2$

$$\frac{dv}{dx} = \frac{(RL + 2rLx - 2rx^2)R(v_2 - v_1) - [v_1RL + xR(v_2 - v_1)]2r(L - 2x)}{D^2}$$

$$\frac{dv}{dx} = 0 \quad \text{when numerator is zero.}$$

The numerator simplifies to

$$x^2 + \frac{2Lv_1}{(v_2 - v_1)}x + \frac{RL(v_2 - v_1) - 2rv_1L^2}{2r(v_2 - v_1)} = 0$$

Solving for the roots of the quadratic yields

$$x = \frac{L}{v_2 - v_1} \left\{ -v_1 \pm \sqrt{v_1v_2 - \frac{R}{2rL}(v_2 - v_1)^2} \right\}$$

$$[c] \quad x = \frac{L}{v_2 - v_1} \left\{ -v_1 \pm \sqrt{v_1v_2 - \frac{R}{2rL}(v_1 - v_2)^2} \right\}$$

$$v_2 = 1200 \text{ V}, \quad v_1 = 1000 \text{ V}, \quad L = 16 \text{ km}$$

$$r = 5 \times 10^{-5} \Omega/m; \quad R = 3.9 \Omega$$

$$\frac{L}{v_2 - v_1} = \frac{16,000}{1200 - 1000} = 80; \quad v_1v_2 = 1.2 \times 10^6$$

$$\frac{R}{2rL}(v_1 - v_2)^2 = \frac{3.9(-200)^2}{(10 \times 10^{-5})(16 \times 10^3)} = 0.975 \times 10^5$$

$$x = 80 \{ -1000 \pm \sqrt{1.2 \times 10^6 - 0.975 \times 10^6} \}$$

$$= 80 \{ -1000 \pm 1050 \} = 80(50) = 4000 \text{ m}$$

[d]

$$v_{\min} = \frac{v_1RL + R(v_2 - v_1)x}{RL + 2rLx - 2rx^2}$$

$$= \frac{(1000)(3.9)(16 \times 10^3) + 3.9(200)(4000)}{(3.9)(16,000) + 10 \times 10^{-5}(16,000)(4000) - 10 \times 10^{-5}(16 \times 10^6)}$$

$$= 975 \text{ V}$$

P 4.103 [a]

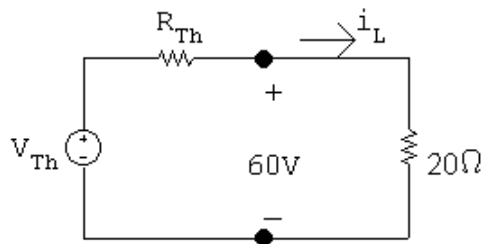

$$v_{oc} = V_{Th} = 75 \text{ V}; \quad i_L = \frac{60}{20} = 3 \text{ A}; \quad i_L = \frac{75 - 60}{R_{Th}} = \frac{15}{R_{Th}}$$

$$\text{Therefore } R_{\text{Th}} = \frac{15}{3} = 5 \Omega$$

$$[\mathbf{b}] \quad i_L = \frac{v_o}{R_L} = \frac{V_{\text{Th}} - v_o}{R_{\text{Th}}}$$

$$\text{Therefore } R_{\text{Th}} = \frac{V_{\text{Th}} - v_o}{v_o/R_L} = \left(\frac{V_{\text{Th}}}{v_o} - 1 \right) R_L$$

$$\text{P 4.104 } \frac{dv_1}{dI_{g1}} = \frac{-R_1[R_2(R_3 + R_4) + R_3R_4]}{(R_1 + R_2)(R_3 + R_4) + R_3R_4}$$

$$\frac{dv_1}{dI_{g2}} = \frac{R_1R_3R_4}{(R_1 + R_2)(R_3 + R_4) + R_3R_4}$$

$$\frac{dv_2}{dI_{g1}} + \frac{-R_1R_3R_4}{(R_1 + R_2)(R_3 + R_4) + R_3R_4}$$

$$\frac{dv_2}{dI_{g2}} = \frac{R_3R_4(R_1 + R_2)}{(R_1 + R_2)(R_3 + R_4) + R_3R_4}$$

P 4.105 From the solution to Problem 4.104 we have

$$\frac{dv_1}{dI_{g1}} = \frac{-25[5(125) + 3750]}{30(125) + 3750} = -\frac{175}{12} \text{ V/A} = -14.5833 \text{ V/A}$$

and

$$\frac{dv_2}{dI_{g1}} = \frac{-(25)(50)(75)}{30(125) + 3750} = -12.5 \text{ V/A}$$

By hypothesis, $\Delta I_{g1} = 11 - 12 = -1 \text{ A}$

$$\therefore \Delta v_1 = \left(-\frac{175}{12}\right)(-1) = \frac{175}{12} = 14.583 \text{ V}$$

Thus, $v_1 = 25 + 14.583 = 39.583 \text{ V}$

Also,

$$\Delta v_2 = (-12.5)(-1) = 12.5 \text{ V}$$

Thus, $v_2 = 90 + 12.5 = 102.5 \text{ V}$

The PSpice solution is

$$v_1 = 39.583 \text{ V}$$

and

$$v_2 = 102.5 \text{ V}$$

These values are in agreement with our predicted values.

P 4.106 From the solution to Problem 4.104 we have

$$\frac{dv_1}{dI_{g2}} = \frac{(25)(50)(75)}{30(125) + 3750} = 12.5 \text{ V/A}$$

and

$$\frac{dv_2}{dI_{g2}} = \frac{(50)(75)(30)}{30(125) + 3750} = 15 \text{ V/A}$$

By hypothesis, $\Delta I_{g2} = 17 - 16 = 1 \text{ A}$

$$\therefore \Delta v_1 = (12.5)(1) = 12.5 \text{ V}$$

Thus, $v_1 = 25 + 12.5 = 37.5 \text{ V}$

Also,

$$\Delta v_2 = (15)(1) = 15 \text{ V}$$

Thus, $v_2 = 90 + 15 = 105 \text{ V}$

The PSpice solution is

$$v_1 = 37.5 \text{ V}$$

and

$$v_2 = 105 \text{ V}$$

These values are in agreement with our predicted values.

P 4.107 From the solutions to Problems 4.104 — 4.106 we have

$$\frac{dv_1}{dI_{g1}} = -\frac{175}{12} \text{ V/A}; \quad \frac{dv_1}{dI_{g2}} = 12.5 \text{ V/A}$$

$$\frac{dv_2}{dI_{g1}} = -12.5 \text{ V/A}; \quad \frac{dv_2}{dI_{g2}} = 15 \text{ V/A}$$

By hypothesis,

$$\Delta I_{g1} = 11 - 12 = -1 \text{ A}$$

$$\Delta I_{g2} = 17 - 16 = 1 \text{ A}$$

Therefore,

$$\Delta v_1 = \frac{175}{12} + 12.5 = 27.0833 \text{ V}$$

$$\Delta v_2 = 12.5 + 15 = 27.5 \text{ V}$$

Hence

$$v_1 = 25 + 27.0833 = 52.0833 \text{ V}$$

$$v_2 = 90 + 27.5 = 117.5 \text{ V}$$

The PSpice solution is

$$v_1 = 52.0830 \text{ V}$$

and

$$v_2 = 117.5 \text{ V}$$

These values are in agreement with our predicted values.

P 4.108 By hypothesis,

$$\Delta R_1 = 27.5 - 25 = 2.5 \Omega$$

$$\Delta R_2 = 4.5 - 5 = -0.5 \Omega$$

$$\Delta R_3 = 55 - 50 = 5 \Omega$$

$$\Delta R_4 = 67.5 - 75 = -7.5 \Omega$$

So

$$\Delta v_1 = 0.5833(2.5) - 5.417(-0.5) + 0.45(5) + 0.2(-7.5) = 4.9168 \text{ V}$$

$$\therefore v_1 = 25 + 4.9168 = 29.9168 \text{ V}$$

$$\Delta v_2 = 0.5(2.5) + 6.5(-0.5) + 0.54(5) + 0.24(-7.5) = -1.1 \text{ V}$$

$$\therefore v_2 = 90 - 1.1 = 88.9 \text{ V}$$

The PSpice solution is

$$v_1 = 29.6710 \text{ V}$$

and

$$v_2 = 88.5260 \text{ V}$$

Note our predicted values are within a fraction of a volt of the actual values.