

Experiment NO.4

Digital Circuits Implementation using Breadboard

Pre Lab

Name : Mohammed Jamil Saada

ID : 1221972

- Design and implement the following circuit using gates on the chips as shown in Figure 4.1 (your final circuit must include the IC's, their pin numbers, and the connections between the pins).
- a) Build Full Adder using basic gates.

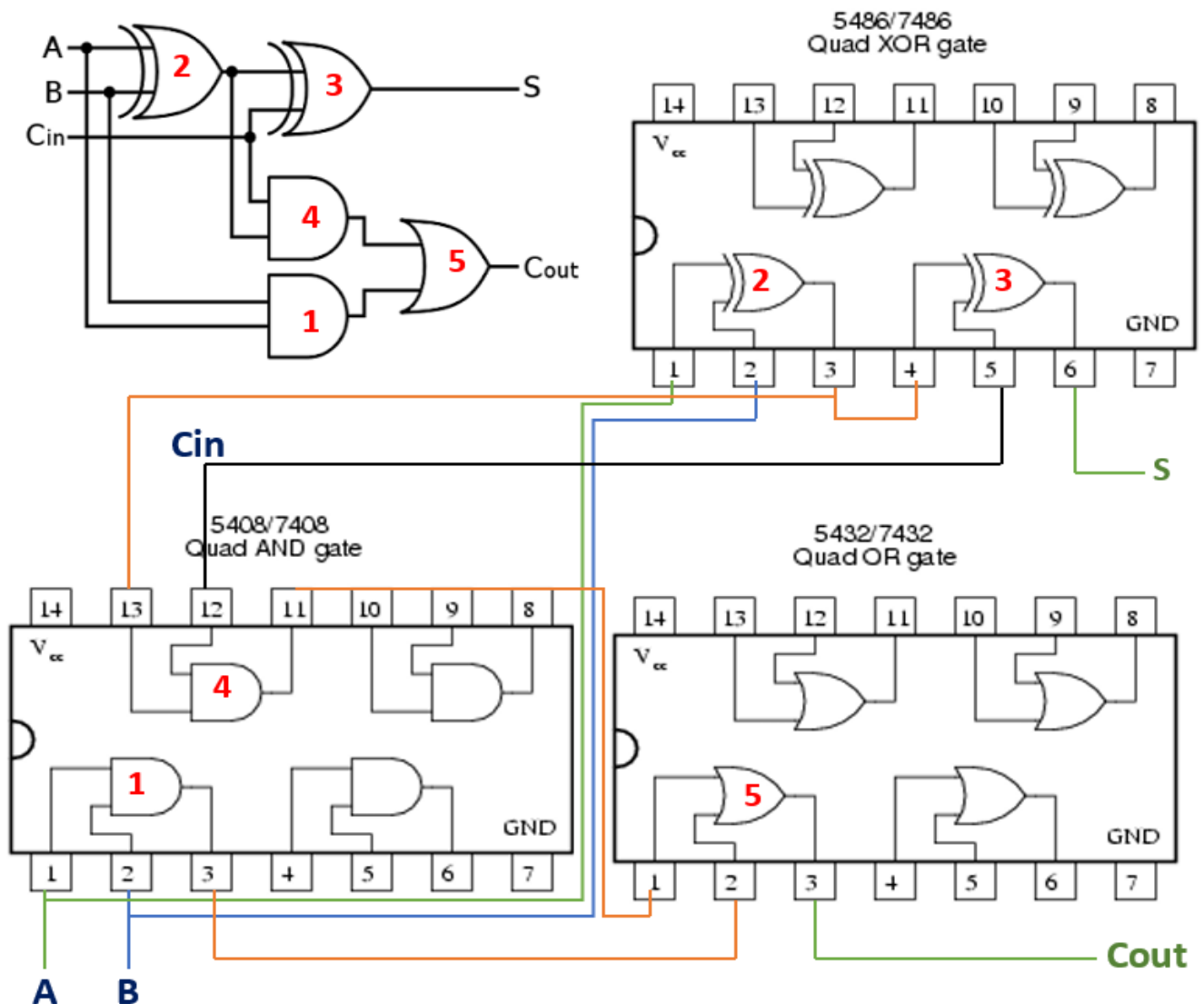

b) Build the bellow circuit using universal gates.

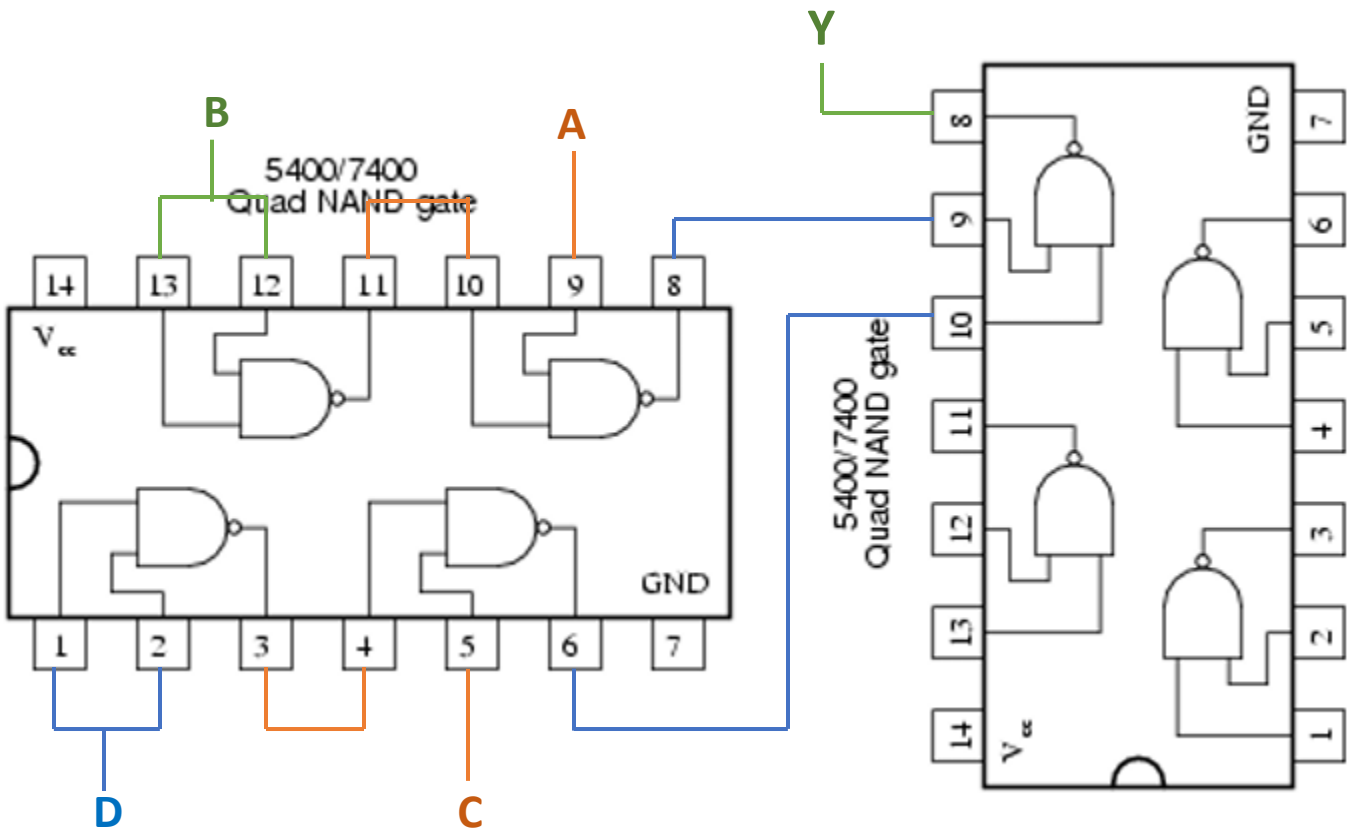
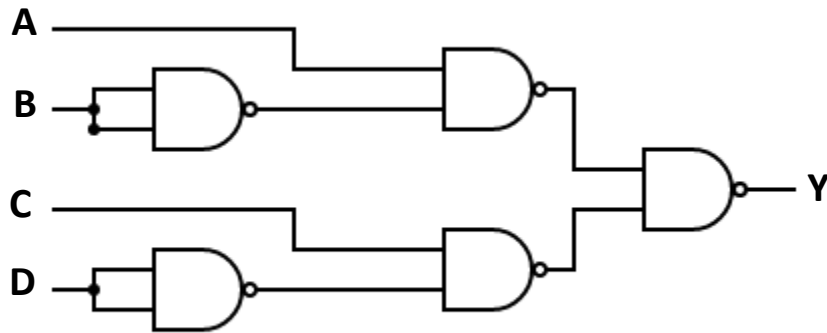
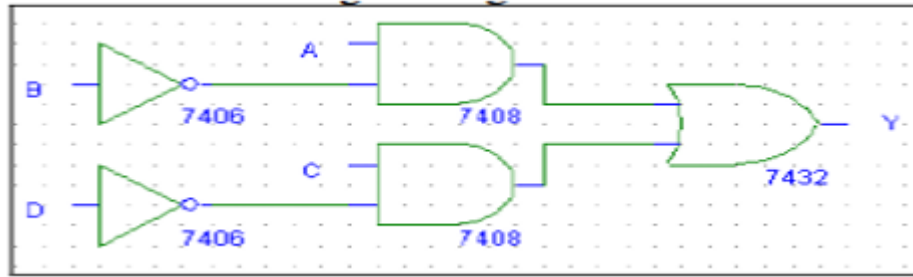

c) Build a 3x8 Decoder (active low) using basic gates.

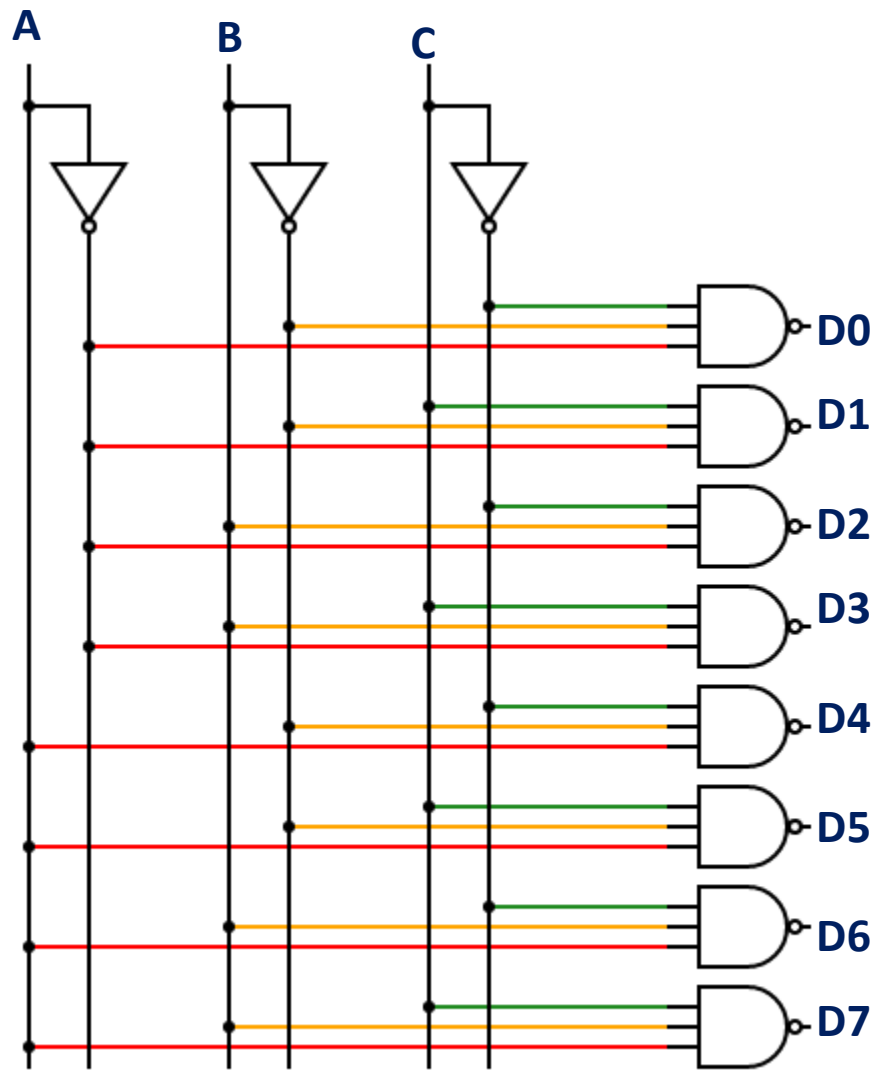

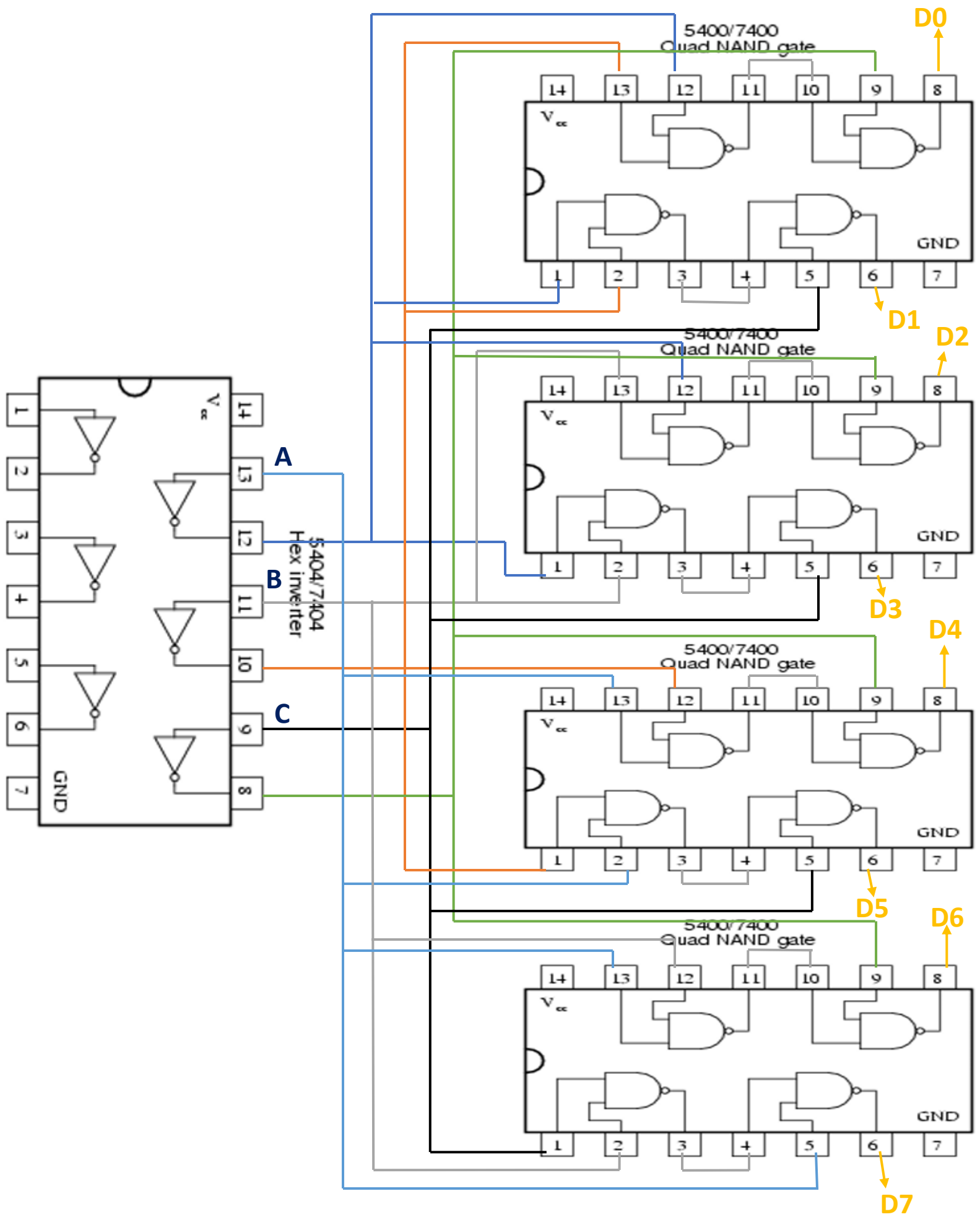

d) Build an 8x1 Multiplexer using basic gates.

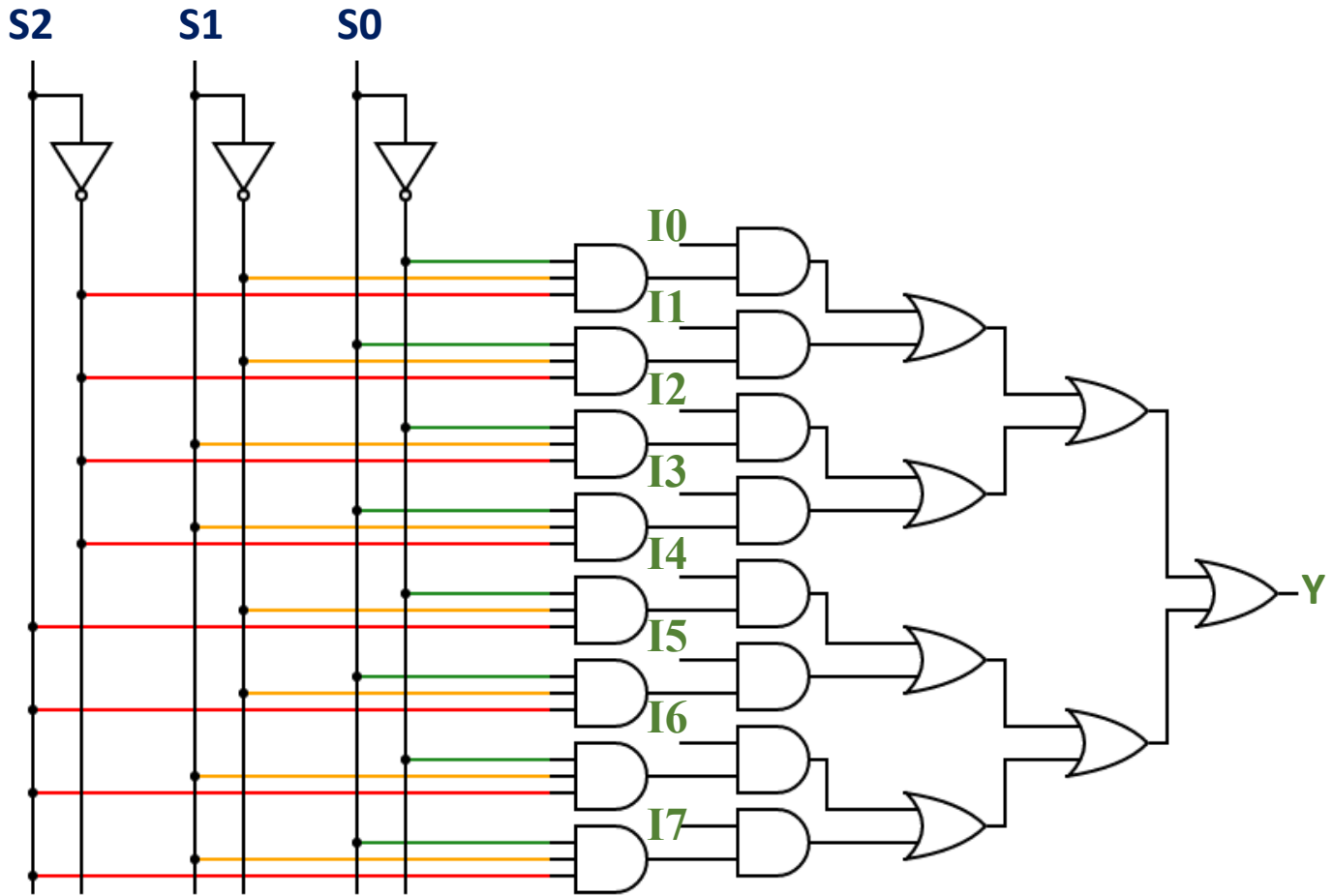

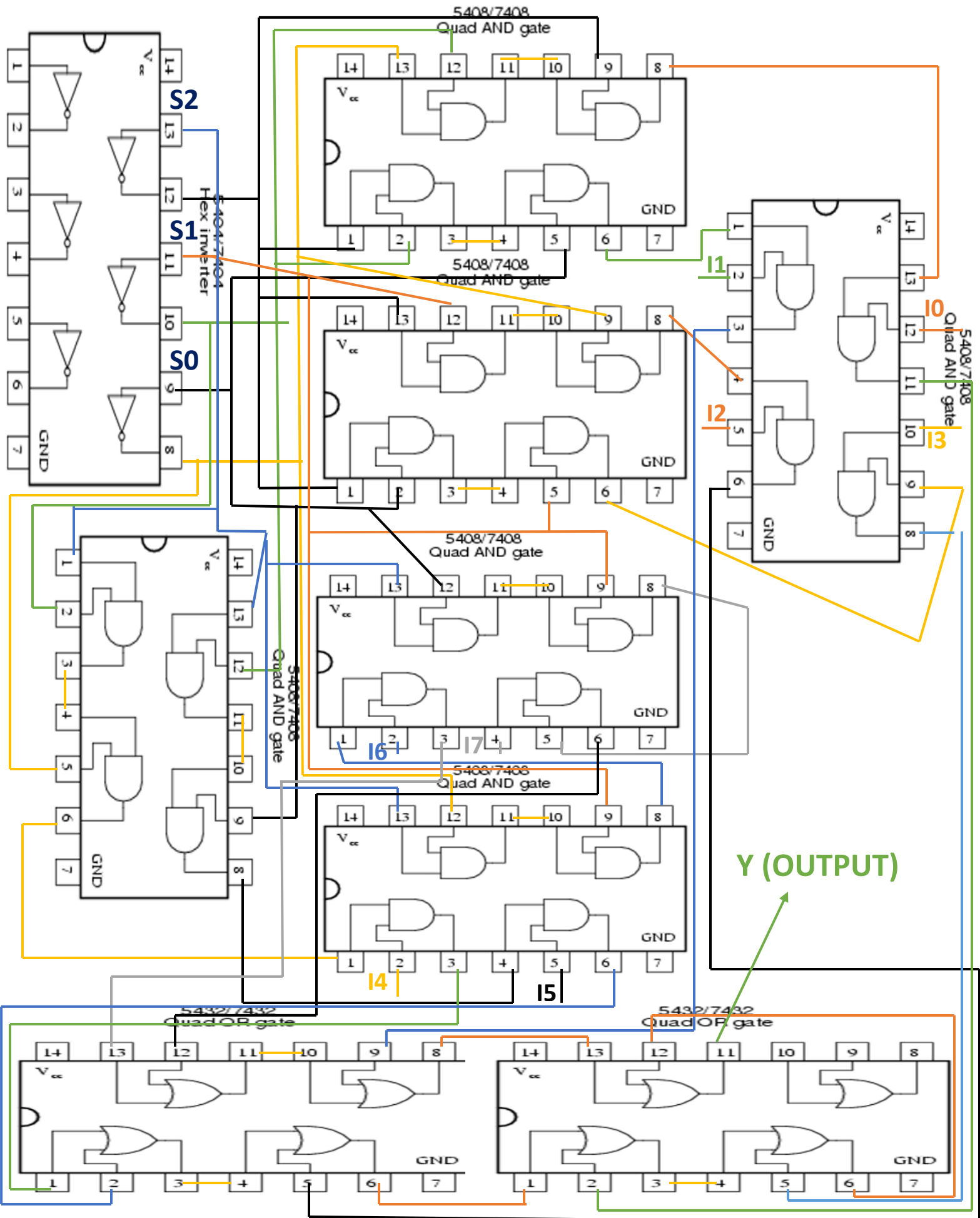

e) Use the just constructed 4x1 multiplexer to design a three input network that gives 1 if the majority of its input are 1 and output a zero otherwise.

INPUTS			OUTPUTS	
A	B	C	F	F
0	0	0	0	0
0	0	1	0	
0	1	0	0	C
0	1	1	1	
1	0	0	0	C
1	0	1	1	
1	1	0	1	1
1	1	1	1	

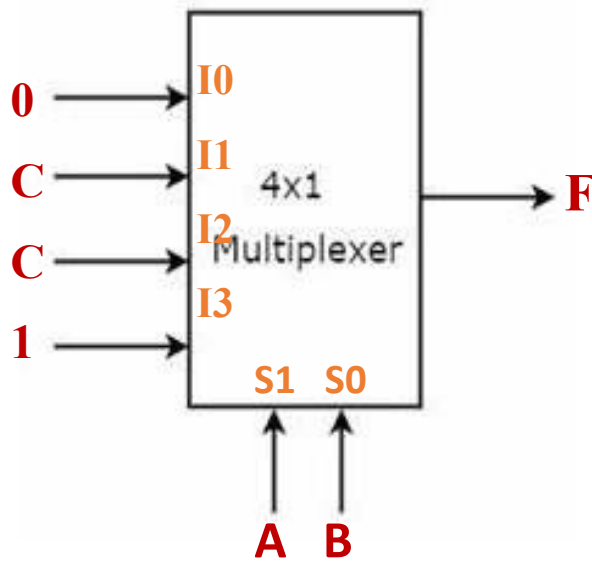

f) Use the 2x4 decoder to implement a 2 inputs function that acts like an equivalence gate (XNOR): gives 1 on the output if both inputs are equal.

INPUTS		OUTPUTS
A	B	F
0	0	1
0	1	0
1	0	0
1	1	1

$$F = \sum(0,3)$$

