Circuit Variables

Assessment Problems

AP 1.1 Use a product of ratios to convert two-thirds the speed of light from meters per second to miles per second:

$$\left(\frac{2}{3}\right) \frac{3 \times 10^8 \text{ m}}{1 \text{ s}} \cdot \frac{100 \text{ cm}}{1 \text{ m}} \cdot \frac{1 \text{ in}}{2.54 \text{ cm}} \cdot \frac{1 \text{ ft}}{12 \text{ in}} \cdot \frac{1 \text{ mile}}{5280 \text{ feet}} = \frac{124,274.24 \text{ miles}}{1 \text{ s}}$$

Now set up a proportion to determine how long it takes this signal to travel 1100 miles:

$$\frac{124,274.24 \text{ miles}}{1 \text{ s}} = \frac{1100 \text{ miles}}{x \text{ s}}$$

Therefore,

$$x = \frac{1100}{124,274.24} = 0.00885 = 8.85 \times 10^{-3} \text{ s} = 8.85 \text{ ms}$$

AP 1.2 To solve this problem we use a product of ratios to change units from dollars/year to dollars/millisecond. We begin by expressing \$10 billion in scientific notation:

$$\text{\$100 billion} = \text{\$100} \times 10^9$$

Now we determine the number of milliseconds in one year, again using a product of ratios:

$$\frac{1 \text{ year}}{365.25 \text{ days}} \cdot \frac{1 \text{ day}}{24 \text{ hours}} \cdot \frac{1 \text{ hour}}{60 \text{ mins}} \cdot \frac{1 \text{ min}}{60 \text{ secs}} \cdot \frac{1 \text{ sec}}{1000 \text{ ms}} = \frac{1 \text{ year}}{31.5576 \times 10^9 \text{ ms}}$$

Now we can convert from dollars/year to dollars/millisecond, again with a product of ratios:

$$\frac{\text{\$100} \times 10^9}{1 \text{ year}} \cdot \frac{1 \text{ year}}{31.5576 \times 10^9 \text{ ms}} = \frac{100}{31.5576} = \text{\$3.17/ms}$$

AP 1.3 Remember from Eq. (1.2), current is the time rate of change of charge, or $i = \frac{dq}{dt}$. In this problem, we are given the current and asked to find the total charge. To do this, we must integrate Eq. (1.2) to find an expression for charge in terms of current:

$$q(t) = \int_0^t i(x) dx$$

We are given the expression for current, i , which can be substituted into the above expression. To find the total charge, we let $t \rightarrow \infty$ in the integral. Thus we have

$$\begin{aligned} q_{\text{total}} &= \int_0^{\infty} 20e^{-5000x} dx = \frac{20}{-5000} e^{-5000x} \Big|_0^{\infty} = \frac{20}{-5000} (e^{-\infty} - e^0) \\ &= \frac{20}{-5000} (0 - 1) = \frac{20}{5000} = 0.004 \text{ C} = 4000 \mu\text{C} \end{aligned}$$

AP 1.4 Recall from Eq. (1.2) that current is the time rate of change of charge, or $i = \frac{dq}{dt}$. In this problem we are given an expression for the charge, and asked to find the maximum current. First we will find an expression for the current using Eq. (1.2):

$$\begin{aligned} i &= \frac{dq}{dt} = \frac{d}{dt} \left[\frac{1}{\alpha^2} - \left(\frac{t}{\alpha} + \frac{1}{\alpha^2} \right) e^{-\alpha t} \right] \\ &= \frac{d}{dt} \left(\frac{1}{\alpha^2} \right) - \frac{d}{dt} \left(\frac{t}{\alpha} e^{-\alpha t} \right) - \frac{d}{dt} \left(\frac{1}{\alpha^2} e^{-\alpha t} \right) \\ &= 0 - \left(\frac{1}{\alpha} e^{-\alpha t} - \alpha \frac{t}{\alpha} e^{-\alpha t} \right) - \left(-\alpha \frac{1}{\alpha^2} e^{-\alpha t} \right) \\ &= \left(-\frac{1}{\alpha} + t + \frac{1}{\alpha} \right) e^{-\alpha t} \\ &= t e^{-\alpha t} \end{aligned}$$

Now that we have an expression for the current, we can find the maximum value of the current by setting the first derivative of the current to zero and solving for t :

$$\frac{di}{dt} = \frac{d}{dt} (t e^{-\alpha t}) = e^{-\alpha t} + t(-\alpha) e^{-\alpha t} = (1 - \alpha t) e^{-\alpha t} = 0$$

Since $e^{-\alpha t}$ never equals 0 for a finite value of t , the expression equals 0 only when $(1 - \alpha t) = 0$. Thus, $t = 1/\alpha$ will cause the current to be maximum. For this value of t , the current is

$$i = \frac{1}{\alpha} e^{-\alpha/\alpha} = \frac{1}{\alpha} e^{-1}$$

Remember in the problem statement, $\alpha = 0.03679$. Using this value for α ,

$$i = \frac{1}{0.03679}e^{-1} \cong 10 \text{ A}$$

AP 1.5 Start by drawing a picture of the circuit described in the problem statement:

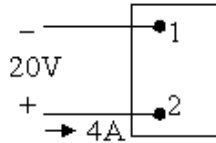

Also sketch the four figures from Fig. 1.6:

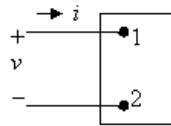

(a)

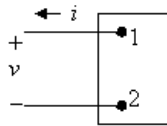

(b)

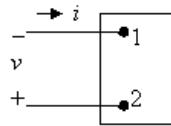

(c)

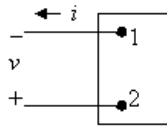

(d)

[a] Now we have to match the voltage and current shown in the first figure with the polarities shown in Fig. 1.6. Remember that 4A of current entering Terminal 2 is the same as 4A of current leaving Terminal 1. We get

$$(a) v = -20 \text{ V}, \quad i = -4 \text{ A}; \quad (b) v = -20 \text{ V}, \quad i = 4 \text{ A}$$

$$(c) v = 20 \text{ V}, \quad i = -4 \text{ A}; \quad (d) v = 20 \text{ V}, \quad i = 4 \text{ A}$$

[b] Using the reference system in Fig. 1.6(a) and the passive sign convention, $p = vi = (-20)(-4) = 80 \text{ W}$. Since the power is greater than 0, the box is absorbing power.

[c] From the calculation in part (b), the box is absorbing 80 W.

AP 1.6 [a] Applying the passive sign convention to the power equation using the voltage and current polarities shown in Fig. 1.5, $p = vi$. To find the time at which the power is maximum, find the first derivative of the power with respect to time, set the resulting expression equal to zero, and solve for time:

$$p = (80,000te^{-500t})(15te^{-500t}) = 120 \times 10^4 t^2 e^{-1000t}$$

$$\frac{dp}{dt} = 240 \times 10^4 te^{-1000t} - 120 \times 10^7 t^2 e^{-1000t} = 0$$

Therefore,

$$240 \times 10^4 - 120 \times 10^7 t = 0$$

Solving,

$$t = \frac{240 \times 10^4}{120 \times 10^7} = 2 \times 10^{-3} = 2 \text{ ms}$$

- [b] The maximum power occurs at 2 ms, so find the value of the power at 2 ms:

$$p(0.002) = 120 \times 10^4 (0.002)^2 e^{-2} = 649.6 \text{ mW}$$

- [c] From Eq. (1.3), we know that power is the time rate of change of energy, or $p = dw/dt$. If we know the power, we can find the energy by integrating Eq. (1.3). To find the total energy, the upper limit of the integral is infinity:

$$\begin{aligned} w_{\text{total}} &= \int_0^{\infty} 120 \times 10^4 x^2 e^{-1000x} dx \\ &= \frac{120 \times 10^4}{(-1000)^3} e^{-1000x} [(-1000)^2 x^2 - 2(-1000)x + 2] \Big|_0^{\infty} \\ &= 0 - \frac{120 \times 10^4}{(-1000)^3} e^0 (0 - 0 + 2) = 2.4 \text{ mJ} \end{aligned}$$

- AP 1.7 At the Oregon end of the line the current is leaving the upper terminal, and thus entering the lower terminal where the polarity marking of the voltage is negative. Thus, using the passive sign convention, $p = -vi$. Substituting the values of voltage and current given in the figure,

$$p = -(800 \times 10^3)(1.8 \times 10^3) = -1440 \times 10^6 = -1440 \text{ MW}$$

Thus, because the power associated with the Oregon end of the line is negative, power is being generated at the Oregon end of the line and transmitted by the line to be delivered to the California end of the line.

Chapter Problems

$$P 1.1 \quad \frac{(260 \times 10^6)(540)}{10^9} = 104.4 \text{ gigawatt-hours}$$

$$P 1.2 \quad \frac{(480)(320) \text{ pixels}}{1 \text{ frame}} \cdot \frac{2 \text{ bytes}}{1 \text{ pixel}} \cdot \frac{30 \text{ frames}}{1 \text{ sec}} = 9.216 \times 10^6 \text{ bytes/sec}$$

$$(9.216 \times 10^6 \text{ bytes/sec})(x \text{ secs}) = 32 \times 2^{30} \text{ bytes}$$

$$x = \frac{32 \times 2^{30}}{9.216 \times 10^6} = 3728 \text{ sec} = 62 \text{ min} \approx 1 \text{ hour of video}$$

$$P 1.3 \quad [a] \quad \frac{20,000 \text{ photos}}{(11)(15)(1) \text{ mm}^3} = \frac{x \text{ photos}}{1 \text{ mm}^3}$$

$$x = \frac{(20,000)(1)}{(11)(15)(1)} = 121 \text{ photos}$$

$$[b] \quad \frac{16 \times 2^{30} \text{ bytes}}{(11)(15)(1) \text{ mm}^3} = \frac{x \text{ bytes}}{(0.2)^3 \text{ mm}^3}$$

$$x = \frac{(16 \times 2^{30})(0.008)}{(11)(15)(1)} = 832,963 \text{ bytes}$$

$$P 1.4 \quad (4 \text{ cond.}) \cdot (845 \text{ mi}) \cdot \frac{5280 \text{ ft}}{1 \text{ mi}} \cdot \frac{2526 \text{ lb}}{1000 \text{ ft}} \cdot \frac{1 \text{ kg}}{2.2 \text{ lb}} = 20.5 \times 10^6 \text{ kg}$$

$$P 1.5 \quad \text{Volume} = \text{area} \times \text{thickness}$$

$$\text{Convert values to millimeters, noting that } 10 \text{ m}^2 = 10^6 \text{ mm}^2$$

$$10^6 = (10 \times 10^6)(\text{thickness})$$

$$\Rightarrow \text{thickness} = \frac{10^6}{10 \times 10^6} = 0.10 \text{ mm}$$

P 1.6 [a] We can set up a ratio to determine how long it takes the bamboo to grow $10 \mu\text{m}$. First, recall that $1 \text{ mm} = 10^3 \mu\text{m}$. Let's also express the rate of growth of bamboo using the units mm/s instead of mm/day . Use a product of ratios to perform this conversion:

$$\frac{250 \text{ mm}}{1 \text{ day}} \cdot \frac{1 \text{ day}}{24 \text{ hours}} \cdot \frac{1 \text{ hour}}{60 \text{ min}} \cdot \frac{1 \text{ min}}{60 \text{ sec}} = \frac{250}{(24)(60)(60)} = \frac{10}{3456} \text{ mm/s}$$

Use a ratio to determine the time it takes for the bamboo to grow $10 \mu\text{m}$:

$$\frac{10/3456 \times 10^{-3} \text{ m}}{1 \text{ s}} = \frac{10 \times 10^{-6} \text{ m}}{x \text{ s}} \quad \text{so} \quad x = \frac{10 \times 10^{-6}}{10/3456 \times 10^{-3}} = 3.456 \text{ s}$$

$$[b] \frac{1 \text{ cell length}}{3.456 \text{ s}} \cdot \frac{3600 \text{ s}}{1 \text{ hr}} \cdot \frac{(24)(7) \text{ hr}}{1 \text{ week}} = 175,000 \text{ cell lengths/week}$$

P 1.7 [a] First we use Eq. (1.2) to relate current and charge:

$$i = \frac{dq}{dt} = 0.125e^{-2500t}$$

$$\text{Therefore, } dq = 0.125e^{-2500t} dt$$

To find the charge, we can integrate both sides of the last equation. Note that we substitute x for q on the left side of the integral, and y for t on the right side of the integral:

$$\int_{q(0)}^{q(t)} dx = 0.125 \int_0^t e^{-2500y} dy$$

We solve the integral and make the substitutions for the limits of the integral:

$$q(t) - q(0) = 0.125 \frac{e^{-2500y}}{-2500} \Big|_0^t = 50 \times 10^{-6} (1 - e^{-2500t})$$

But $q(0) = 0$ by hypothesis, so

$$q(t) = 50(1 - e^{-2500t}) \mu\text{C}$$

[b] As $t \rightarrow \infty$, $q_T = 50 \mu\text{C}$.

$$[c] q(0.5 \times 10^{-3}) = (50 \times 10^{-6})(1 - e^{(-2500)(0.0005)}) = 35.675 \mu\text{C}.$$

P 1.8 First we use Eq. (1.2) to relate current and charge:

$$i = \frac{dq}{dt} = 20 \cos 5000t$$

$$\text{Therefore, } dq = 20 \cos 5000t dt$$

To find the charge, we can integrate both sides of the last equation. Note that we substitute x for q on the left side of the integral, and y for t on the right side of the integral:

$$\int_{q(0)}^{q(t)} dx = 20 \int_0^t \cos 5000y dy$$

We solve the integral and make the substitutions for the limits of the integral, remembering that $\sin 0 = 0$:

$$q(t) - q(0) = 20 \frac{\sin 5000y}{5000} \Big|_0^t = \frac{20}{5000} \sin 5000t - \frac{20}{5000} \sin 5000(0) = \frac{20}{5000} \sin 5000t$$

But $q(0) = 0$ by hypothesis, i.e., the current passes through its maximum value at $t = 0$, so $q(t) = 4 \times 10^{-3} \sin 5000t \text{ C} = 4 \sin 5000t \text{ mC}$

P 1.9 [a] First we use Eq. (1.2) to relate current and charge:

$$i = \frac{dq}{dt} = 40te^{-500t}$$

$$\text{Therefore, } dq = 40te^{-500t} dt$$

To find the charge, we can integrate both sides of the last equation. Note that we substitute x for q on the left side of the integral, and y for t on the right side of the integral:

$$\int_{q(0)}^{q(t)} dx = 40 \int_0^t ye^{-500y} dy$$

We solve the integral and make the substitutions for the limits of the integral:

$$\begin{aligned} q(t) - q(0) &= 40 \frac{e^{-500y}}{(-500)^2} (-500y - 1) \Big|_0^t = 160 \times 10^{-6} e^{-500t} (-500t - 1) + 160 \times 10^{-6} \\ &= 160 \times 10^{-6} (1 - 500te^{-500t} - e^{-500t}) \end{aligned}$$

But $q(0) = 0$ by hypothesis, so

$$q(t) = 160(1 - 500te^{-500t} - e^{-500t}) \mu\text{C}$$

$$\text{[b] } q(0.001) = (160)[1 - 500(0.001)e^{-500(0.001)} - e^{-500(0.001)}] = 14.4 \mu\text{C}.$$

$$\text{P 1.10 } n = \frac{35 \times 10^{-6} \text{ C/s}}{1.6022 \times 10^{-19} \text{ C/elec}} = 2.18 \times 10^{14} \text{ elec/s}$$

$$\text{P 1.11 } w = qV = (1.6022 \times 10^{-19})(6) = 9.61 \times 10^{-19} = 0.961 \text{ aJ}$$

P 1.12 [a]

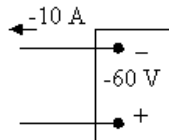

$$p = vi = (40)(-10) = -400 \text{ W}$$

Power is being delivered by the box.

[b] Entering

[c] Gaining

P 1.13 [a] $p = vi = (-60)(-10) = 600 \text{ W}$, so power is being absorbed by the box.

[b] Entering

[c] Losing

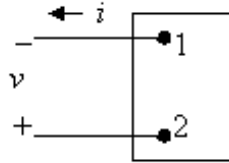

P 1.14 Assume we are standing at box A looking toward box B. Use the passive sign convention to get $p = vi$, since the current i is flowing into the $+$ terminal of the voltage v . Now we just substitute the values for v and i into the equation for power. Remember that if the power is positive, B is absorbing power, so the power must be flowing from A to B. If the power is negative, B is generating power so the power must be flowing from B to A.

$$\text{[a]} \quad p = (30)(6) = 180 \text{ W} \quad 180 \text{ W from A to B}$$

$$\text{[b]} \quad p = (-20)(-8) = 160 \text{ W} \quad 160 \text{ W from A to B}$$

$$\text{[c]} \quad p = (-60)(4) = -240 \text{ W} \quad 240 \text{ W from B to A}$$

$$\text{[d]} \quad p = (40)(-9) = -360 \text{ W} \quad 360 \text{ W from B to A}$$

P 1.15 [a] In Car A, the current i is in the direction of the voltage drop across the 12 V battery (the current i flows into the $+$ terminal of the battery of Car A). Therefore using the passive sign convention,
 $p = vi = (30)(12) = 360 \text{ W}$.
 Since the power is positive, the battery in Car A is absorbing power, so Car A must have the "dead" battery.

$$\text{[b]} \quad w(t) = \int_0^t p \, dx; \quad 1 \text{ min} = 60 \text{ s}$$

$$w(60) = \int_0^{60} 360 \, dx$$

$$w = 360(60 - 0) = 360(60) = 21,600 \text{ J} = 21.6 \text{ kJ}$$

$$\text{P 1.16} \quad p = vi; \quad w = \int_0^t p \, dx$$

Since the energy is the area under the power vs. time plot, let us plot p vs. t .

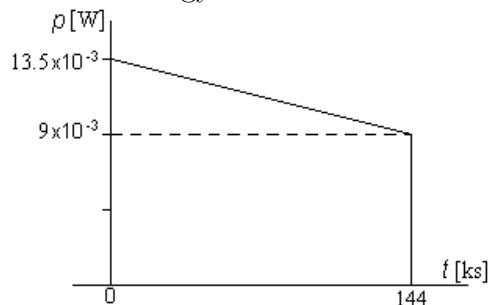

Note that in constructing the plot above, we used the fact that 40 hr
= 144,000 s = 144 ks

$$p(0) = (1.5)(9 \times 10^{-3}) = 13.5 \times 10^{-3} \text{ W}$$

$$p(144 \text{ ks}) = (1)(9 \times 10^{-3}) = 9 \times 10^{-3} \text{ W}$$

$$w = (9 \times 10^{-3})(144 \times 10^3) + \frac{1}{2}(13.5 \times 10^{-3} - 9 \times 10^{-3})(144 \times 10^3) = 1620 \text{ J}$$

$$\text{P 1.17 } p = (12)(100 \times 10^{-3}) = 1.2 \text{ W}; \quad 4 \text{ hr} \cdot \frac{3600 \text{ s}}{1 \text{ hr}} = 14,400 \text{ s}$$

$$w(t) = \int_0^t p \, dt \quad w(14,400) = \int_0^{14,400} 1.2 \, dt = 1.2(14,400) = 17.28 \text{ kJ}$$

$$\text{P 1.18 [a] } p = vi = (15e^{-250t})(0.04e^{-250t}) = 0.6e^{-500t} \text{ W}$$

$$p(0.01) = 0.6e^{-500(0.01)} = 0.6e^{-5} = 0.00404 = 4.04 \text{ mW}$$

$$\begin{aligned} \text{[b] } w_{\text{total}} &= \int_0^{\infty} p(x) \, dx = \int_0^{\infty} 0.6e^{-500x} \, dx = \left. \frac{0.6}{-500} e^{-500x} \right|_0^{\infty} \\ &= -0.0012(e^{-\infty} - e^0) = 0.0012 = 1.2 \text{ mJ} \end{aligned}$$

$$\text{P 1.19 [a] } p = vi = (0.05e^{-1000t})(75 - 75e^{-1000t}) = (3.75e^{-1000t} - 3.75e^{-2000t}) \text{ W}$$

$$\frac{dp}{dt} = -3750e^{-1000t} + 7500e^{-2000t} = 0 \quad \text{so} \quad 2e^{-2000t} = e^{-1000t}$$

$$2 = e^{1000t} \quad \text{so} \quad \ln 2 = 1000t \quad \text{thus} \quad p \text{ is maximum at } t = 693.15 \mu\text{s}$$

$$p_{\text{max}} = p(693.15 \mu\text{s}) = 937.5 \text{ mW}$$

$$\begin{aligned} \text{[b] } w &= \int_0^{\infty} [3.75e^{-1000t} - 3.75e^{-2000t}] \, dt = \left[\frac{3.75}{-1000} e^{-1000t} - \frac{3.75}{-2000} e^{-2000t} \right]_0^{\infty} \\ &= \frac{3.75}{1000} - \frac{3.75}{2000} = 1.875 \text{ mJ} \end{aligned}$$

$$\text{P 1.20 [a] } p = vi = 0.25e^{-3200t} - 0.5e^{-2000t} + 0.25e^{-800t}$$

$$p(625 \mu\text{s}) = 42.2 \text{ mW}$$

$$\begin{aligned} \text{[b] } w(t) &= \int_0^t (0.25e^{-3200t} - 0.5e^{-2000t} + 0.25e^{-800t}) \\ &= 140.625 - 78.125e^{-3200t} + 250e^{-2000t} - 312.5e^{-800t} \mu\text{J} \end{aligned}$$

$$w(625 \mu\text{s}) = 12.14 \mu\text{J}$$

$$\text{[c] } w_{\text{total}} = 140.625 \mu\text{J}$$

$$\begin{aligned}
 \text{P 1.21 [a]} \quad p &= vi \\
 &= [(1500t + 1)e^{-750t}](0.04e^{-750t}) \\
 &= (60t + 0.04)e^{-1500t} \\
 \frac{dp}{dt} &= 60e^{-1500t} - 1500e^{-1500t}(60t + 0.04) \\
 &= -90,000te^{-1500t}
 \end{aligned}$$

Therefore, $\frac{dp}{dt} = 0$ when $t = 0$
 so p_{\max} occurs at $t = 0$.

$$\begin{aligned}
 \text{[b]} \quad p_{\max} &= [(60)(0) + 0.04]e^0 = 0.04 \\
 &= 40 \text{ mW}
 \end{aligned}$$

$$\begin{aligned}
 \text{[c]} \quad w &= \int_0^t p dx \\
 w &= \int_0^t 60xe^{-1500x} dx + \int_0^t 0.04e^{-1500x} dx \\
 &= \frac{60e^{-1500x}}{(-1500)^2}(-1500x - 1) \Big|_0^t + 0.04 \frac{e^{-1500x}}{-1500} \Big|_0^t
 \end{aligned}$$

When $t = \infty$ all the upper limits evaluate to zero, hence

$$w = \frac{60}{225 \times 10^4} + \frac{0.04}{1500} = 53.33 \mu\text{J}.$$

$$\begin{aligned}
 \text{P 1.22 [a]} \quad p &= vi \\
 &= [(3200t + 3.2)e^{-1000t}][(160t + 0.16)e^{-1000t}] \\
 &= e^{-2000t}[512,000t^2 + 1024t + 0.512] \\
 \frac{dp}{dt} &= e^{-2000t}[1,024,000t + 1024] - 2000e^{-2000t}[512,000t^2 + 1024t + 0.512] \\
 &= -e^{-2000t}[1024 \times 10^6 t^2 + 1,024,000t]
 \end{aligned}$$

Therefore, $\frac{dp}{dt} = 0$ when $t = 0$
 so p_{\max} occurs at $t = 0$.

$$\begin{aligned}
 \text{[b]} \quad p_{\max} &= e^{-0}[0 + 0 + 0.512] \\
 &= 512 \text{ mW}
 \end{aligned}$$

$$\begin{aligned}
 \text{[c]} \quad w &= \int_0^t p dx \\
 w &= \int_0^t 512,000x^2 e^{-2000x} dx + \int_0^t 1024xe^{-2000x} dx + \int_0^t 0.512e^{-2000x} dx \\
 &= \frac{512,000e^{-2000x}}{-8 \times 10^9} [4 \times 10^6 x^2 + 4000x + 2] \Big|_0^t + \\
 &\quad \frac{1024e^{-2000x}}{4 \times 10^6} (-2000x - 1) \Big|_0^t + \frac{0.512e^{-2000x}}{-2000} \Big|_0^t
 \end{aligned}$$

When $t \rightarrow \infty$ all the upper limits evaluate to zero, hence

$$w = \frac{(512,000)(2)}{8 \times 10^9} + \frac{1024}{4 \times 10^6} + \frac{0.512}{2000}$$

$$w = 128 \times 10^{-6} + 256 \times 10^{-6} + 256 \times 10^{-6} = 640 \mu\text{J}.$$

- P 1.23 [a] We can find the time at which the power is a maximum by writing an expression for $p(t) = v(t)i(t)$, taking the first derivative of $p(t)$ and setting it to zero, then solving for t . The calculations are shown below:

$$p = 0 \quad t < 0, \quad p = 0 \quad t > 40 \text{ s}$$

$$p = vi = t(1 - 0.025t)(4 - 0.2t) = 4t - 0.3t^2 + 0.005t^3 \text{ W} \quad 0 \leq t \leq 40 \text{ s}$$

$$\frac{dp}{dt} = 4 - 0.6t + 0.015t^2 = 0.015(t^2 - 40t + 266.67)$$

$$\frac{dp}{dt} = 0 \quad \text{when } t^2 - 40t + 266.67 = 0$$

$$t_1 = 8.453 \text{ s}; \quad t_2 = 31.547 \text{ s}$$

(using the polynomial solver on your calculator)

$$p(t_1) = 4(8.453) - 0.3(8.453)^2 + 0.005(8.453)^3 = 15.396 \text{ W}$$

$$p(t_2) = 4(31.547) - 0.3(31.547)^2 + 0.005(31.547)^3 = -15.396 \text{ W}$$

Therefore, maximum power is being delivered at $t = 8.453 \text{ s}$.

- [b] The maximum power was calculated in part (a) to determine the time at which the power is maximum: $p_{\max} = 15.396 \text{ W}$ (delivered)
- [c] As we saw in part (a), the other “maximum” power is actually a minimum, or the maximum negative power. As we calculated in part (a), maximum power is being extracted at $t = 31.547 \text{ s}$.
- [d] This maximum extracted power was calculated in part (a) to determine the time at which power is maximum: $p_{\max} = 15.396 \text{ W}$ (extracted)

$$[e] w = \int_0^t p dx = \int_0^t (4x - 0.3x^2 + 0.005x^3) dx = 2t^2 - 0.1t^3 + 0.00125t^4$$

$$w(0) = 0 \text{ J} \qquad w(30) = 112.5 \text{ J}$$

$$w(10) = 112.5 \text{ J} \qquad w(40) = 0 \text{ J}$$

$$w(20) = 200 \text{ J}$$

To give you a feel for the quantities of voltage, current, power, and energy and their relationships among one another, they are plotted below:

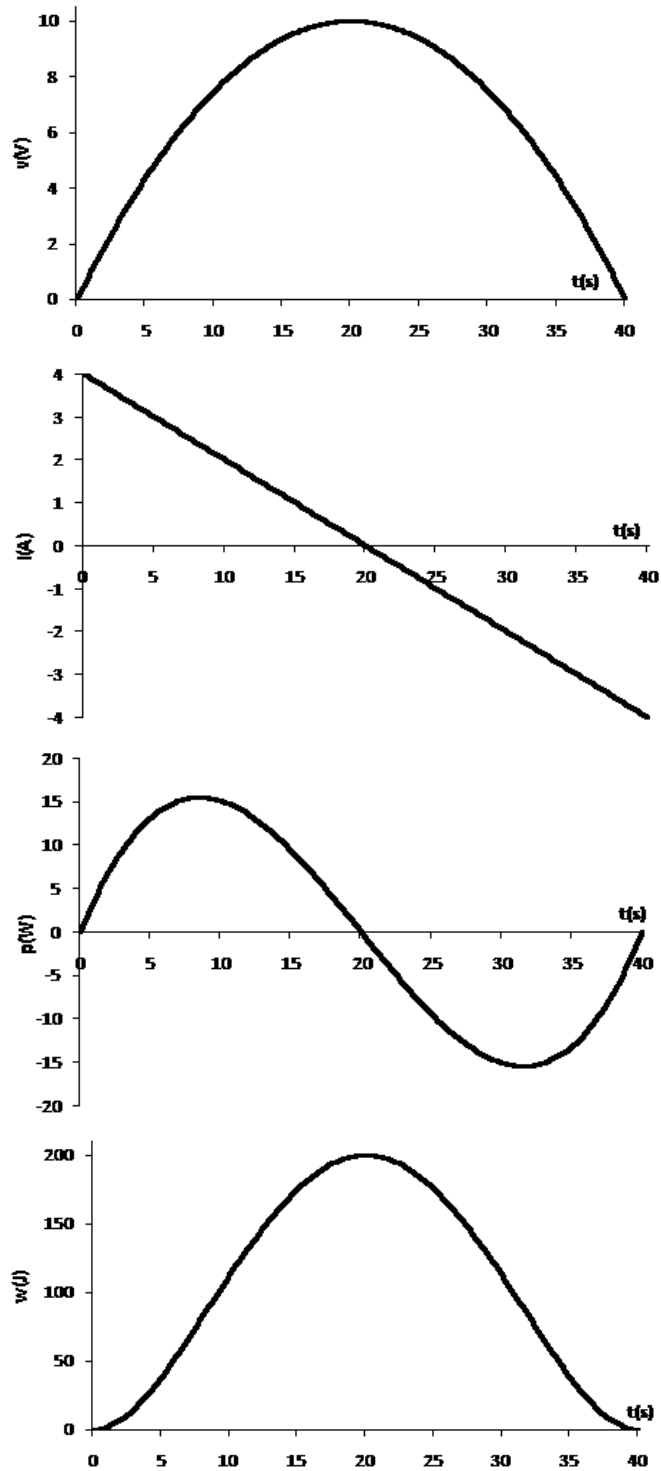

P 1.24 [a] $v(10 \text{ ms}) = 400e^{-1} \sin 2 = 133.8 \text{ V}$
 $i(10 \text{ ms}) = 5e^{-1} \sin 2 = 1.67 \text{ A}$
 $p(10 \text{ ms}) = vi = 223.80 \text{ W}$

$$\begin{aligned}
\text{[b]} \quad p &= vi = 2000e^{-200t} \sin^2 200t \\
&= 2000e^{-200t} \left[\frac{1}{2} - \frac{1}{2} \cos 400t \right] \\
&= 1000e^{-200t} - 1000e^{-200t} \cos 400t \\
w &= \int_0^\infty 1000e^{-200t} dt - \int_0^\infty 1000e^{-200t} \cos 400t dt \\
&= 1000 \left. \frac{e^{-200t}}{-200} \right|_0^\infty \\
&\quad - 1000 \left\{ \frac{e^{-200t}}{(200)^2 + (400)^2} [-200 \cos 400t + 400 \sin 400t] \right\} \Big|_0^\infty \\
&= 5 - 1000 \left[\frac{200}{4 \times 10^4 + 16 \times 10^4} \right] = 5 - 1 \\
w &= 4 \text{ J}
\end{aligned}$$

P 1.25 [a] $p = vi = 2000 \cos(800\pi t) \sin(800\pi t) = 1000 \sin(1600\pi t)$ W

Therefore, $p_{\max} = 1000$ W

[b] $p_{\max}(\text{extracting}) = 1000$ W

[c]
$$\begin{aligned}
p_{\text{avg}} &= \frac{1}{2.5 \times 10^{-3}} \int_0^{2.5 \times 10^{-3}} 1000 \sin(1600\pi t) dt \\
&= 4 \times 10^5 \left[\frac{-\cos 1600\pi t}{1600\pi} \right]_0^{2.5 \times 10^{-3}} = \frac{250}{\pi} [1 - \cos 4\pi] = 0
\end{aligned}$$

[d]

$$\begin{aligned}
p_{\text{avg}} &= \frac{1}{15.625 \times 10^{-3}} \int_0^{15.625 \times 10^{-3}} 1000 \sin(1600\pi t) dt \\
&= 64 \times 10^3 \left[\frac{-\cos 1600\pi t}{1600\pi} \right]_0^{15.625 \times 10^{-3}} = \frac{40}{\pi} [1 - \cos 25\pi] = 25.46 \text{ W}
\end{aligned}$$

P 1.26 [a] $q =$ area under i vs. t plot

$$\begin{aligned}
&= \frac{1}{2}(8)(12,000) + (16)(12,000) + \frac{1}{2}(16)(4000) \\
&= 48,000 + 192,000 + 32,000 = 272,000 \text{ C}
\end{aligned}$$

[b] $w = \int p dt = \int vi dt$

$$v = 250 \times 10^{-6}t + 8 \quad 0 \leq t \leq 16 \text{ ks}$$

$$0 \leq t \leq 12,000\text{s:}$$

$$i = 24 - 666.67 \times 10^{-6}t$$

$$p = 192 + 666.67 \times 10^{-6}t - 166.67 \times 10^{-9}t^2$$

$$\begin{aligned}
w_1 &= \int_0^{12,000} (192 + 666.67 \times 10^{-6}t - 166.67 \times 10^{-9}t^2) dt \\
&= (2304 + 48 - 96)10^3 = 2256 \text{ kJ}
\end{aligned}$$

12,000 s $\leq t \leq$ 16,000 s:

$$i = 64 - 4 \times 10^{-3}t$$

$$p = 512 - 16 \times 10^{-3}t - 10^{-6}t^2$$

$$\begin{aligned} w_2 &= \int_{12,000}^{16,000} (512 - 16 \times 10^{-3}t - 10^{-6}t^2) dt \\ &= (2048 - 896 - 789.33)10^3 = 362.667 \text{ kJ} \end{aligned}$$

$$w_T = w_1 + w_2 = 2256 + 362.667 = 2618.667 \text{ kJ}$$

P 1.27 [a] 0 s $\leq t <$ 10 ms:

$$v = 8 \text{ V}; \quad i = 25t \text{ A}; \quad p = 200t \text{ W}$$

10 ms $< t \leq$ 30 ms:

$$v = -8 \text{ V}; \quad i = 0.5 - 25t \text{ A}; \quad p = 200t - 4 \text{ W}$$

30 ms $\leq t <$ 40 ms:

$$v = 0 \text{ V}; \quad i = -250 \text{ mA}; \quad p = 0 \text{ W}$$

40 ms $< t \leq$ 60 ms:

$$v = 8 \text{ V}; \quad i = 25t - 1.25 \text{ A}; \quad p = 200t - 10 \text{ W}$$

$t >$ 60 ms:

$$v = 0 \text{ V}; \quad i = 250 \text{ mA}; \quad p = 0 \text{ W}$$

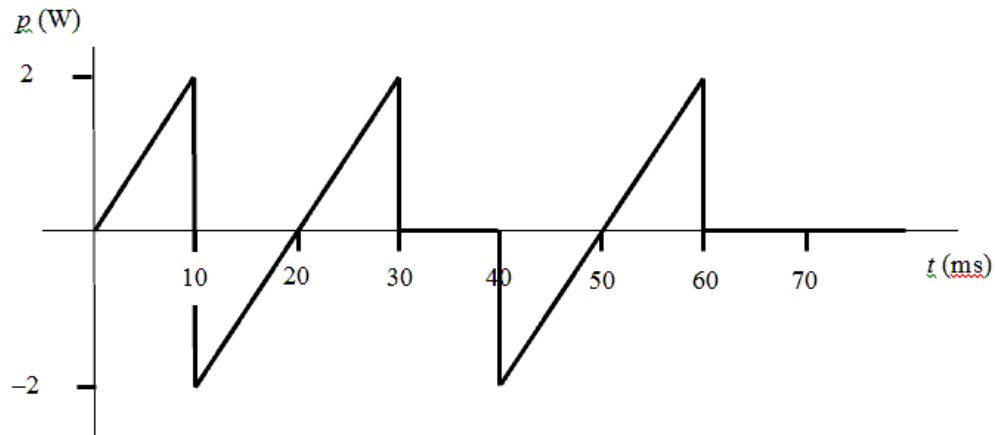

[b] Calculate the area under the curve from zero to the desired time:

$$w(0.01) = \frac{1}{2}(2)(0.01) = 10 \text{ mJ}$$

$$w(0.03) = w(0.01) - \frac{1}{2}(2)(0.01) + \frac{1}{2}(2)(0.01) = 10 \text{ mJ}$$

$$w(0.08) = w(0.03) - \frac{1}{2}(2)(0.01) + \frac{1}{2}(2)(0.01) = 10 \text{ mJ}$$

P 1.28 [a]

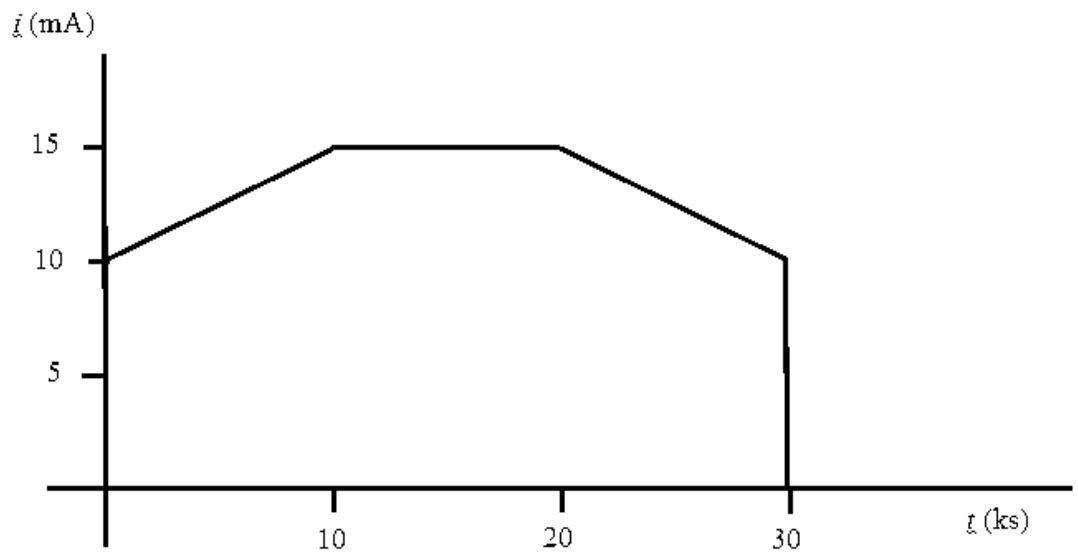

$$\begin{aligned}
 \text{[b]} \quad i(t) &= 10 + 0.5 \times 10^{-3}t \text{ mA}, & 0 \leq t \leq 10 \text{ ks} \\
 i(t) &= 15 \text{ mA}, & 10 \text{ ks} \leq t \leq 20 \text{ ks} \\
 i(t) &= 25 - 0.5 \times 10^{-3}t \text{ mA}, & 20 \text{ ks} \leq t \leq 30 \text{ ks} \\
 i(t) &= 0, & t > 30 \text{ ks}
 \end{aligned}$$

$$p = vi = 120i \text{ so}$$

$$\begin{aligned}
 p(t) &= 1200 + 0.06t \text{ mW}, & 0 \leq t \leq 10 \text{ ks} \\
 p(t) &= 1800 \text{ mW}, & 10 \text{ ks} \leq t \leq 20 \text{ ks} \\
 p(t) &= 3000 - 0.06t \text{ mW}, & 20 \text{ ks} \leq t \leq 30 \text{ ks} \\
 p(t) &= 0, & t > 30 \text{ ks}
 \end{aligned}$$

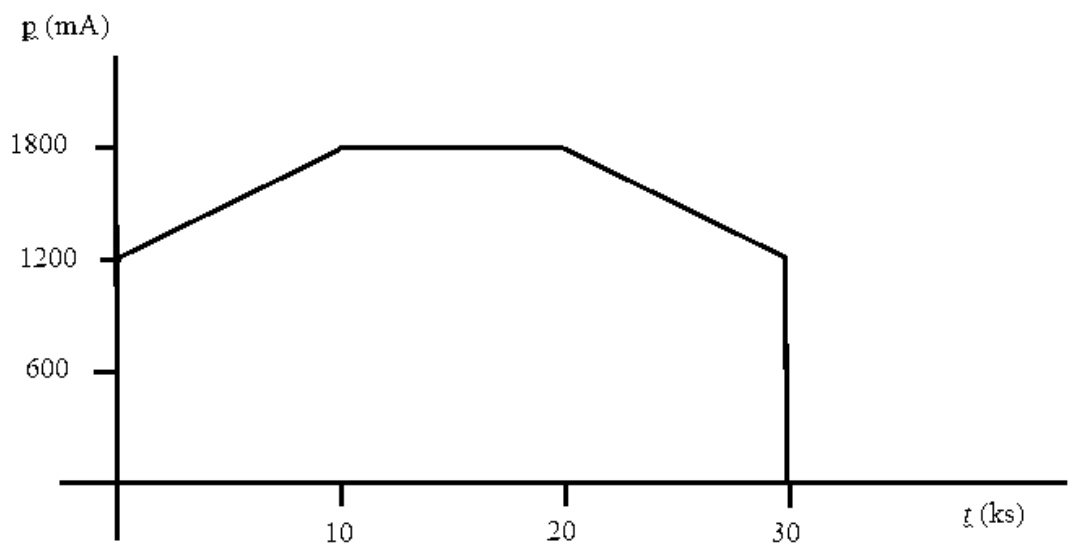

[c] To find the energy, calculate the area under the plot of the power:

$$w(10 \text{ ks}) = \frac{1}{2}(0.6)(10,000) + (1.2)(10,000) = 15 \text{ kJ}$$

$$w(20 \text{ ks}) = w(10 \text{ ks}) + (1.8)(10,000) = 33 \text{ kJ}$$

$$w(30 \text{ ks}) = w(20 \text{ ks}) + \frac{1}{2}(0.6)(10,000) + (1.2)(10,000) = 48 \text{ kJ}$$

P 1.29 We use the passive sign convention to determine whether the power equation is $p = vi$ or $p = -vi$ and substitute into the power equation the values for v and i , as shown below:

$$p_a = -v_a i_a = -(40)(-4 \times 10^{-3}) = 160 \text{ mW}$$

$$p_b = v_b i_b = (-24)(-4 \times 10^{-3}) = 96 \text{ mW}$$

$$p_c = -v_c i_c = -(-16)(4 \times 10^{-3}) = 64 \text{ mW}$$

$$p_d = -v_d i_d = -(-80)(-1.5 \times 10^{-3}) = -120 \text{ mW}$$

$$p_e = v_e i_e = (40)(2.5 \times 10^{-3}) = 100 \text{ mW}$$

$$p_f = v_f i_f = (120)(-2.5 \times 10^{-3}) = -300 \text{ mW}$$

Remember that if the power is positive, the circuit element is absorbing power, whereas if the power is negative, the circuit element is developing power. We can add the positive powers together and the negative powers together — if the power balances, these power sums should be equal:

$$\sum P_{\text{dev}} = 120 + 300 = 420 \text{ mW};$$

$$\sum P_{\text{abs}} = 160 + 96 + 64 + 100 = 420 \text{ mW}$$

Thus, the power balances and the total power absorbed in the circuit is 420 mW.

P 1.30 $p_a = -v_a i_a = -(-3000)(-250 \times 10^{-6}) = -0.75 \text{ W}$

$$p_b = -v_b i_b = -(4000)(-400 \times 10^{-6}) = 1.6 \text{ W}$$

$$p_c = -v_c i_c = -(1000)(400 \times 10^{-6}) = -0.4 \text{ W}$$

$$p_d = v_d i_d = (1000)(150 \times 10^{-6}) = 0.15 \text{ W}$$

$$p_e = v_e i_e = (-4000)(200 \times 10^{-6}) = -0.8 \text{ W}$$

$$p_f = v_f i_f = (4000)(50 \times 10^{-6}) = 0.2 \text{ W}$$

Therefore,

$$\sum P_{\text{abs}} = 1.6 + 0.15 + 0.2 = 1.95 \text{ W}$$

$$\sum P_{\text{del}} = 0.75 + 0.4 + 0.8 = 1.95 \text{ W} = \sum P_{\text{abs}}$$

Thus, the interconnection does satisfy the power check.

P 1.31 [a] From the diagram and the table we have

$$p_a = -v_a i_a = -(46.16)(6) = -276.96 \text{ W}$$

$$p_b = v_b i_b = (14.16)(4.72) = 66.8352 \text{ W}$$

$$p_c = v_c i_c = (-32)(-6.4) = 204.8 \text{ W}$$

$$p_d = -v_d i_d = -(22)(1.28) = -28.16 \text{ W}$$

$$p_e = v_e i_e = (-33.6)(-1.68) = 56.448 \text{ W}$$

$$p_f = v_f i_f = (66)(0.4) = 26.4 \text{ W}$$

$$p_g = v_g i_g = (2.56)(1.28) = 3.2768 \text{ W}$$

$$p_h = -v_h i_h = -(-0.4)(0.4) = 0.16 \text{ W}$$

$$\sum P_{\text{del}} = 276.96 + 28.16 = 305.12 \text{ W}$$

$$\sum P_{\text{abs}} = 66.8352 + 204.8 + 56.448 + 26.4 + 3.2768 + 0.16 = 357.92 \text{ W}$$

Therefore, $\sum P_{\text{del}} \neq \sum P_{\text{abs}}$ and the subordinate engineer is correct.

[b] The difference between the power delivered to the circuit and the power absorbed by the circuit is

$$-305.12 + 357.92 = 52.8 \text{ W}$$

One-half of this difference is 26.4 W, so it is likely that p_f is in error. Either the voltage or the current probably has the wrong sign. (In Chapter 2, we will discover that using KCL at the node connecting components f and h, the current i_f should be -0.4 A, not 0.4 A!) If the sign of p_f is changed from negative to positive, we can recalculate the power delivered and the power absorbed as follows:

$$\sum P_{\text{del}} = 276.96 + 28.16 + 26.4 = 331.52 \text{ W}$$

$$\sum P_{\text{abs}} = 66.8352 + 204.8 + 56.448 + 3.2768 + 0.16 = 331.52 \text{ W}$$

Now the power delivered equals the power absorbed and the power balances for the circuit.

P 1.32 [a] Remember that if the circuit element is absorbing power, the power is positive, whereas if the circuit element is supplying power, the power is negative. We can add the positive powers together and the negative powers together — if the power balances, these power sums should be equal: $\sum P_{\text{sup}} = 600 + 50 + 600 + 1250 = 2500 \text{ W}$;

$$\sum P_{\text{abs}} = 400 + 100 + 2000 = 2500 \text{ W}$$

Thus, the power balances.

[b] The current can be calculated using $i = p/v$ or $i = -p/v$, with proper application of the passive sign convention:

$$i_a = -p_a/v_a = -(-600)/(400) = 1.5 \text{ A}$$

$$i_b = p_b/v_b = (-50)/(-100) = 0.5 \text{ A}$$

$$i_c = p_c/v_c = (400)/(200) = 2.0 \text{ A}$$

$$i_d = p_d/v_d = (-600)/(300) = -2.0 \text{ A}$$

$$i_e = p_e/v_e = (100)/(-200) = -0.5 \text{ A}$$

$$i_f = -p_f/v_f = -(2000)/(500) = -4.0 \text{ A}$$

$$i_g = p_g/v_g = (-1250)/(-500) = 2.5 \text{ A}$$

P 1.33 [a] If the power balances, the sum of the power values should be zero:

$$p_{\text{total}} = 0.175 + 0.375 + 0.150 - 0.320 + 0.160 + 0.120 - 0.660 = 0$$

Thus, the power balances.

[b] When the power is positive, the element is absorbing power. Since elements a, b, c, e, and f have positive power, these elements are absorbing power.

[c] The voltage can be calculated using $v = p/i$ or $v = -p/i$, with proper application of the passive sign convention:

$$v_a = p_a/i_a = (0.175)/(0.025) = 7 \text{ V}$$

$$v_b = p_b/i_b = (0.375)/(0.075) = 5 \text{ V}$$

$$v_c = -p_c/i_c = -(0.150)/(-0.05) = 3 \text{ V}$$

$$v_d = p_d/i_d = (-0.320)/(0.04) = -8 \text{ V}$$

$$v_e = -p_e/i_e = -(0.160)/(0.02) = -8 \text{ V}$$

$$v_f = p_f/i_f = (0.120)/(-0.03) = -4 \text{ V}$$

$$v_g = p_g/i_g = (-0.66)/(0.055) = -12 \text{ V}$$

P 1.34 $p_a = v_a i_a = (120)(-10) = -1200 \text{ W}$

$$p_b = -v_b i_b = -(120)(9) = -1080 \text{ W}$$

$$p_c = v_c i_c = (10)(10) = 100 \text{ W}$$

$$p_d = -v_d i_d = -(10)(-1) = 10 \text{ W}$$

$$p_e = v_e i_e = (-10)(-9) = 90 \text{ W}$$

$$p_f = -v_f i_f = -(-100)(5) = 500 \text{ W}$$

$$p_g = v_g i_g = (120)(4) = 480 \text{ W}$$

$$p_h = v_h i_h = (-220)(-5) = 1100 \text{ W}$$

$$\sum P_{\text{del}} = 1200 + 1080 = 2280 \text{ W}$$

$$\sum P_{\text{abs}} = 100 + 10 + 90 + 500 + 480 + 1100 = 2280 \text{ W}$$

Therefore, $\sum P_{\text{del}} = \sum P_{\text{abs}} = 2280 \text{ W}$

Thus, the interconnection now satisfies the power check.

P 1.35 [a] The revised circuit model is shown below:

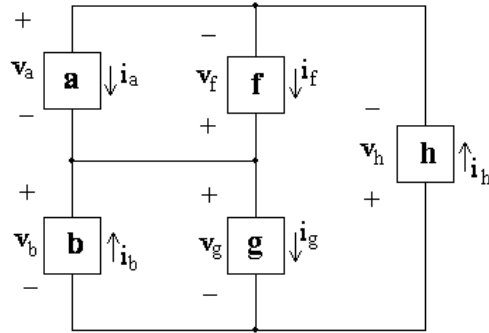

[b] The expression for the total power in this circuit is

$$\begin{aligned} v_a i_a - v_b i_b - v_f i_f + v_g i_g + v_h i_h \\ = (120)(-10) - (120)(10) - (-120)(3) + 120i_g + (-240)(-7) = 0 \end{aligned}$$

Therefore,

$$120i_g = 1200 + 1200 - 360 - 1680 = 360$$

so

$$i_g = \frac{360}{120} = 3 \text{ A}$$

Thus, if the power in the modified circuit is balanced the current in component g is 3 A.